



Research article

Fixed point results in C^* -algebra-valued bipolar metric spaces with an application

Gunaseelan Mani¹, Arul Joseph Gnanaprakasam², Hüseyin Işık^{3,*} and Fahd Jarad^{4,5,*}

¹ Department of Mathematics, Saveetha School of Engineering, Saveetha Institute of Medical and Technical Sciences, Chennai 602105, Tamil Nadu, India

² Department of Mathematics, College of Engineering and Technology, Faculty of Engineering and Technology, SRM Institute of Science and Technology, SRM Nagar, Kattankulathur 603203, Kanchipuram, Chennai, Tamil Nadu, India

³ Department of Engineering Science, Bandırma Onyedi Eylül University, Bandırma 10200, Balıkesir, Turkey

⁴ Department of Mathematics, Cankaya University, 06790 Etimesgut, Ankara, Turkey

⁵ Department of Medical Research, China Medical University Hospital, China Medical University, Taichung 40402, Taiwan

* **Correspondence:** Email: isikhuseyin76@gmail.com, fahd@cankaya.edu.tr.

Abstract: In this work, we prove existence and uniqueness fixed point theorems under Banach and Kannan type contractions on C^* -algebra-valued bipolar metric spaces. To strengthen our main results, an appropriate example and an effective application are presented.

Keywords: C^* -algebra; C^* -algebra-valued bipolar metric space; fixed point

Mathematics Subject Classification: 46L05, 47H10, 54H25, 54C30

1. Introduction

Fréchet [1] introduced the notion of metric spaces in 1906. Since then, metric spaces have been widely generalised by removing or relaxing certain axioms, modifying the metric function, or abstracting the concept. These structures have been more prominent in fixed point investigations in recent years, and numerous useful findings have been made in this area [1–10]. One of the most recent generalizations is that of a bipolar metric space, introduced by Mutlu and Gürdal [11], the motivation being that in many real-life applications, distances arise between elements of two different sets, rather than between points of a unique set. Hence, bipolar metrics came to formalize these types

of distances. Some basic examples are distance between lines and points in an Euclidean space, distance between points and sets in a metric spaces, affinity between a class of students and a set of activities, lifetime mean distances between people and places, and many more. Gürdal, Mutlu and Özkan [12] introduced the notion of α - ψ contractive type covariant and contravariant mappings in the bipolar metric spaces, which provides a framework to study distances between dissimilar objects. Kishore, Agarwal, Rao and Rao [13] proved existence and uniqueness of the solution for three self mappings in a complete bipolar metric space under a new Caristi type contraction. Kishore, Prasad, Rao and Baghavan [14] proved existence of common coupled fixed point results for two covariant mappings in bipolar metric spaces. Kishore, Rao, Sombabu and Rao [15] introduced the concept of multivalued contraction mappings in partially ordered bipolar metric spaces and proved existence of unique coupled fixed point results for multivalued contractive mapping by using mixed monotone property in partially ordered bipolar metric spaces. Rao, Kishore and Kumar [16] proved existence of common coupled fixed point results of two covariant mappings in a complete bipolar metric spaces under Geraghty type contraction by using weakly compatible mappings. Kishore, Rao, Işık, Rao and Sombabu [17] proved existence and uniqueness of common coupled fixed point results for three covariant mappings in bipolar metric spaces. Mutlu, Özkan and Gürdal [18] introduced the concepts of (ϵ, λ) -uniformly locally contractive and weakly contractive mappings, which are generalizations of Banach contraction mapping and proved fixed point theorems on bipolar metric spaces. Gaba, Aphane and Aydi [19] introduced the concept of (α, BK) -contractions and proved the existence of fixed points for contravariant mappings on bipolar metric spaces. Roy, Saha, George, Gurand and Mitrović [20] introduced the concept of bipolar p -metric space and proved fixed point theorems on bipolar p -metric space.

Definition 1.1. [11] Let Φ and Ψ be two non-void subsets of a set V and $\varphi : \Phi \times \Psi \rightarrow \mathbb{R}^+$ be a function such that

- (a) $\varphi(\eta, \sigma) = 0$ iff $\eta = \sigma$;
- (b) $\varphi(\eta, \sigma) = \varphi(\sigma, \eta)$, for all $\eta, \sigma \in \Phi \cap \Psi$;
- (c) $\varphi(\eta, \sigma) \leq \varphi(\eta, \sigma_1) + \varphi(\eta_1, \sigma_1) + \varphi(\eta_1, \sigma)$, for all $\eta, \eta_1 \in \Phi$ and $\sigma, \sigma_1 \in \Psi$.

The triple (Φ, Ψ, φ) is called a bipolar metric space.

In 2014, Ma et al. [21] proved fixed point theorems on C^* -algebra-valued metric spaces. Batul and Kamran [22] introduced the notion of continuity in the context of C^* -valued metric spaces and proved fixed point theorems on C^* -algebra-valued metric spaces. Recently, Gunaseelan, Arul Joseph, Ul Haq, Baloch and Jarad [23], introduced the notion of a C^* -algebra-valued bipolar metric space and proved coupled fixed theorems. In this paper, we prove fixed point theorems on C^* -algebra-valued bipolar metric space. The details on C^* -algebra-valued are available in [24–26].

A complex algebra \mathcal{H} , together with a conjugate linear involution map $p \mapsto p^*$, is called a \star -algebra if $(pq)^* = q^*p^*$ and $(p^*)^* = p$ for all $p, q \in \mathcal{H}$. Moreover, the pair (\mathcal{H}, \star) is called a unital \star -algebra if \mathcal{H} contains an identity element $1_{\mathcal{H}}$. By a Banach \star -algebra we mean a complete normed unital \star -algebra (\mathcal{H}, \star) such that the norm on \mathcal{H} is submultiplicative and satisfies $\|p^*\| = \|p\|$ for all $p \in \mathcal{H}$. Further, if for all $p \in \mathcal{H}$, we have $\|p^*p\| = \|p\|^2$ in a Banach \star -algebra (\mathcal{H}, \star) , then \mathcal{H} is known as a C^* -algebra. A positive element of \mathcal{H} is an element $p \in \mathcal{H}$ such that $p = p^*$ and its spectrum

$\sigma(p) \subset \mathbb{R}^+$, where $\sigma(p) = \{\lambda \in \mathbb{C} : \lambda 1_{\mathcal{H}} - p \text{ is non invertible}\}$. The set of all positive elements will be denoted by \mathcal{H}_+ . Such elements allow us to define a partial ordering \geq on the elements of \mathcal{H} . That is,

$$q \geq p \text{ if and only if } q - p \in \mathcal{H}_+.$$

If $p \in \mathcal{H}$ is positive, then we write $p \geq 0_{\mathcal{H}}$, where $0_{\mathcal{H}}$ is the zero element of \mathcal{H} . Each positive element p of a C^* -algebra \mathcal{H} has a unique positive square root denoted by $p^{\frac{1}{2}}$ in \mathcal{H} . From now on, by \mathcal{H} we mean a unital C^* -algebra with identity element $1_{\mathcal{H}}$. Further, $\mathcal{H}_+ = \{p \in \mathcal{H} : p \geq 0_{\mathcal{H}}\}$ and $(p^*p)^{1/2} = \|p\|$.

In this article, we prove existence and uniqueness fixed point theorems on C^* -algebra-valued bipolar metric spaces. The main objectives of this article are as follows:

- To prove several fixed point theorems for contraction mappings.
- To find the existence and uniqueness of the solution of an integral equation.

2. Preliminaries

In 2022, Gunaseelan, Arul Joseph, Ul Haq, Baloch and Jarad [23], introduced the notion of a bipolar metric space in the setting of C^* -algebra and proved coupled fixed point theorem as follows.

Definition 2.1. [23] Let \mathcal{H} be a C^* -algebra, Φ, Ψ be two non-void subset of a set V , and $\varphi : \Phi \times \Psi \rightarrow \mathcal{H}_+$ be a mapping such that

- (a) $\varphi(\eta, \sigma) = 0_{\mathcal{H}}$ iff $\eta = \sigma$;
- (b) $\varphi(\eta, \sigma) = \varphi(\sigma, \eta)$, for all $\eta, \sigma \in \Phi \cap \Psi$;
- (c) $\varphi(\eta, \sigma) \leq \varphi(\eta, \sigma_1) + \varphi(\eta_1, \sigma_1) + \varphi(\eta_1, \sigma)$, for all $\eta, \eta_1 \in \Phi$ and $\sigma, \sigma_1 \in \Psi$.

The 4-tuple $(\Phi, \Psi, \mathcal{H}, \varphi)$ is called a C^* -algebra-valued bipolar metric space.

Example 2.2. Let $\Phi = [0, 1]$, $\Psi = [-1, 1]$, $\mathcal{H} = \mathbb{C}$ and $\varphi : \Phi \times \Psi \rightarrow \mathcal{H}_+$ be defined by

$$\varphi(\eta, \sigma) = |\eta - \sigma|$$

for all $\eta \in \Phi$ and $\sigma \in \Psi$. Then $(\Phi, \Psi, \mathcal{H}, \varphi)$ is a C^* -algebra-valued bipolar metric space.

Lemma 2.3. [25] Suppose that \mathcal{H} is a unital C^* -algebra with a unit I .

- (A1) For any $\eta \in \mathcal{H}_+$ we have $\eta \leq I$ iff $\|\eta\| \leq 1$.
- (A2) If $p \in \mathcal{H}_+$ with $\|p\| < \frac{1}{2}$, then $I - p$ is invertible and $\|p(I - p)^{-1}\| < 1$.
- (A3) If $p, q \in \mathcal{H}_+$ and $pq = qp$, then $pq \in \mathcal{H}_+$.
- (A4) By \mathcal{H}' we denote the set $\{p \in \mathcal{H} : pq = qp, \forall q \in \mathcal{H}\}$. Let $p \in \mathcal{H}'$, if $q, c \in \mathcal{H}$ with $q \geq c \geq 0_{\mathcal{H}}$, and $I - p \in \mathcal{H}'_+$ is an invertible operator, then

$$(I - p)^{-1}q \geq (I - p)^{-1}c.$$

Notice that in a C^* -algebra, if $p, q \in \mathcal{H}_+$, one cannot conclude that $pq \in \mathcal{H}_+$.

Definition 2.4. [23] Let $(\Phi_1, \Psi_1, \mathcal{H}, \varphi_1)$ and $(\Phi_2, \Psi_2, \mathcal{H}, \varphi_2)$ be C^* -algebra-valued bipolar metric spaces and take any mapping $\Gamma : \Phi_1 \cup \Psi_1 \rightarrow \Phi_2 \cup \Psi_2$.

(B1) If $\Gamma(\Phi_1) \subseteq \Phi_2$ and $\Gamma(\Psi_1) \subseteq \Psi_2$, then Γ is called a covariant map from $(\Phi_1, \Psi_1, \mathcal{H}, \varphi_1)$ to $(\Phi_2, \Psi_2, \mathcal{H}, \varphi_2)$ and this is written as $\Gamma : (\Phi_1, \Psi_1, \mathcal{H}, \varphi_1) \rightrightarrows (\Phi_2, \Psi_2, \mathcal{H}, \varphi_2)$.

(B2) If $\Gamma(\Phi_1) \subseteq \Psi_2$ and $\Gamma(\Psi_1) \subseteq \Phi_2$, then Γ is called a contravariant map from $(\Phi_1, \Psi_1, \mathcal{H}, \varphi_1)$ to $(\Phi_2, \Psi_2, \mathcal{H}, \varphi_2)$ and this is denoted as $\Gamma : (\Phi_1, \Psi_1, \mathcal{H}, \varphi_1) \leftrightsquigarrow (\Phi_2, \Psi_2, \mathcal{H}, \varphi_2)$.

Theorem 2.5. [23] Let $(\Phi, \Psi, \mathcal{H}, \varphi)$ be a complete C^* -algebra-valued bipolar metric space. Suppose $\Gamma : (\Phi^2, \Psi^2, \mathcal{H}, \varphi) \rightrightarrows (\Phi, \Psi, \mathcal{H}, \varphi)$ is a covariant mapping such that

$$\varphi(\Gamma(\eta, \sigma), \Gamma(u, v)) \leq \aleph^* \varphi(\eta, u) \aleph + \aleph^* \varphi(\sigma, v) \aleph \text{ for all } \eta, \sigma \in \Phi, u, v \in \Psi,$$

where $\aleph \in \mathcal{H}$ with $2\|\aleph\|^2 < 1$. Then the function $\Gamma : \Phi^2 \cup \Psi^2 \rightarrow \Phi \cup \Psi$ has a unique coupled fixed point.

Motivated by the above theorem, we prove fixed point theorems on C^* -algebra-valued bipolar metric space.

Definition 2.6. (C1) The mapping $\Gamma : (\Phi_1, \Psi_1, \mathcal{H}, \varphi_1) \rightrightarrows (\Phi_2, \Psi_2, \mathcal{H}, \varphi_2)$ is called left continuous at a point $\eta \in \Phi_1$ if for every sequence $\{\sigma_\alpha\} \subset \Psi_1$ with $\{\sigma_\alpha\} \rightarrow \eta$, we have $\{\Gamma(\sigma_\alpha)\} \rightarrow \Gamma\eta$ in $(\Phi_2, \Psi_2, \mathcal{H}, \varphi_2)$.

(C2) The mapping $\Gamma : (\Phi_1, \Psi_1, \mathcal{H}, \varphi_1) \rightrightarrows (\Phi_2, \Psi_2, \mathcal{H}, \varphi_2)$ is called right continuous at a point $\sigma \in \Psi_1$ if for every sequence $\{\eta_\alpha\} \subset \Phi_1$ with $\{\eta_\alpha\} \rightarrow \sigma$, we have $\{\Gamma(\eta_\alpha)\} \rightarrow \Gamma\sigma$ in $(\Phi_2, \Psi_2, \mathcal{H}, \varphi_2)$.

(C3) The mapping $\Gamma : (\Phi_1, \Psi_1, \mathcal{H}, \varphi_1) \rightrightarrows (\Phi_2, \Psi_2, \mathcal{H}, \varphi_2)$ is said to be continuous if it is left continuous at each point $\eta \in \Phi_1$ and right continuous at each point $\sigma \in \Psi_1$.

(C4) A contravariant mapping $\Gamma : (\Phi_1, \Psi_1, \mathcal{H}, \varphi_1) \leftrightsquigarrow (\Phi_2, \Psi_2, \mathcal{H}, \varphi_2)$ is continuous if and only if it is continuous as a covariant map $\Gamma : (\Phi_1, \Psi_1, \mathcal{H}, \varphi_1) \rightrightarrows (\Psi_2, \Phi_2, \mathcal{H}, \varphi_2)$.

This definition implies that a contravariant or a covariant map Γ , which is defined from $(\Phi_1, \Psi_1, \mathcal{H}, \varphi_1)$ to $(\Phi_2, \Psi_2, \mathcal{H}, \varphi_2)$, is continuous, iff $\{\eta_\alpha\} \rightarrow \sigma$ on $(\Phi_1, \Psi_1, \mathcal{H}, \varphi_1)$ implies $\{\Gamma(\eta_\alpha)\} \rightarrow \Gamma\sigma$ on $(\Phi_2, \Psi_2, \mathcal{H}, \varphi_2)$.

Definition 2.7. Let $(\Phi_1, \Psi_1, \mathcal{H}, \varphi_1)$ and $(\Phi_2, \Psi_2, \mathcal{H}, \varphi_2)$ be C^* -algebra-valued bipolar metric spaces. A covariant map $\Gamma : (\Phi_1, \Psi_1, \mathcal{H}, \varphi_1) \rightrightarrows (\Phi_2, \Psi_2, \mathcal{H}, \varphi_2)$ such that

$$\varphi_2(\Gamma(\eta), \Gamma(\sigma)) \leq \aleph^* \varphi_1(\eta, \sigma) \aleph \text{ for all } \eta \in \Phi_1, \sigma \in \Psi_1$$

or a contravariant map $\Gamma : (\Phi_1, \Psi_1, \mathcal{H}, \varphi_1) \leftrightsquigarrow (\Phi_2, \Psi_2, \mathcal{H}, \varphi_2)$ such that

$$\varphi_2(\Gamma(\sigma), \Gamma(\eta)) \leq \aleph^* \varphi_1(\eta, \sigma) \aleph \text{ for all } \eta \in \Phi_1, \sigma \in \Psi_1,$$

for some element $\aleph \in \mathcal{H}$, is called Lipschitz continuous. If $\aleph = 1$, then this covariant or contravariant map is said to be non-expansive, and if $\aleph \in \mathcal{H}$ with $\|\aleph\|^2 < 1$, it is called a contraction.

Example 2.8. Let $\mathcal{H} = \mathbb{C}$, then \mathcal{H} is a C^* -algebra with pointwise operations of addition, multiplication, and scalar multiplication. The norm on \mathcal{H} is defined by

$$\|(\eta, \sigma)\| = \max\{|\eta|, |\sigma|\}.$$

Let $\Phi = [0, 1]$, $\Psi = [1, 2]$ and $\varphi : \Phi \times \Psi \rightarrow \mathcal{H}_+$ be defined by

$$\varphi(\eta, \sigma) = |\eta - \sigma|,$$

for all $\eta \in \Phi$ and $\sigma \in \Psi$. Then $\Gamma : (\Phi, \Psi, \mathcal{H}, \varphi) \rightrightarrows (\Phi, \Psi, \mathcal{H}, \varphi)$, given by

$$\Gamma(\eta) = \frac{\eta + 4}{5}, \quad \forall \eta \in \Phi \cup \Psi$$

is continuous with respect to \mathcal{H} since

$$\|\varphi(\Gamma\eta, \Gamma\sigma)\| = \left\| \varphi\left(\frac{\eta + 4}{5}, \frac{\sigma + 4}{5}\right) \right\| = \left\| \frac{\eta}{5} - \frac{\sigma}{5} \right\| < \epsilon \text{ whenever } \|\eta - \sigma\| < \delta = 5\epsilon.$$

Clearly, Lipschitz continuous, which implies the continuity.

Definition 2.9. [23] Let $(\Phi, \Psi, \mathcal{H}, \varphi)$ be a C^* -algebra-valued bipolar metric space.

- (F1) A sequence $(\{\eta_\alpha\}, \{\sigma_\alpha\})$ on the set $\Phi \times \Psi$ is called a bisequence on $(\Phi, \Psi, \mathcal{H}, \varphi)$.
- (F2) A point $\eta \in \Phi \cup \Psi$ is said to be a left point if $\eta \in \Phi$, a right point if $\eta \in \Psi$ and a central point if both hold. Similarly, a sequence $\{\eta_\alpha\}$ on the set Φ and a sequence $\{\sigma_\alpha\}$ on the set Ψ are called a left and right sequence (with respect to \mathcal{H}), respectively.
- (F3) A sequence $\{\eta_\alpha\}$ converges to a point σ (with respect to \mathcal{H}) if $\{\eta_\alpha\}$ is a left sequence, σ is a right point and $\lim_{\alpha \rightarrow \infty} \varphi(\eta_\alpha, \sigma) = 0_{\mathcal{H}}$ or $\{\eta_\alpha\}$ is a right sequence, σ is a left point and $\lim_{\alpha \rightarrow \infty} \varphi(\sigma, \eta_\alpha) = 0_{\mathcal{H}}$.
- (F4) If both $\{\eta_\alpha\}$ and $\{\sigma_\alpha\}$ converge (with respect to \mathcal{H}), then the bisequence $(\{\eta_\alpha\}, \{\sigma_\alpha\})$ is said to be convergent (with respect to \mathcal{H}). If $\{\eta_\alpha\}$ and $\{\sigma_\alpha\}$ both converge (with respect to \mathcal{H}) to a same point $u \in \Phi \cap \Psi$, then this bisequence is said to be biconvergent (with respect to \mathcal{H}).
- (F5) A bisequence $(\{\eta_\alpha\}, \{\sigma_\alpha\})$ on $(\Phi, \Psi, \mathcal{H}, \varphi)$ is said to be a Cauchy bisequence (with respect to \mathcal{H}), if $\lim_{\alpha, m \rightarrow \infty} \varphi(\eta_\alpha, \sigma_m) = 0_{\mathcal{H}}$.
- (F6) $(\Phi, \Psi, \mathcal{H}, \varphi)$ is complete, if every Cauchy bisequence (with respect to \mathcal{H}) is convergent.

Proposition 2.10. In a C^* -algebra-valued bipolar metric space, every convergent Cauchy bisequence is biconvergent.

Proof. Let $(\Phi, \Psi, \mathcal{H}, \varphi)$ be a C^* -algebra-valued bipolar metric space and $(\{\eta_\alpha\}, \{\sigma_\alpha\})$ be a Cauchy bisequence, such that $\{\eta_\alpha\} \rightarrow \sigma \in \Psi$ and $\{\sigma_\alpha\} \rightarrow \eta \in \Phi$. Then $\varphi(\eta, \sigma) \leq \varphi(\eta, \sigma_m) + \varphi(\eta_\alpha, \sigma_m) + \varphi(\eta_\alpha, \sigma)$. So, being a convergent Cauchy bisequence implies $\varphi(\eta, \sigma) = 0$. Thus $(\eta_\alpha, \sigma_\alpha)$ biconverges to the point $\eta = \sigma$. \square

Let $(\Phi, \Psi, \mathcal{H}, \varphi)$ be a C^* -algebra-valued bipolar metric space. The set

$$\mathcal{B}_\varphi(\eta; \epsilon) = \{\sigma \in \Psi : \varphi(\eta, \sigma) < \epsilon\}$$

is called open ball of radius $0_{\mathcal{H}} < \epsilon \in \mathcal{H}$ and at center $\eta \in \Phi$. Similarly, the set

$$\mathcal{B}_\varphi[\eta; \epsilon] = \{\sigma \in \Psi : \varphi(\eta, \sigma) \leq \epsilon\}$$

is called closed ball of radius $0_{\mathcal{H}} < \epsilon \in \mathcal{H}$ and at center $\eta \in \Phi$. The set of open balls

$$\mathcal{U} = \{\mathcal{B}_\varphi(\eta; \epsilon) : \eta \in \Phi, \epsilon > 0_{\mathcal{H}}\},$$

form a basis of some topology τ_2 on Ψ . The set

$$\mathfrak{B}_\varphi(\sigma; \epsilon) = \{\eta \in \Phi : \varphi(\eta, \sigma) < \epsilon\}$$

is called open ball of radius $0_{\mathcal{H}} < \epsilon \in \mathcal{H}$ and at center $\sigma \in \Psi$. Similarly, the set

$$\mathfrak{B}_\varphi[\sigma; \epsilon] = \{\eta \in \Phi : \varphi(\eta, \sigma) \leq \epsilon\}$$

is called closed ball of radius $0_{\mathcal{H}} < \epsilon \in \mathcal{H}$ and at center $\sigma \in \Psi$. The set of open balls

$$\mathcal{V} = \{\mathfrak{B}_\varphi(\sigma; \epsilon) : \sigma \in \Psi, \epsilon > 0_{\mathcal{H}}\},$$

form a basis of some topology τ_1 on Φ . Let \mathbf{B} denote the family of all subsets of $\Phi \times \Psi$ of the form $U \times V$, where U is open in Φ and V open in Ψ . Then $\bigcup \mathbf{B} = \Phi \times \Psi$ and the intersection of any two members of \mathbf{B} lies in \mathbf{B} . Therefore \mathbf{B} is a base for a topology on $\Phi \times \Psi$. This topology is called the product topology.

3. Main results

Now, we present our main results.

Theorem 3.1. *Let $(\Phi, \Psi, \mathcal{H}, \varphi)$ be a complete C^* -algebra-valued bipolar metric space and given a covariant contraction $\Gamma : (\Phi, \Psi, \mathcal{H}, \varphi) \rightrightarrows (\Phi, \Psi, \mathcal{H}, \varphi)$. Then the mapping $\Gamma : \Phi \cup \Psi \rightarrow \Phi \cup \Psi$ has a unique fixed point.*

Proof. If $\mathcal{H} = \{0_{\mathcal{H}}\}$, then there is nothing to prove. Assume that $\mathcal{H} \neq \{0_{\mathcal{H}}\}$. Let $\eta_0 \in \Phi$ and $\sigma_0 \in \Psi$. For each $\alpha \in \mathbb{Z}^+ \cup \{0\}$, define $\Gamma(\eta_\alpha) = \eta_{\alpha+1}$ and $\Gamma(\sigma_\alpha) = \sigma_{\alpha+1}$. Therefore $(\{\eta_\alpha\}, \{\sigma_\alpha\})$ is a bisequence on $(\Phi, \Psi, \mathcal{H}, \varphi)$. Let $\mathcal{M} := \varphi(\eta_0, \sigma_0) + \varphi(\eta_0, \sigma_1)$ and $\mathcal{S} := \varphi(\eta_0, \sigma_0) + \varphi(\eta_1, \sigma_0)$. Then, for each $\alpha, p \in \mathbb{Z}^+$,

$$\begin{aligned} \varphi(\eta_\alpha, \sigma_\alpha) &= \varphi(\Gamma\eta_{\alpha-1}, \Gamma\sigma_{\alpha-1}) \\ &\leq \mathfrak{N}^* \varphi(\eta_{\alpha-1}, \sigma_{\alpha-1}) \mathfrak{N} \\ &= \mathfrak{N}^* \varphi(\Gamma\eta_{\alpha-2}, \Gamma\sigma_{\alpha-2}) \mathfrak{N} \\ &\leq (\mathfrak{N}^*)^2 \varphi(\eta_{\alpha-2}, \sigma_{\alpha-2}) \mathfrak{N}^2 \\ &\leq (\mathfrak{N}^*)^3 \varphi(\eta_{\alpha-3}, \sigma_{\alpha-3}) \mathfrak{N}^3 \end{aligned}$$

$$\begin{aligned} & \vdots \\ & \leq (\aleph^*)^\alpha \varphi(\eta_0, \sigma_0) \aleph^\alpha, \end{aligned}$$

$$\begin{aligned} \varphi(\eta_\alpha, \sigma_{\alpha+1}) &= \varphi(\Gamma\eta_{\alpha-1}, \Gamma\sigma_\alpha) \\ &\leq \aleph^* \varphi(\eta_{\alpha-1}, \sigma_\alpha) \aleph \\ &= \aleph^* \varphi(\Gamma\eta_{\alpha-2}, \Gamma\sigma_{\alpha-1}) \aleph \\ &\leq (\aleph^*)^2 \varphi(\eta_{\alpha-2}, \sigma_{\alpha-1}) \aleph^2 \\ &\leq (\aleph^*)^3 \varphi(\eta_{\alpha-3}, \sigma_{\alpha-2}) \aleph^3 \\ &\vdots \\ &\leq (\aleph^*)^\alpha \varphi(\eta_0, \sigma_1) \aleph^\alpha \end{aligned}$$

and

$$\begin{aligned} \varphi(\eta_{\alpha+1}, \sigma_\alpha) &= \varphi(\Gamma\eta_\alpha, \Gamma\sigma_{\alpha-1}) \\ &\leq \aleph^* \varphi(\eta_\alpha, \sigma_{\alpha-1}) \aleph \\ &= \aleph^* \varphi(\Gamma\eta_{\alpha-1}, \Gamma\sigma_{\alpha-2}) \aleph \\ &\leq (\aleph^*)^2 \varphi(\eta_{\alpha-1}, \sigma_{\alpha-2}) \aleph^2 \\ &\leq (\aleph^*)^3 \varphi(\eta_{\alpha-2}, \sigma_{\alpha-3}) \aleph^3 \\ &\vdots \\ &\leq (\aleph^*)^\alpha \varphi(\eta_1, \sigma_0) \aleph^\alpha. \end{aligned}$$

Also,

$$\begin{aligned} \varphi(\eta_{\alpha+p}, \sigma_\alpha) &\leq \varphi(\eta_{\alpha+p}, \sigma_{\alpha+1}) + \varphi(\eta_\alpha, \sigma_{\alpha+1}) + \varphi(\eta_\alpha, \sigma_\alpha) \\ &\leq \varphi(\eta_{\alpha+p}, \sigma_{\alpha+1}) + (\aleph^*)^\alpha \mathcal{M} \aleph^\alpha \\ &\leq \varphi(\eta_{\alpha+p}, \sigma_{\alpha+2}) + \varphi(\eta_{\alpha+1}, \sigma_{\alpha+2}) + \varphi(\eta_{\alpha+1}, \sigma_{\alpha+1}) + (\aleph^*)^\alpha \mathcal{M} \aleph^\alpha \\ &\leq \varphi(\eta_{\alpha+p}, \sigma_{\alpha+2}) + (\aleph^*)^{\alpha+1} \mathcal{M} \aleph^{\alpha+1} + (\aleph^*)^\alpha \mathcal{M} \aleph^\alpha \\ &\vdots \\ &\leq \varphi(\eta_{\alpha+p}, \sigma_{\alpha+p}) + (\aleph^*)^{\alpha+p-1} \mathcal{M} \aleph^{\alpha+p-1} + \dots + (\aleph^*)^{\alpha+1} \mathcal{M} \aleph^{\alpha+1} + (\aleph^*)^\alpha \mathcal{M} \aleph^\alpha \\ &\leq (\aleph^*)^{\alpha+p} \mathcal{M} \aleph^{\alpha+p} + (\aleph^*)^{\alpha+p-1} \mathcal{M} \aleph^{\alpha+p-1} + \dots + (\aleph^*)^{\alpha+1} \mathcal{M} \aleph^{\alpha+1} + (\aleph^*)^\alpha \mathcal{M} \aleph^\alpha \\ &= \sum_{\mathfrak{f}=\alpha}^{\alpha+p} (\aleph^*)^{\mathfrak{f}} \mathcal{M} \aleph^{\mathfrak{f}} \\ &= \sum_{\mathfrak{f}=\alpha}^{\alpha+p} (\aleph^*)^{\mathfrak{f}} \mathcal{M}^{\frac{1}{2}} \mathcal{M}^{\frac{1}{2}} \aleph^{\mathfrak{f}} \\ &= \sum_{\mathfrak{f}=\alpha}^{\alpha+p} (\mathcal{M}^{\frac{1}{2}} \aleph^{\mathfrak{f}})^* \mathcal{M}^{\frac{1}{2}} \aleph^{\mathfrak{f}} \end{aligned}$$

$$\begin{aligned}
&\leq \sum_{\mathfrak{t}=\alpha}^{\alpha+p} \|\mathcal{M}^{\frac{1}{2}} \mathfrak{N}^{\mathfrak{t}}\|^2 1_{\mathcal{H}} \\
&\leq \sum_{\mathfrak{t}=\alpha}^{\alpha+p} \|\mathcal{M}^{\frac{1}{2}}\|^2 \|\mathfrak{N}^{\mathfrak{t}}\|^2 1_{\mathcal{H}} \\
&\leq \|\mathcal{M}^{\frac{1}{2}}\|^2 \sum_{\mathfrak{t}=\alpha}^{\alpha+p} \|\mathfrak{N}\|^{2\mathfrak{t}} 1_{\mathcal{H}} \\
&\rightarrow 0_{\mathcal{H}} \text{ as } \alpha, p \rightarrow \infty, \text{ since } \|\mathfrak{N}\|^2 < 1,
\end{aligned}$$

and

$$\begin{aligned}
\varphi(\eta_{\alpha}, \sigma_{\alpha+p}) &\leq \varphi(\eta_{\alpha}, \sigma_{\alpha}) + \varphi(\eta_{\alpha+1}, \sigma_{\alpha}) + \varphi(\eta_{\alpha+1}, \sigma_{\alpha+p}) \\
&\leq (\mathfrak{N}^{\star})^{\alpha} \varphi(\eta_0, \sigma_0) \mathfrak{N}^{\alpha} + (\mathfrak{N}^{\star})^{\alpha} \varphi(\eta_1, \sigma_0) \mathfrak{N}^{\alpha} + \varphi(\eta_{\alpha+1}, \sigma_{\alpha+p}) \\
&\leq (\mathfrak{N}^{\star})^{\alpha} \mathfrak{S} \mathfrak{N}^{\alpha} + \varphi(\eta_{\alpha+1}, \sigma_{\alpha+1}) + \varphi(\eta_{\alpha+2}, \sigma_{\alpha+1}) + \varphi(\eta_{\alpha+2}, \sigma_{\alpha+p}) \\
&\leq (\mathfrak{N}^{\star})^{\alpha} \mathfrak{S} \mathfrak{N}^{\alpha} + (\mathfrak{N}^{\star})^{\alpha+1} \mathfrak{S} \mathfrak{N}^{\alpha+1} + \varphi(\eta_{\alpha+2}, \sigma_{\alpha+p}) \\
&\vdots \\
&\leq (\mathfrak{N}^{\star})^{\alpha} \mathfrak{S} \mathfrak{N}^{\alpha} + (\mathfrak{N}^{\star})^{\alpha+1} \mathfrak{S} \mathfrak{N}^{\alpha+1} + \dots + (\mathfrak{N}^{\star})^{\alpha+p-1} \mathfrak{S} \mathfrak{N}^{\alpha+p-1} + \varphi(\eta_{\alpha+p}, \sigma_{\alpha+p}) \\
&\leq (\mathfrak{N}^{\star})^{\alpha} \mathfrak{S} \mathfrak{N}^{\alpha} + (\mathfrak{N}^{\star})^{\alpha+1} \mathfrak{S} \mathfrak{N}^{\alpha+1} + \dots + (\mathfrak{N}^{\star})^{\alpha+p-1} \mathfrak{S} \mathfrak{N}^{\alpha+p-1} + (\mathfrak{N}^{\star})^{\alpha+p} \mathfrak{S} \mathfrak{N}^{\alpha+p} \\
&= \sum_{\mathfrak{t}=\alpha}^{\alpha+p} (\mathfrak{N}^{\star})^{\mathfrak{t}} \mathfrak{S} \mathfrak{N}^{\mathfrak{t}} \\
&= \sum_{\mathfrak{t}=\alpha}^{\alpha+p} (\mathfrak{N}^{\star})^{\mathfrak{t}} \mathfrak{S}^{\frac{1}{2}} \mathfrak{S}^{\frac{1}{2}} \mathfrak{N}^{\mathfrak{t}} \\
&= \sum_{\mathfrak{t}=\alpha}^{\alpha+p} (\mathfrak{S}^{\frac{1}{2}} \mathfrak{N}^{\mathfrak{t}})^{\star} \mathfrak{S}^{\frac{1}{2}} \mathfrak{N}^{\mathfrak{t}} \\
&\leq \sum_{\mathfrak{t}=\alpha}^{\alpha+p} \|\mathfrak{S}^{\frac{1}{2}} \mathfrak{N}^{\mathfrak{t}}\|^2 1_{\mathcal{H}} \\
&\leq \sum_{\mathfrak{t}=\alpha}^{\alpha+p} \|\mathfrak{S}^{\frac{1}{2}}\|^2 \|\mathfrak{N}^{\mathfrak{t}}\|^2 1_{\mathcal{H}} \\
&\leq \|\mathfrak{S}^{\frac{1}{2}}\|^2 \sum_{\mathfrak{t}=\alpha}^{\alpha+p} \|\mathfrak{N}\|^{2\mathfrak{t}} 1_{\mathcal{H}} \\
&\rightarrow 0_{\mathcal{H}} \text{ as } \alpha, p \rightarrow \infty, \text{ since } \|\mathfrak{N}\|^2 < 1.
\end{aligned}$$

Therefore, $(\{\eta_{\alpha}\}, \{\sigma_{\alpha+p}\})$ is a Cauchy bisequence with respect to \mathcal{H} . By completeness of $(\Phi, \Psi, \mathcal{H}, \varphi)$, $(\{\eta_{\alpha}\}, \{\sigma_{\alpha}\})$ converges, and as a convergent Cauchy bisequence, in particular it biconverges, it follows that $\eta_{\alpha} \rightarrow \mu$ and $\sigma_{\alpha} \rightarrow \mu$, where $\mu \in \Phi \cap \Psi$. Since Γ is continuous, $\Gamma(\eta_{\alpha}) \rightarrow \Gamma(\mu)$. Therefore, $\Gamma(\mu) = \mu$. Hence μ is a fixed point of Γ .

We now show uniqueness. Let $\omega \in \Psi$ be another fixed point of Γ . Then

$$0_{\mathcal{H}} \leq \varphi(\mu, \omega) = \varphi(\Gamma\mu, \Gamma\omega) \leq \mathfrak{N}^{\star} \varphi(\mu, \omega) \mathfrak{N}.$$

Using the norm of \mathcal{H} , we have

$$0 \leq \|\varphi(\mu, \omega)\| \leq \|\mathfrak{N}^* \varphi(\mu, \omega) \mathfrak{N}\| \leq \|\mathfrak{N}^*\| \|\varphi(\mu, \omega)\| \|\mathfrak{N}\| = \|\mathfrak{N}\|^2 \|\varphi(\mu, \omega)\|.$$

Since $\|\mathfrak{N}\|^2 < 1$, the above inequality holds only when $\varphi(\mu, \omega) = 0_{\mathcal{H}}$. Hence, $\mu = \omega$. Similar arguments hold if $\omega \in \Phi$. \square

Example 3.2. Let $\Phi = [0, 1]$, $\Psi = [1, 2]$, $\mathcal{H} = \mathcal{M}_2(\mathbb{C})$ and $\varphi : \Phi \times \Psi \rightarrow \mathcal{H}_+$ be defined by

$$\varphi(\eta, \sigma) = \begin{bmatrix} |\eta - \sigma| & 0 \\ 0 & \mathbb{k}|\eta - \sigma| \end{bmatrix}$$

for all $\eta \in \Phi$ and $\sigma \in \Psi$, where $\mathbb{k} \geq 0$ is a constant. Then $(\Phi, \Psi, \mathcal{H}, \varphi)$ is a complete C^* -algebra-valued bipolar metric space. Define $\Gamma : (\Phi, \Psi, \mathcal{H}, \varphi) \rightrightarrows (\Phi, \Psi, \mathcal{H}, \varphi)$ by

$$\Gamma(\eta) = \frac{\eta + 3}{4}, \quad \forall \eta \in \Phi \cup \Psi.$$

Then we get

$$\begin{aligned} \varphi(\Gamma\eta, \Gamma\sigma) &= \begin{bmatrix} |\Gamma\eta - \Gamma\sigma| & 0 \\ 0 & \mathbb{k}|\Gamma\eta - \Gamma\sigma| \end{bmatrix} \\ &= \begin{bmatrix} \left|\frac{\eta}{4} - \frac{\sigma}{4}\right| & 0 \\ 0 & \mathbb{k}\left|\frac{\eta}{4} - \frac{\sigma}{4}\right| \end{bmatrix} \\ &= \frac{1}{4} \begin{bmatrix} |\eta - \sigma| & 0 \\ 0 & \mathbb{k}|\eta - \sigma| \end{bmatrix} \\ &= \mathfrak{N}^* \varphi(\eta, \sigma) \mathfrak{N}, \end{aligned}$$

where

$$\mathfrak{N} = \begin{bmatrix} \frac{1}{2} & 0 \\ 0 & \frac{1}{2} \end{bmatrix}$$

and $\|\mathfrak{N}\| = \frac{1}{2} < 1$. All the conditions of Theorem 3.1 are fulfilled and Γ has a unique fixed point $\eta = 1$.

Below we prove a similar result for contravariant maps.

Theorem 3.3. Let $(\Phi, \Psi, \mathcal{H}, \varphi)$ be a complete C^* -algebra-valued bipolar metric space and given a contravariant contraction $\Gamma : (\Phi, \Psi, \mathcal{H}, \varphi) \rightrightarrows (\Phi, \Psi, \mathcal{H}, \varphi)$. Then the mapping $\Gamma : \Phi \cup \Psi \rightarrow \Phi \cup \Psi$ has a unique fixed point.

Proof. If $\mathcal{H} = \{0_{\mathcal{H}}\}$, then there is nothing to prove. Assume that $\mathcal{H} \neq \{0_{\mathcal{H}}\}$. Let $\eta_0 \in \Phi$. For each $\alpha \in \mathbb{Z}^+ \cup \{0\}$, define $\Gamma(\eta_\alpha) = \sigma_\alpha$ and $\Gamma(\sigma_\alpha) = \eta_{\alpha+1}$. Then $(\{\eta_\alpha\}, \{\sigma_\alpha\})$ is a bisequence on $(\Phi, \Psi, \mathcal{H}, \varphi)$. Let $\mathcal{G} := \varphi(\eta_0, \sigma_0)$. Then, for each $\alpha, p \in \mathbb{Z}^+$,

$$\begin{aligned} \varphi(\eta_\alpha, \sigma_\alpha) &= \varphi(\Gamma\sigma_{\alpha-1}, \Gamma\eta_\alpha) \\ &\leq \mathfrak{N}^* \varphi(\eta_\alpha, \sigma_{\alpha-1}) \mathfrak{N} \\ &= \mathfrak{N}^* \varphi(\Gamma\sigma_{\alpha-1}, \Gamma\eta_{\alpha-1}) \mathfrak{N} \end{aligned}$$

$$\begin{aligned}
&\leq (\mathbb{N}^*)^2 \varphi(\eta_{\alpha-1}, \sigma_{\alpha-1}) \mathbb{N}^2 \\
&\leq (\mathbb{N}^*)^4 \varphi(\eta_{\alpha-2}, \sigma_{\alpha-2}) \mathbb{N}^4 \\
&\vdots \\
&\leq (\mathbb{N}^*)^{2\alpha} \varphi(\eta_0, \sigma_0) \mathbb{N}^{2\alpha},
\end{aligned}$$

and

$$\begin{aligned}
\varphi(\eta_{\alpha+1}, \sigma_\alpha) &= \varphi(\Gamma\sigma_\alpha, \Gamma\eta_\alpha) \\
&\leq \mathbb{N}^* \varphi(\eta_\alpha, \sigma_\alpha) \mathbb{N} \\
&\leq (\mathbb{N}^*)^{2\alpha+1} \varphi(\eta_0, \sigma_0) \mathbb{N}^{2\alpha+1}.
\end{aligned}$$

Also,

$$\begin{aligned}
\varphi(\eta_{\alpha+p}, \sigma_\alpha) &\leq \varphi(\eta_{\alpha+p}, \sigma_{\alpha+1}) + \varphi(\eta_{\alpha+1}, \sigma_{\alpha+1}) + \varphi(\eta_{\alpha+1}, \sigma_\alpha) \\
&\leq \varphi(\eta_{\alpha+p}, \sigma_{\alpha+1}) + (\mathbb{N}^*)^{2\alpha+2} \mathcal{G} \mathbb{N}^{2\alpha+2} + (\mathbb{N}^*)^{2\alpha+1} \mathcal{G} \mathbb{N}^{2\alpha+1} \\
&\leq \varphi(\eta_{\alpha+p}, \sigma_{\alpha+2}) + \varphi(\eta_{\alpha+2}, \sigma_{\alpha+2}) + \varphi(\eta_{\alpha+2}, \sigma_{\alpha+1}) + (\mathbb{N}^*)^{2\alpha+2} \mathcal{G} \mathbb{N}^{2\alpha+2} \\
&\quad + (\mathbb{N}^*)^{2\alpha+1} \mathcal{G} \mathbb{N}^{2\alpha+1} \\
&\leq \varphi(\eta_{\alpha+p}, \sigma_{\alpha+2}) + (\mathbb{N}^*)^{2\alpha+4} \mathcal{G} \mathbb{N}^{2\alpha+4} + (\mathbb{N}^*)^{2\alpha+3} \mathcal{G} \mathbb{N}^{2\alpha+3} \\
&\quad + (\mathbb{N}^*)^{2\alpha+2} \mathcal{G} \mathbb{N}^{2\alpha+2} + (\mathbb{N}^*)^{2\alpha+1} \mathcal{G} \mathbb{N}^{2\alpha+1} \\
&\vdots \\
&\leq \varphi(\eta_{\alpha+p}, \sigma_{\alpha+p-1}) + (\mathbb{N}^*)^{2\alpha+2p-2} \mathcal{G} \mathbb{N}^{2\alpha+2p-2} \\
&\quad + \cdots + (\mathbb{N}^*)^{2\alpha+1} \mathcal{G} \mathbb{N}^{2\alpha+1} \\
&\leq (\mathbb{N}^*)^{2\alpha+2p-1} \mathcal{G} \mathbb{N}^{2\alpha+2p-1} + (\mathbb{N}^*)^{2\alpha+2p-2} \mathcal{G} \mathbb{N}^{2\alpha+2p-2} \\
&\quad + \cdots + (\mathbb{N}^*)^{2\alpha+1} \mathcal{G} \mathbb{N}^{2\alpha+1} \\
&= \sum_{\mathfrak{t}=2\alpha+1}^{2\alpha+2p-1} (\mathbb{N}^*)^{\mathfrak{t}} \mathcal{G} \mathbb{N}^{\mathfrak{t}} \\
&= \sum_{\mathfrak{t}=2\alpha+1}^{2\alpha+2p-1} (\mathbb{N}^*)^{\mathfrak{t}} \mathcal{G}^{\frac{1}{2}} \mathcal{G}^{\frac{1}{2}} \mathbb{N}^{\mathfrak{t}} \\
&= \sum_{\mathfrak{t}=2\alpha+1}^{2\alpha+2p-1} (\mathcal{G}^{\frac{1}{2}} \mathbb{N}^{\mathfrak{t}})^* (\mathcal{G}^{\frac{1}{2}} \mathbb{N}^{\mathfrak{t}}) \\
&\leq \sum_{\mathfrak{t}=2\alpha+1}^{2\alpha+2p-1} \|\mathcal{G}^{\frac{1}{2}} \mathbb{N}^{\mathfrak{t}}\|^2 1_{\mathcal{H}} \\
&\leq \sum_{\mathfrak{t}=2\alpha+1}^{2\alpha+2p-1} \|\mathcal{G}^{\frac{1}{2}}\|^2 \|\mathbb{N}^{\mathfrak{t}}\|^2 1_{\mathcal{H}} \\
&\leq \|\mathcal{G}^{\frac{1}{2}}\|^2 \sum_{\mathfrak{t}=2\alpha+1}^{2\alpha+2p-1} \|\mathbb{N}\|^{2\mathfrak{t}} 1_{\mathcal{H}} \\
&\rightarrow 0_{\mathcal{H}} \text{ as } \alpha, p \rightarrow \infty, \text{ since } \|\mathbb{N}\|^2 < 1,
\end{aligned}$$

and

$$\begin{aligned}\varphi(\eta_\alpha, \sigma_{\alpha+p}) &= \varphi(\Gamma\sigma_{\alpha-1}, \Gamma\eta_{\alpha+p}) \\ &\leq \mathfrak{N}^* \varphi(\eta_{\alpha+p}, \sigma_{\alpha-1}) \mathfrak{N}\end{aligned}$$

and apply the above case. Therefore, $(\{\eta_\alpha\}, \{\sigma_\alpha\})$ is a Cauchy bisequence with respect to \mathcal{H} . By completeness of $(\Phi, \Psi, \mathcal{H}, \varphi)$, $(\{\eta_\alpha\}, \{\sigma_\alpha\})$ converges, and as a convergent Cauchy bisequence, in particular it biconverges, it follows that $\eta_\alpha \rightarrow \mu$ and $\sigma_\alpha \rightarrow \mu$, where $\mu \in \Phi \cap \Psi$. Since Γ is continuous, $\Gamma(\eta_\alpha) \rightarrow \Gamma(\mu)$. Therefore, $\Gamma(\mu) = \mu$. Hence μ is a fixed point of Γ .

We now show uniqueness. Let $\omega \in \Phi \cap \Psi$ be another fixed point of Γ . Then

$$0_{\mathcal{H}} \leq \varphi(\mu, \omega) = \varphi(\Gamma\mu, \Gamma\omega) \leq \mathfrak{N}^* \varphi(\omega, \mu) \mathfrak{N}.$$

Using the norm of \mathcal{H} , we have

$$0 \leq \|\varphi(\mu, \omega)\| \leq \|\mathfrak{N}^* \varphi(\mu, \omega) \mathfrak{N}\| \leq \|\mathfrak{N}^*\| \|\varphi(\mu, \omega)\| \|\mathfrak{N}\| = \|\mathfrak{N}\|^2 \|\varphi(\mu, \omega)\|.$$

Since $\|\mathfrak{N}\|^2 < 1$, the above inequality holds only when $\varphi(\mu, \omega) = 0_{\mathcal{H}}$. Hence, $\mu = \omega$. \square

Example 3.4. Let $\Phi = \{0, 1, 2, 7\}$, $\Psi = \{0, \frac{2}{5}, \frac{7}{5}, 3\}$, $\mathcal{H} = \mathcal{M}_2(\mathbb{C})$ and $\varphi : \Phi \times \Psi \rightarrow \mathcal{H}_+$ be defined by

$$\varphi(\eta, \sigma) = \begin{bmatrix} |\eta - \sigma| & 0 \\ 0 & \mathbb{k}|\eta - \sigma| \end{bmatrix}$$

for all $\eta \in \Phi$ and $\sigma \in \Psi$, where $\mathbb{k} \geq 0$ is a constant. Then $(\Phi, \Psi, \mathcal{H}, \varphi)$ is a complete C^* -algebra-valued bipolar metric space. Define $\Gamma : (\Phi, \Psi, \mathcal{H}, \varphi) \rightleftarrows (\Phi, \Psi, \mathcal{H}, \varphi)$ by

$$\Gamma(\eta) = \begin{cases} \frac{\eta}{5}, & \text{if } \eta \in \{2, 7\}, \\ 0, & \text{if } \eta \in \{0, \frac{2}{5}, \frac{7}{5}, 1, 3\}. \end{cases}$$

Then we get

$$\begin{aligned}\varphi(\Gamma\sigma, \Gamma\eta) &= \begin{bmatrix} |\Gamma\sigma - \Gamma\eta| & 0 \\ 0 & \mathbb{k}|\Gamma\sigma - \Gamma\eta| \end{bmatrix} \\ &\leq \frac{1}{2} \begin{bmatrix} |\eta - \sigma| & 0 \\ 0 & \mathbb{k}|\eta - \sigma| \end{bmatrix} \\ &= \mathfrak{N}^* \varphi(\eta, \sigma) \mathfrak{N},\end{aligned}$$

where

$$\mathfrak{N} = \begin{bmatrix} \frac{1}{\sqrt{2}} & 0 \\ 0 & \frac{1}{\sqrt{2}} \end{bmatrix}$$

and $\|\mathfrak{N}\| = \frac{1}{\sqrt{2}} < 1$. All the conditions of Theorem 3.3 are fulfilled and Γ has a unique fixed point $\eta = 0$.

Theorem 3.5. Let $(\Phi, \Psi, \mathcal{H}, \varphi)$ be a complete C^* -algebra-valued bipolar metric space. Suppose $\Gamma : (\Phi, \Psi, \mathcal{H}, \varphi) \rightleftarrows (\Phi, \Psi, \mathcal{H}, \varphi)$ is contravariant mapping such that

$$\varphi(\Gamma(\sigma), \Gamma(\eta)) \leq \mathfrak{N}(\varphi(\eta, \Gamma\eta) + \varphi(\Gamma\sigma, \sigma)) \text{ for all } \eta \in \Phi, \sigma \in \Psi,$$

where $\mathfrak{N} \in \mathcal{H}'_+$ with $\|\mathfrak{N}\| < \frac{1}{2}$. Then the mapping $\Gamma : \Phi \cup \Psi \rightarrow \Phi \cup \Psi$ has a unique fixed point.

Proof. If $\mathcal{H} = \{0_{\mathcal{H}}\}$, then there is nothing to prove. Assume that $\mathcal{H} \neq \{0_{\mathcal{H}}\}$. Let $\eta_0 \in \Phi$. For each $\alpha \in \mathbb{Z}^+ \cup \{0\}$, define $\Gamma(\eta_\alpha) = \sigma_\alpha$ and $\Gamma(\sigma_\alpha) = \eta_{\alpha+1}$. Therefore $(\{\eta_\alpha\}, \{\sigma_\alpha\})$ is a bisequence on $(\Phi, \Psi, \mathcal{H}, \varphi)$. Let $\mathcal{G} := \varphi(\eta_0, \sigma_0)$. Then, for each $\alpha \in \mathbb{Z}^+$,

$$\begin{aligned}\varphi(\eta_\alpha, \sigma_\alpha) &= \varphi(\Gamma\sigma_{\alpha-1}, \Gamma\eta_\alpha) \\ &\leq \mathfrak{N}(\varphi(\eta_\alpha, \Gamma\eta_\alpha) + \varphi(\sigma_{\alpha-1}, \Gamma\sigma_{\alpha-1})) \\ &= \mathfrak{N}(\varphi(\eta_\alpha, \sigma_\alpha) + \varphi(\eta_\alpha, \sigma_{\alpha-1})),\end{aligned}$$

which implies that

$$(1 - \mathfrak{N})\varphi(\eta_\alpha, \sigma_\alpha) \leq \mathfrak{N}\varphi(\eta_\alpha, \sigma_{\alpha-1}).$$

Since $\|\mathfrak{N}\| < \frac{1}{2}$, $1 - \mathfrak{N}$ is invertible, and can be expressed as $(1 - \mathfrak{N})^{-1} = \sum_{\alpha=0}^{\infty} \mathfrak{N}^\alpha$, which together with $\mathfrak{N} \in \mathcal{H}'_+$ yield $(1 - \mathfrak{N})^{-1} \in \mathcal{H}'_+$. By Lemma 2.3 (A4), we know

$$\varphi(\eta_\alpha, \sigma_\alpha) \leq \mathfrak{h}\varphi(\eta_\alpha, \sigma_{\alpha-1}),$$

where $\mathfrak{h} = \mathfrak{N}(1 - \mathfrak{N})^{-1} \in \mathcal{H}'_+$. Now,

$$\begin{aligned}\varphi(\eta_\alpha, \sigma_{\alpha-1}) &= \varphi(\Gamma\sigma_{\alpha-1}, \Gamma\eta_{\alpha-1}) \\ &\leq \mathfrak{N}(\varphi(\eta_{\alpha-1}, \Gamma\eta_{\alpha-1}) + \varphi(\Gamma\sigma_{\alpha-1}, \sigma_{\alpha-1})) \\ &= \mathfrak{N}(\varphi(\eta_{\alpha-1}, \sigma_{\alpha-1}) + \varphi(\eta_\alpha, \sigma_{\alpha-1})),\end{aligned}$$

which implies that

$$(1 - \mathfrak{N})\varphi(\eta_\alpha, \sigma_{\alpha-1}) \leq \mathfrak{N}\varphi(\eta_{\alpha-1}, \sigma_{\alpha-1}).$$

As before, we get

$$\varphi(\eta_\alpha, \sigma_{\alpha-1}) \leq \mathfrak{h}\varphi(\eta_{\alpha-1}, \sigma_{\alpha-1}).$$

Therefore

$$\varphi(\eta_\alpha, \sigma_\alpha) \leq \mathfrak{h}^{2\alpha}\varphi(\eta_0, \sigma_0),$$

and

$$\varphi(\eta_\alpha, \sigma_{\alpha-1}) \leq \mathfrak{h}^{2\alpha-1}\varphi(\eta_0, \sigma_0).$$

Let $\alpha \leq m$, $\alpha, m \in \mathbb{Z}^+$, then we get

$$\begin{aligned}\varphi(\eta_\alpha, \sigma_m) &\leq \varphi(\eta_\alpha, \sigma_\alpha) + \varphi(\eta_{\alpha+1}, \sigma_\alpha) + \varphi(\eta_{\alpha+1}, \sigma_m) \\ &\leq \mathfrak{h}^{2\alpha}\varphi(\eta_0, \sigma_0) + \mathfrak{h}^{2\alpha+1}\varphi(\eta_0, \sigma_0) + \varphi(\eta_{\alpha+1}, \sigma_m) \\ &\vdots \\ &\leq \mathfrak{h}^{2\alpha}\varphi(\eta_0, \sigma_0) + \mathfrak{h}^{2\alpha+1}\varphi(\eta_0, \sigma_0) + \cdots + \mathfrak{h}^{2m}\varphi(\eta_0, \sigma_0) \\ &= (\mathfrak{h}^{2\alpha} + \mathfrak{h}^{2\alpha+1} + \cdots + \mathfrak{h}^{2m})\varphi(\eta_0, \sigma_0)\end{aligned}$$

$$\begin{aligned}
&= (\mathfrak{h}^{2\alpha} + \mathfrak{h}^{2\alpha+1} + \dots + \mathfrak{h}^{2m})\mathcal{G} \\
&\leq \|\mathfrak{h}^{2\alpha} + \mathfrak{h}^{2\alpha+1} + \dots + \mathfrak{h}^{2m}\| \|\mathcal{G}\| 1_{\mathcal{H}} \\
&\leq (\|\mathfrak{h}\|^{2\alpha} + \|\mathfrak{h}\|^{2\alpha+1} + \dots + \|\mathfrak{h}\|^{2m}) \|\mathcal{G}\| 1_{\mathcal{H}} \\
&= \frac{\|\mathfrak{h}\|^{2\alpha}}{1 - \|\mathfrak{h}\|} \|\mathcal{G}\| 1_{\mathcal{H}} \\
&\rightarrow 0_{\mathcal{H}} \text{ as } \alpha, m \rightarrow \infty, \text{ since } \|\mathfrak{h}\| < 1 \text{ by Lemma 2.3(A2)}.
\end{aligned}$$

Let $m < \alpha$, $\alpha, m \in \mathbb{Z}^+$, then we get

$$\begin{aligned}
\varphi(\eta_\alpha, \sigma_m) &\leq \varphi(\eta_{m+1}, \sigma_m) + \varphi(\eta_{m+1}, \sigma_{m+1}) + \varphi(\eta_\alpha, \sigma_{m+1}) \\
&\leq \mathfrak{h}^{2m+1} \varphi(\eta_0, \sigma_0) + \mathfrak{h}^{2m+2} \varphi(\eta_0, \sigma_0) + \varphi(\eta_\alpha, \sigma_{m+1}) \\
&\vdots \\
&\leq \mathfrak{h}^{2m+1} \varphi(\eta_0, \sigma_0) + \mathfrak{h}^{2m+2} \varphi(\eta_0, \sigma_0) + \dots + \mathfrak{h}^{2\alpha} \varphi(\eta_0, \sigma_0) \\
&= (\mathfrak{h}^{2m+1} + \mathfrak{h}^{2m+2} + \dots + \mathfrak{h}^{2\alpha}) \varphi(\eta_0, \sigma_0) \\
&= (\mathfrak{h}^{2m+1} + \mathfrak{h}^{2m+2} + \dots + \mathfrak{h}^{2\alpha}) \mathcal{G} \\
&\leq \|\mathfrak{h}^{2m+1} + \mathfrak{h}^{2m+2} + \dots + \mathfrak{h}^{2\alpha}\| \|\mathcal{G}\| 1_{\mathcal{H}} \\
&\leq (\|\mathfrak{h}\|^{2m+1} + \|\mathfrak{h}\|^{2m+2} + \dots + \|\mathfrak{h}\|^{2\alpha}) \|\mathcal{G}\| 1_{\mathcal{H}} \\
&= \frac{\|\mathfrak{h}\|^{2m+1}}{1 - \|\mathfrak{h}\|} \|\mathcal{G}\| 1_{\mathcal{H}} \\
&\rightarrow 0_{\mathcal{H}} \text{ as } \alpha, m \rightarrow \infty, \text{ since } \|\mathfrak{h}\| < 1 \text{ by Lemma 2.3(A2)}.
\end{aligned}$$

Therefore, $(\{\eta_\alpha\}, \{\sigma_\alpha\})$ is a Cauchy bisequence with respect to \mathcal{H} . By completeness of $(\Phi, \Psi, \mathcal{H}, \varphi)$, $(\{\eta_\alpha\}, \{\sigma_\alpha\})$ converges, and as a convergent Cauchy bisequence, in particular it biconverges, it follows that $\eta_\alpha \rightarrow \mu$ and $\sigma_\alpha \rightarrow \mu$, where $\mu \in \Phi \cap \Psi$. Then

$$\varphi(\Gamma\eta_\alpha, \Gamma\mu) \leq \mathfrak{N}(\varphi(\mu, \Gamma\mu) + \varphi(\Gamma\eta_\alpha, \eta_\alpha)).$$

As $\alpha \rightarrow \infty$,

$$\varphi(\mu, \Gamma\mu) \leq \mathfrak{N}\varphi(\mu, \Gamma\mu).$$

Hence μ is a fixed point of Γ .

We now show uniqueness. Let $\omega \in \Phi \cap \Psi$ be another fixed point of Γ . Then

$$\varphi(\mu, \omega) = \varphi(\Gamma\mu, \Gamma\omega) \leq \mathfrak{N}(\varphi(\omega, \Gamma\omega) + \varphi(\Gamma\mu, \mu)) = \mathfrak{N}(\varphi(\omega, \omega) + \varphi(\mu, \mu)) = 0.$$

Hence, $\mu = \omega$. □

4. Application

In this section, we study the existence and unique solution to an integral equation as an application of Theorem 3.1.

Theorem 4.1. *Let us consider the integral equation*

$$\eta(t) = q(t) + \int_{\mathcal{H}_1 \cup \mathcal{H}_2} \mathcal{G}(t, s, \eta(s)) ds, \quad t \in \mathcal{H}_1 \cup \mathcal{H}_2,$$

where $\mathcal{H}_1 \cup \mathcal{H}_2$ is a Lebesgue measurable set. Suppose

(T1) $\mathcal{G} : (\mathcal{H}_1 \cup \mathcal{H}_2) \times (\mathcal{H}_1 \cup \mathcal{H}_2) \times [0, \infty) \rightarrow [0, \infty)$ and $q \in L^\infty(\mathcal{H}_1) \cap L^\infty(\mathcal{H}_2)$,

(T2) there is a continuous function $\theta : (\mathcal{H}_1 \cup \mathcal{H}_2) \times (\mathcal{H}_1 \cup \mathcal{H}_2) \rightarrow [0, \infty)$ such that

$$|\mathcal{G}(t, s, \eta(s)) - \mathcal{G}(t, s, \sigma(s))| \leq \frac{1}{2} |\theta(t, s)| |\eta(s) - \sigma(s)|,$$

for all $t, s \in \mathcal{H}_1 \cup \mathcal{H}_2$,

(T3) $\sup_{t \in \mathcal{H}_1 \cup \mathcal{H}_2} \int_{\mathcal{H}_1 \cup \mathcal{H}_2} |\theta(t, s)| ds \leq 1$.

Then the integral equation has a unique solution in $L^\infty(\mathcal{H}_1) \cup L^\infty(\mathcal{H}_2)$.

Proof. Let $\Phi = L^\infty(\mathcal{H}_1)$ and $\Psi = L^\infty(\mathcal{H}_2)$ be two normed linear spaces, where $\mathcal{H}_1, \mathcal{H}_2$ are Lebesgue measurable sets and $m(\mathcal{H}_1 \cup \mathcal{H}_2) < \infty$. Let $\mathcal{H} = L^2(\mathcal{H}_1 \cup \mathcal{H}_2)$. Consider $\varphi : \Phi \times \Psi \rightarrow L(\mathcal{H})$ defined by $\varphi(\eta, \sigma) = \sup_{t \in \mathcal{H}_1 \cup \mathcal{H}_2} |\eta(t) - \sigma(t)|$ for all $\eta \in \Phi$ and $\sigma \in \Psi$. Then $(\Phi, \Psi, \mathcal{H}, \varphi)$ is a complete C^* -algebra-valued bipolar metric space. Define $\Gamma : \Phi \cup \Psi \rightarrow \Phi \cup \Psi$ by

$$\Gamma(\eta(t)) = q(t) + \int_{\mathcal{H}_1 \cup \mathcal{H}_2} \mathcal{G}(t, s, \eta(s)) ds, \quad t \in \mathcal{H}_1 \cup \mathcal{H}_2.$$

We claim that Γ is a covariant mapping. For this, let $\eta \in \Phi$. Then

$$\begin{aligned} \Gamma(\eta(t)) &= q(t) + \int_{\mathcal{H}_1 \cup \mathcal{H}_2} \mathcal{G}(t, s, \eta(s)) ds \\ &\in \Phi. \end{aligned}$$

Let $\sigma \in \Psi$. Then

$$\begin{aligned} \Gamma(\sigma(t)) &= q(t) + \int_{\mathcal{H}_1 \cup \mathcal{H}_2} \mathcal{G}(t, s, \sigma(s)) ds \\ &\in \Psi. \end{aligned}$$

Therefore, Γ is a covariant mapping. For any $\eta \in L^\infty(\mathcal{H}_1), \sigma \in L^\infty(\mathcal{H}_2)$,

$$\begin{aligned} \varphi(\Gamma\eta, \Gamma\sigma) &= \sup_{t \in \mathcal{H}_1 \cup \mathcal{H}_2} |\Gamma\eta(t) - \Gamma\sigma(t)| \\ &= \sup_{t \in \mathcal{H}_1 \cup \mathcal{H}_2} \int_{\mathcal{H}_1 \cup \mathcal{H}_2} |\mathcal{G}(t, s, \eta(s)) - \mathcal{G}(t, s, \sigma(s))| ds \\ &\leq \sup_{t \in \mathcal{H}_1 \cup \mathcal{H}_2} \int_{\mathcal{H}_1 \cup \mathcal{H}_2} \frac{1}{2} |\theta(t, s)| |\eta(s) - \sigma(s)| ds \\ &\leq \frac{1}{2} \varphi(\eta, \sigma) \\ &= \aleph^* \varphi(\eta, \sigma) \aleph, \end{aligned}$$

where $\aleph = \frac{1}{\sqrt{2}}$ and $\|\aleph\| = \frac{1}{\sqrt{2}} < 1$. Since $\|\aleph\| < 1$, the mapping Γ is a covariant contraction. Therefore, all the conditions of Theorem 3.1 are fulfilled. Hence, the integral equation has a unique solution. \square

5. Application to electric circuit differential equation

In this section, we study the existence and unique solution to an electric circuit differential equation as an application of Theorem 3.1.

Let us consider a series electric circuit which contain a resistor (\mathcal{R} , Ohms) a capacitor (C , Faradays), an inductor (\mathcal{L} , Henries) a voltage (\mathcal{V} , Volts) and an electromotive force (\mathcal{E} , Volts), as in the following scheme, Figure 1.

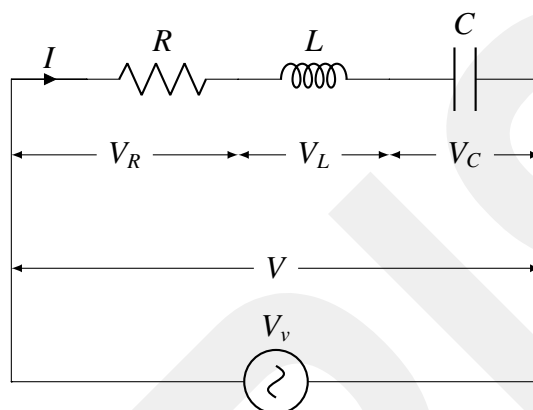

Figure 1. Series RLC.

Considering the definition of the intensity of electric current $I = \frac{dq}{dt}$, where q denote the electric charge and t -the time, let us recall the following usual formulas:

- $\mathcal{V}_R = I\mathcal{R}$;
- $\mathcal{V}_C = \frac{q}{C}$
- $\mathcal{V}_L = \mathcal{L}\frac{dI}{dt}$

Since in a series circuit there is only one current flowing, then I have the same value in the entire circuit. Kirchhoff's Voltage Law is the second of his fundamental laws we can use for circuit analysis. His voltage law states that for a closed loop series path the algebraic sum of all the voltages around any closed loop in a circuit is equal to zero. The Kirchhoff's Voltage Law states: "The algebraic sum of all the voltages around any closed loop in a circuit is equal to zero".

The main idea of the Kirchhoff's Voltage Law is that as you move around a closed loop/circuit, you will end up back to where you started in the circuit. Therefore you come back to the same initial potential without voltage losses around the loop. Therefore, any voltage drop around the loop must be equal to any voltage source encountered along the way. Mathematical expression of this consequence of the Kirchhoff's Voltage Law is: "the sum of voltage rises across any loops is equal to the sum of voltage drops across that loop". Then we have the following relation:

$$\mathcal{I}\mathcal{R} + \frac{q}{C} + \mathcal{L}\frac{d\mathcal{I}}{dt} = \mathcal{V} = \mathcal{V}_v(t) = \mathfrak{f}(t, q(t)).$$

We can write this voltage equation in the parameters of a second-order differential equation as follows.

$$\mathcal{L}\frac{d^2q}{dt^2} + \mathcal{R}\frac{dq}{dt} + \frac{q}{C} = \mathcal{V}_v(t) = \mathfrak{f}(t, q(t)), \text{ with the initial conditions, } q(0) = 0, q'(0) = 0, \quad (5.1)$$

where $\tau = \frac{\mathcal{R}}{2\mathcal{L}}$ - the nondimensional time for the resonance case in Physics. The Green function associated with Eq 5.1 is the following:

$$\mathcal{G}(t, s) = \frac{1}{\mathcal{L}}(t - s)e^{-\tau(t-s)},$$

where $C = \frac{4\mathcal{L}}{\mathcal{R}^2}$. In these conditions, the differential problem 5.1 can be written as the following integral equation.

$$\eta(t) = \int_0^t \mathcal{G}(t, s)\mathfrak{f}(s, \eta(s))ds, \text{ where } t \in [0, 1] \quad (5.2)$$

and $\mathfrak{f} : [0, 1] \times \mathbb{R} \rightarrow \mathbb{R}$ is a continuous function such that for all $s \in [0, 1]$, $\mathfrak{f}(s, 0) = 0$. Let $\Phi = (C[0, 1], [0, +\infty))$ be the set of all continuous functions defined on $[0, 1]$ with values in the interval $[0, +\infty)$ and $\Psi = (C[0, 1], (-\infty, 0])$ be the set of all continuous functions defined on $[0, 1]$ with values in the interval $(-\infty, 0]$. Let $\mathcal{H} = \mathcal{M}_2(\mathbb{C})$ and $\varphi : \Phi \times \Psi \rightarrow \mathcal{H}_+$ to be defined by

$$\varphi(\eta, \sigma) = \begin{bmatrix} \sup_{t \in [0, 1]} |\eta(t) - \sigma(t)| & 0 \\ 0 & \mathbb{k} \sup_{t \in [0, 1]} |\eta(t) - \sigma(t)| \end{bmatrix}$$

for all $\eta \in \Phi$ and $\sigma \in \Psi$, where $\mathbb{k} \geq 0$ is a constant. Then $(\Phi, \Psi, \mathcal{H}, \varphi)$ is a complete C^* -algebra-valued bipolar metric space.

Further, let us give the main result of the section.

Theorem 5.1. *Let $\Gamma : (\Phi, \Psi, \mathcal{H}, \varphi) \rightrightarrows (\Phi, \Psi, \mathcal{H}, \varphi)$ be a function such that the following assertions hold:*

- (i) \mathcal{G} is the Green function defined as above;
- (ii) $\mathfrak{f} : [0, 1] \times \mathbb{R} \rightarrow \mathbb{R}$ is a continuous function such that for all $s \in [0, 1]$, $\mathfrak{f}(s, 0) = 0$ and for $(\eta, \sigma) \in (\Phi, \Psi)$, we have the inequality:

$$|\mathfrak{f}(t, \eta) - \mathfrak{f}(t, \sigma)| \leq \frac{1}{2}|\eta(t) - \sigma(t)|.$$

Then the voltage differential equation (5.1) has a unique solution in $\Phi \cup \Psi$.

Proof. Define $\Gamma : \Phi \cup \Psi \rightarrow \Phi \cup \Psi$ by

$$\Gamma\eta(t) = \int_0^t \mathcal{G}(t, s)\mathfrak{f}(s, \eta(s))ds.$$

We claim that Γ is a covariant mapping. For this, let $\eta \in \Phi$. Then

$$\Gamma(\eta(t)) = \int_0^t \mathcal{G}(t, s) \tilde{f}(s, \eta(s)) ds \\ \in \Phi.$$

Let $\sigma \in \Psi$. Then

$$\Gamma(\sigma(t)) = \int_0^t \mathcal{G}(t, s) \tilde{f}(s, \sigma(s)) ds \\ \in \Psi.$$

Therefore, Γ is a covariant mapping. Now,

$$\begin{aligned} \varphi(\Gamma\eta, \Gamma\sigma) &= \begin{bmatrix} \sup_{t \in [0,1]} |\Gamma\eta(t) - \Gamma\sigma(t)| & 0 \\ 0 & \mathbb{k} \sup_{t \in [0,1]} |\Gamma\eta(t) - \Gamma\sigma(t)| \end{bmatrix} \\ &\leq \begin{bmatrix} \sup_{t \in [0,1]} \int_0^t \mathcal{G}(t, s) |\tilde{f}(s, \eta(s)) - \tilde{f}(s, \sigma(s))| ds & 0 \\ 0 & \mathbb{k} \sup_{t \in [0,1]} \int_0^t \mathcal{G}(t, s) |\tilde{f}(s, \eta(s)) - \tilde{f}(s, \sigma(s))| ds \end{bmatrix} \\ &\leq \begin{bmatrix} \frac{1}{2} \sup_{t \in [0,1]} |\eta(t) - \sigma(t)| & 0 \\ 0 & \mathbb{k} \frac{1}{2} \sup_{t \in [0,1]} |\eta(t) - \sigma(t)| \end{bmatrix} \\ &= \frac{1}{2} \begin{bmatrix} \sup_{t \in [0,1]} |\eta(t) - \sigma(t)| & 0 \\ 0 & \mathbb{k} \sup_{t \in [0,1]} |\eta(t) - \sigma(t)| \end{bmatrix} \\ &= \mathfrak{N}^* \varphi(\eta, \sigma) \mathfrak{N}, \end{aligned}$$

where

$$\mathfrak{N} = \begin{bmatrix} \frac{1}{\sqrt{2}} & 0 \\ 0 & \frac{1}{\sqrt{2}} \end{bmatrix}$$

and $\|\mathfrak{N}\| = \frac{1}{\sqrt{2}} < 1$. Therefore,

$$\varphi(\Gamma\eta, \Gamma\sigma) \leq \mathfrak{N}^* \varphi(\eta, \sigma) \mathfrak{N}.$$

Hence, all the conditions of Theorem 3.1 are satisfied. Thus, the differential voltage equation (5.1) has a unique solution. \square

6. Conclusions

Firstly, we proved existence and uniqueness fixed point theorems on C^* -algebra-valued bipolar metric space. Then, to validate our main theorems, we have given two examples and an applications to find the unique solution of the integral equation and electric circuit differential equation via C^* -algebra-valued bipolar metric space. Readers can explore extending the results in the setting of C^* -algebra-valued bipolar p-metric space.

Conflict of interest

The authors declare that they have no competing interests concerning the publication of this article.

References

1. M. M. Fréchet, *Sur quelques points du calcul fonctionnel*, Rendiconti del Circolo Matematico di Palermo, **22** (1906), 1–72.
2. H. Aydi, W. Shatanawi, C. Vetro, On generalized weak G-contraction mapping in G-metric spaces, *Comput. Math. Appl.*, **62** (2011), 4222–4229. <https://doi.org/10.1016/j.camwa.2011.10.007>
3. Z. Mustafa, B. Sims, A new approach to generalized metric spaces, *J. Nonlinear Convex Anal.*, **7** (2006), 289–297.
4. T. Rasham, P. Agarwal, L. S. Abbasi, S. Jain, A study of some new multivalued fixed point results in a modular like metric space with graph, *J. Anal.*, **30** (2022), 833–844. <https://doi.org/10.1007/s41478-021-00372-z>
5. T. Rasham, M. Nazam, H. Aydi, A. Shoaib, C. Park, J. R. Lee, Hybrid pair of multivalued mappings in modular-like metric spaces and applications, *AIMS Math.*, **7** (2022), 10582–10595. <https://doi.org/10.3934/math.2022590>
6. T. Rasham, A. Shoaib, S. Alshoraify, C. Park, J. R. Lee, Study of multivalued fixed point problems for generalized contractions in double controlled dislocated quasi metric type spaces, *AIMS Math.*, **7** (2022), 1058–1073. <https://doi.org/10.3934/math.2022063>
7. M. Gamal, T. Rasham, W. Cholamjiak, F. G. Shi, C. Park, New iterative scheme for fixed point results of weakly compatible maps in multiplicative G_M -metric space via various contractions with application, *AIMS Math.*, **7** (2022), 13681–13703. <https://doi.org/10.3934/math.2022754>
8. T. Rasham, M. De La Sen, A novel study for hybrid pair of multivalued dominated mappings in b-multiplicative metric space with applications, *J. Inequal. Appl.*, **107** (2022). <https://doi.org/10.1186/s13660-022-02845-6>
9. T. Rasham, M. Nazam, H. Aydi, R. P. Agarwal, Existence of common fixed points of generalized Δ -implicit locally contractive mappings on closed ball in multiplicative G-metric spaces with applications, *Mathematics*, **10** (2022), 3369. <https://doi.org/10.3390/math10183369>
10. A. Mutlu, U. Gürdal, An infinite dimensional fixed point theorem on function spaces of ordered metric spaces, *Kuwait J. Sci.*, **42** (2015), 36–49. <https://doi.org/10.1016/j.langcom.2015.03.001>
11. A. Mutlu, U. Gürdal, Bipolar metric spaces and some fixed point theorems, *J. Nonlinear Sci. Appl.*, **9** (2016), 5362–5373. <http://dx.doi.org/10.22436/jnsa.009.09.05>
12. U. Gürdal, A. Mutlu, K. Özkan, Fixed point results for α - ψ -contractive mappings in bipolar metric spaces, *J. Inequal. Spec. Funct.*, **11** (2020), 64–75.
13. G. N. V. Kishore, R. P. Agarwal, B. S. Rao, R. V. N. S. Rao, Caristi type cyclic contraction and common fixed point theorems in bipolar metric spaces with applications, *Fixed Point Theory A.*, **2018** (2018), 21. <https://doi.org/10.1186/s13663-018-0646-z>

14. G. N. V. Kishore, D. R. Prasad, B. S. Rao, V. S. Baghavan, Some applications via common coupled fixed point theorems in bipolar metric spaces, *J. Crit. Rev.*, **7** (2020), 601–607.
15. G. N. V. Kishore, K. P. R. Rao, A. Sombabu, R. V. N. S. Rao, Related results to hybrid pair of mappings and applications in bipolar metric spaces, *J. Math.*, **2019** (2019), 8485412. <https://doi.org/10.1155/2019/8485412>
16. B. S. Rao, G. N. V. Kishore, G. K. Kumar, Geraghty type contraction and common coupled fixed point theorems in bipolar metric spaces with applications to homotopy, *Int. J. Math. Trends Technol.*, **63** (2018), 25–34. <http://dx.doi.org/10.14445/22315373/IJMTT-V63P504>
17. G. N. V. Kishore, K. P. R. Rao, H. Işık, B. S. Rao, A. Sombabu, Covarian mappings and coupled fixed point results in bipolar metric spaces, *Int. J. Nonlinear Anal. Appl.*, **12** (2021), 1–15. <http://dx.doi.org/10.22075/IJNAA.2021.4650>
18. A. Mutlu, K. Özkan, U. Gürdal, Locally and weakly contractive principle in bipolar metric spaces, *TWMS J. Appl. Eng. Math.*, **10** (2020), 379–388.
19. Y. U. Gaba, M. Aphane, H. Aydi, (α, BK) -contractions in bipolar metric spaces, *J. Math.*, **2021** (2021), 5562651. <https://doi.org/10.1155/2021/5562651>
20. K. Roy, M. Saha, R. George, L. Gurand, Z. D. Mitrović, Some covariant and contravariant fixed point theorems over bipolar p-metric spaces and applications, *Filomat*, **36** (2022), 1755–1767. <https://doi.org/10.2298/FIL2205755R>
21. Z. H. Ma, L. N. Jiang, H. K. Sun, C^* -algebras-valued metric spaces and related fixed point theorems, *Fixed Point Theory A.*, **2014** (2014), 206. <https://doi.org/10.1186/1687-1812-2014-206>
22. S. Batul, T. Kamran, C^* -valued contractive type mappings, *Fixed Point Theory A.*, **2015** (2015), 142. <https://doi.org/10.1186/s13663-015-0393-3>
23. M. Gunaseelan, G. Arul Joseph, A. Ul Haq, I. A. Baloch, F. Jarad, Coupled fixed point theorems on C^* -algebra-valued bipolar metric spaces. *AIMS Math.*, **7** (2022), 7552–7568. <http://dx.doi.org/10.3934/math.2022424>
24. K. R. Davidson, *C^* -algebras by example*, Fields Institute Monographs, American Mathematical Society, 1996.
25. G. J. Murphy, *C^* -algebra and operator theory*, London, Academic Press, 1990.
26. Q. H. Xu, T. E. D. Bieke, Z. Q. Chen, *Introduction to operator algebras and noncommutative L_p spaces*, Beijing, Science Press, 2010.



AIMS Press

© 2023 the Author(s), licensee AIMS Press. This is an open access article distributed under the terms of the Creative Commons Attribution License (<http://creativecommons.org/licenses/by/4.0>)