



**LEAN SIX-SIGMA METHODOLOGY AND AN APPLICATION IN A  
DEFENSE INDUSTRY COMPANY**

**BURAK ALPER**

**SEPTEMBER 2019**

LEAN SIX-SIGMA METHODOLOGY AND AN APPLICATION IN A DEFENSE  
INDUSTRY COMPANY

A THESIS SUBMITTED TO  
THE GRADUATE SCHOOL OF NATURAL AND APPLIED  
SCIENCES OF  
ÇANKAYA UNIVERSITY

BY  
BURAK ALPER

IN PARTIAL FULFILLMENT OF THE REQUIREMENTS FOR THE  
DEGREE OF  
MASTER OF SCIENCE  
IN  
INDUSTRIAL ENGINEERING  
DEPARTMENT

SEPTEMBER 2019

Title of the Thesis: **Lean Six-sigma Methodology and An Application in A Defense Industry Company**

Submitted by **Burak ALPER**

Approval of the Graduate School of Natural and Applied Sciences, Çankaya University.



Prof. Dr. Can ÇOĞUN

Director

I certify that this thesis satisfies all the requirements as a thesis for the degree of Master of Science.

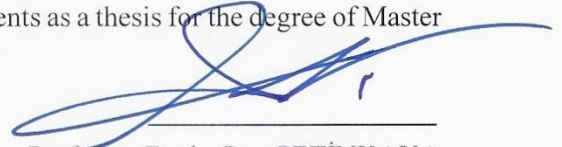

Assoc. Prof. Dr. Ferda Can ÇETİNKAYA

Head of Department

This is to certify that we have read this thesis and that in our opinion it is fully adequate, in scope and quality, as a thesis for the degree of Master of Science.

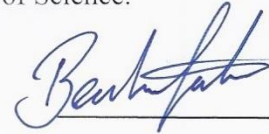

Assist. Prof. Dr. Behür SATIR

Supervisor

**Examination Date: 11.09.2019**

**Examining Committee Members**

Assoc. Prof. Dr. Hakan ÇERÇİOĞLU (Gazi Uni.)

Assist. Prof. Dr. Behür SATIR (Çankaya Uni.)

Assist. Prof. Dr. Hakan ÖZAKTAŞ (Çankaya Uni.)



## STATEMENT OF NON-PLAGIARISM PAGE

I hereby declare that all information in this document has been obtained and presented in accordance with academic rules and ethical conduct. I also declare that, as required by this rules and conduct, I have fully cited and referenced all material and results that are not original to this work.

Name, Last Name: Burak ALPER

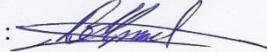
Signature : 

Date : 11.09.2019

## ABSTRACT

### LEAN SIX-SIGMA METHODOLOGY AND AN APPLICATION IN A DEFENSE INDUSTRY COMPANY

ALPER, Burak

M.Sc., Department of Industrial Engineering

Supervisor: Assist. Prof. Dr. Behür SATIR

September 2019, 75 Pages

This study aims to give a clear understanding of lean six-sigma approach and show that it is possible to make significant improvements by making little differences in production processes. In the first chapter of the study; lean manufacturing is explained in depth. Starting from the history, four subsections explain the prospects of lean manufacturing. The principles and tools used in lean manufacturing are given in detail. In the second chapter; the detailed information about six-sigma methodology is given. Starting from the history, major perspectives, success criteria, the DMAIC approach, operational benefits, advantages & disadvantages and the organizational structure of six-sigma are explained. The combination of lean and six-sigma, the lean six-sigma approach is defined, and the essentials of it are given to better understand why this balanced approach is better. Finally, an application that has been brought to life in a press brake workstation, and obtained results are explained.

**Keywords:** lean manufacturing, six-sigma methodology, DMAIC, lean six-sigma approach, defense industry

## ÖZ

### YALIN ALTI SİGMA METODOLOJİSİ VE BİR SAVUNMA SANAYİ FİRMASINDA UYGULAMASI

ALPER, Burak

Yüksek Lisans, Endüstri Mühendisliği Anabilim Dalı

Tez Yöneticisi: Dr. Öğr. Üy. Behür SATIR

Eylül 2019, 75 Sayfa

Bu tez çalışması, yalın altı sigma yaklaşımının açık bir şekilde anlaşılmasını sağlamayı ve üretim süreçlerinde çok az fark yaratarak önemli iyileştirmeler yapmanın mümkün olduğunu göstermeyi amaçlamaktadır. Çalışmanın birinci bölümünde; tarihçesinden başlayarak, dört alt bölüm içerisinde yalın üretim kavramı derinlemesine açıklanmıştır. Yalın imalatta kullanılan ilke ve araçlar detaylı olarak verilmiştir. İkinci bölümde; altı-sigma metodolojisi hakkında detaylı bilgi verilmektedir. Tarihçesinden başlayarak, ana bakış açıları, başarı kriterleri, TÖAİK yaklaşımı, operasyonel faydalar, avantajları, dezavantajları ve altı sigmanın organizasyon yapısı açıklanmaktadır. Yalın ve altı sigmanın harmanlanması ile ortaya çıkan “yalın altı sigma yaklaşımı” tanımlanmıştır ve bu dengeli yaklaşımın neden daha iyi olduğunu daha iyi anlamak için esasları verilmiştir. Son olarak; bir abkant pres istasyonunda hayata geçirilen yalın altı sigma uygulaması ve elde edilen sonuçlar açıklanmıştır.

**Anahtar Kelimeler:** yalın üretim, altı-sigma metodolojisi, TÖAİK, yalın altı sigma yaklaşımı, savunma sanayi

## ACKNOWLEDGEMENTS

I would like to express my special appreciation and thanks to my advisor Assistant Professor Dr. Benhür Satır, for being a tremendous mentor for me. I would like to thank you for encouraging my research. I would also thank for your advice on both research as well as on my career which are invaluable for me.

I would also like to thank my committee members, Assistant Professor Hakan Özaktaş and Associate Professor Hakan Çerçioğlu for serving as my committee members. I also want to thank you for letting my defense be an enjoyable moment, and for your brilliant comments and suggestions, thanks to you.

I would especially thank to Associate Professor Ferda Can Çetinkaya, for giving me the opportunity to complete my Master of Science degree, and for his close attention and relevance.

Special thanks to my mother, father and sister for their support all through my life. Words cannot express how grateful I am to my mother and father for all the sacrifices that they've made on my behalf. Your prayer for me, was what brought me this far.

From my hearth, very special thanks to my beloved wife Duygu, for supporting and encouraging me throughout this experience, and being with me for years and make me feel precious and unique.

**September 2019**

**Burak ALPER**

# TABLE OF CONTENTS

STATEMENT OF NON-PLAGIARISM PAGE .....	III
ABSTRACT .....	V
ÖZ .....	VI
ACKNOWLEDGEMENTS .....	VII
TABLE OF CONTENTS.....	VIII
LIST OF TABLES.....	XI
LIST OF FIGURES.....	XII
LIST OF ABBREVIATIONS.....	XIII
CHAPTER 1. INTRODUCTION.....	1
CHAPTER 2. LEAN MANUFACTURING .....	2
2.1. WHAT IS LEAN MANUFACTURING .....	2
2.2. THE HISTORY OF LEAN MANUFACTURING .....	2
2.3. PRINCIPLES OF LEAN MANUFACTURING.....	3
2.3.1. <i>Eight Basic Types of Waste</i> .....	3
2.3.1.1. Over Production .....	3
2.3.1.2. Waste of Motion .....	4
2.3.1.3. Waste of Inventory.....	4
2.3.1.4. Defective Production .....	5
2.3.1.5 Waste of Waiting.....	5
2.3.1.6 Waste of Transportation.....	6
2.3.1.7 Waste of Over-processing.....	6
2.3.1.8 Non-Utilizing Talent.....	7
2.4. TOOLS USED IN LEAN MANUFACTURING .....	7
2.4.1. <i>Value Stream Mapping (VSM)</i> .....	7
2.4.2. <i>Single Minute Exchange of Die (SMED)</i> .....	8
2.4.3. <i>Standardized Work</i> .....	9
2.4.4. <i>Poka-Yoke (Mistake Proofing)</i> .....	9
2.4.5. <i>The 5 S method</i> .....	10
2.4.6. <i>Jidoka (Autonomation)</i> .....	11
2.4.7. <i>Heijunka (Leveling)</i> .....	11

2.4.8. Kaizen Philosophy.....	12
2.4.9. Kanban .....	12
<b>CHAPTER 3. SIX-SIGMA METHODOLOGY .....</b>	<b>13</b>
3.1. WHAT IS SIX-SIGMA?.....	13
3.2. THE HISTORY AND MAJOR PERSPECTIVES OF SIX-SIGMA .....	14
3.2.1. History of six-sigma.....	14
3.2.2. Accuracy and Precision; The target analogy.....	15
3.2.3. Statistical Viewpoint of Six-sigma .....	16
3.2.4. Business Viewpoint of Six-sigma .....	20
3.3. THE SUCCESS CRITERIA OF SIX-SIGMA .....	20
3.3.1. Result-based Criteria .....	20
3.3.1.1. Criteria Based on Faulty Unit.....	20
3.3.1.2. Criteria Based on Error.....	21
3.3.1.3. Criteria Based on Error Probability .....	21
3.3.2. Process-based criteria .....	21
3.3.2.1. First Pass Success Rate.....	21
3.3.2.2. Total Process Success Rate.....	22
3.3.3. The Sigma Level.....	22
3.4 SIX-SIGMA DMAIC APPROACH.....	22
3.4.1. Definition of DMAIC.....	22
3.4.2. Phases of DMAIC.....	23
3.4.2.1. Define Phase .....	23
3.4.2.2. Measure Phase.....	24
3.4.2.3. Analyze Phase .....	25
3.4.2.4. Improve Phase .....	25
3.4.2.5. Control Phase.....	26
3.4.3 Tools used in DMAIC method.....	27
3.4.3.1. SIPOC Diagram .....	27
3.4.3.2. Critical-to Quality (CTQ) .....	28
3.4.3.3. CTQ Tree .....	28
3.4.3.4. Voice of Customer (VOC) .....	29
3.4.3.5. RACI Chart.....	30
3.4.3.6. Histogram .....	31
3.4.3.7 Normal Probability Curve.....	32
3.4.3.8 Flowchart .....	32
3.4.3.9 Pareto Chart.....	32
3.4.3.10 The 5-Why approach .....	33
3.4.3.11 Fishbone Diagram.....	34
3.4.3.12 Control Plan .....	35
3.4.3.13 Statistical Process Control (SPC).....	36

3.5. OPERATIONAL BENEFITS OF SIX-SIGMA .....	37
3.5.1. <i>Making the Organization Systems more Driven</i> .....	38
3.5.2. <i>Reduction of Personnel Time and Required Skill</i> .....	38
3.5.3. <i>Reduction of Wastage</i> .....	38
3.5.4. <i>Reduction of Inventory Needs</i> .....	38
3.5.5. <i>Reduction of Reworks and Defects</i> .....	39
3.5.6. <i>Increasing Customer Satisfaction</i> .....	39
3.6. ROLES AND RESPONSIBILITIES IN A SIX-SIGMA PROJECT .....	39
<b>CHAPTER 4. LEAN SIX-SIGMA APPROACH .....</b>	<b>41</b>
4.1. WHAT IS LEAN SIX-SIGMA? .....	41
4.2. FIVE ESSENTIALS OF LEAN SIX-SIGMA.....	42
4.2.1 <i>Customer Quality Needs</i> .....	42
4.2.2 <i>Flexibility</i> .....	42
4.2.3 <i>Focus (Pareto Rule)</i> .....	42
4.2.4 <i>Velocity</i> .....	43
4.2.5 <i>Complexity and Cost</i> .....	43
<b>CHAPTER 5. APPLICATION OF LEAN SIX-SIGMA .....</b>	<b>44</b>
5.1 COMPANY PROFILE .....	44
5.2. DEFINITION OF THE LEAN SIX-SIGMA PROJECT .....	45
5.3. STEPS FOLLOWED IN THE PROJECT .....	46
5.3.1. <i>Define Phase</i> .....	46
5.3.2. <i>Measure Phase</i> .....	49
5.3.3. <i>Analyze Phase</i> .....	50
5.3.4. <i>Improve Phase</i> .....	51
5.3.5. <i>Control Phase</i> .....	53
<b>CHAPTER 6. CONCLUSION.....</b>	<b>55</b>
<b>REFERENCES .....</b>	<b>56</b>
<b>APPENDICES .....</b>	<b>62</b>
<b>CURRICULUM VITAE .....</b>	<b>75</b>

## LIST OF TABLES

### TABLES

<b>Table 1: Sigma Level vs DPMO</b> .....	17
<b>Table 2: Long-term DPMO values [49,50]</b> .....	19
<b>Table 3: Some example of functional roles vs. six-sigma roles [11]</b> .....	40
<b>Table 4: Project Charter [45]</b> .....	47
<b>Table 5: Stakeholders of the Project [45]</b> .....	48
<b>Table 6: Data Collection Plan [45]</b> .....	49
<b>Table 7: Implementation Plan [45]</b> .....	52
<b>Table 8 : Comparison of measurements [45]</b> .....	54

## LIST OF FIGURES

### FIGURES

<b>Figure 1: Value Stream Map [46]</b> .....	7
<b>Figure 2: Accuracy &amp; Precision [41]</b> .....	16
<b>Figure 3: The 1,5-sigma shift [48]</b> .....	18
<b>Figure 4: SIPOC [44]</b> .....	27
<b>Figure 5: The CTQ Tree [42]</b> .....	28
<b>Figure 6: Voice of Customer [44]</b> .....	29
<b>Figure 7: Kano's Model [43]</b> .....	30
<b>Figure 8: RACI Chart Example [22]</b> .....	31
<b>Figure 9: Histogram [45]</b> .....	31
<b>Figure 10: Process Flowchart [44]</b> .....	32
<b>Figure 11: Pareto Chart [44]</b> .....	33
<b>Figure 12: 5-Why Method [44]</b> .....	34
<b>Figure 13: Fishbone Diagram [44]</b> .....	35
<b>Figure 14: Viewpoint differences between Lean &amp; Six-sigma [40]</b> .....	41
<b>Figure 15:SIPOC Diagram [45]</b> .....	47
<b>Figure 16: Process Map [45]</b> .....	48
<b>Figure 17: Fishbone Diagram of the Project [45]</b> .....	50
<b>Figure 18: 5 Why method used in the Project [45]</b> .....	50
<b>Figure 19: Implementation Difficulty Matrix [45]</b> .....	51
<b>Figure 20: Press brake die &amp; Bending Operation [51]</b> .....	53

## **LIST OF ABBREVIATIONS**

**LSS** : Lean Six-sigma

**DMAIC** : Define, Measure, Analyze, Improve, and Control

**SIPOC** : Suppliers, Input, Process, Output, Customers

**RACI** : Responsible, Accountable, Consulted, and Informed

**SMED** : Single Minute Exchange of Die

**5S** : Seiri, Seiton, Seiso, Seiketsu, Shitsuke

**DPMO** : Defect Per Million Opportunities

**TPS** : Toyota Production System

**SPC** : Statistical Process Control

**VOC** : Voice of Customer

**CTQ** : Critical to Quality

**WIP** : Work-in-process

**MBB** : Master Black Belt

**BB** : Black Belt

**GB** : Green Belt

**YB** : Yellow Belt

**OEE**: Overall Equipment Effectiveness

## **CHAPTER 1**

### **INTRODUCTION**

The fact that the producer societies in the world have a more prominent place than the consumer societies, especially in the years following the Industrial Revolution, has been instrumental in increasing the production. In order to increase production, more tools, equipment and manpower were used; In short, more investments were made.

With the lean six-sigma philosophy developed over time, it is seen that the reduction of losses in processes, is more beneficial than the investment on existing production facilities. With the development of relatively less costly improvements and the reduction of wasted resources in the current system, it is possible to ensure efficiency and thus to increase production both in number and quality.

In this thesis, an application done in an aviation and defense firm's press brake workstation will be explained. Among the tools that will be mentioned in the upcoming chapters, the ones that are selected by the project team have been used. To be more in control of the problem and handle the project more accurately, DMAIC approach from six-sigma methodology has been selected. Following the steps of DMAIC, the application has been finalized and at the end, the results obtained will be discussed.

## CHAPTER 2

### LEAN MANUFACTURING

#### 2.1. What is Lean Manufacturing

Over the past decades, there have been significant changes in manufacturing, marketing and business globally. The improvement of technology and information share triggered enormous changes overall industries and affected almost every sector all over the world. This brought also a challenge between countries and they began struggling to obtain the biggest part from the global market-share. In such a competition, some of the countries got one step ahead of others due to their manufacturing and quality approaches. Before the second world war, Germany had one of the most powerful industries around the globe. After the second world war, The United States and Japan had also developed good manufacturing systems and approaches resulting with powerful economies. The six-sigma approach developed by the United States (Motorola) was mentioned in the first chapter. In this chapter we will focus on Lean Manufacturing developed by Japan (Toyota).

#### 2.2. The History of Lean Manufacturing

“The evolution of production systems in the motor industry has been comprehensively changed as has the story of the Toyota Production System, which fueled one of the greatest corporate success stories “[23]. Taiichi Ohno analyzed Western production systems and he argued that they had two logical flaws “[23]. “First, he reasoned that producing components in large batches resulted in large inventories, which took up costly capital and warehouse space and resulted in a high number of defects. The

second flaw was the inability to accommodate consumer preferences for product diversity”[23]. Therefore “*Toyota’s production system can be called a hybrid system. It is because they implemented the Ford system used in the U.S, by changing some aspects to the domestic market.*” (page 50) [25].

### 2.3. Principles of Lean Manufacturing

As it is mentioned above, lean manufacturing was introduced by Taiichi Ohno, as an approach to reduce wastes in production. This was because Toyota had not a capability to make mass production such as Ford. Ohno focused on eliminating wastes and improve production rate with the usage of same resources, achieving a more efficient production rate within the company limits.

#### 2.3.1. Eight Basic Types of Waste

The name “lean” comes from the concept “eliminating wastes”. It is because of if you eliminate wastes and only spend your resources on what you need to produce, you produce the product simpler. Taiichi Ohno defined seven basic types of waste in a manufacturing system. After decades, a new waste named “non-utilizing talent” was introduced and the number of wastes increased to eight. In this section, these wastes will be discussed to better understand lean manufacturing principles.

##### 2.3.1.1. Over Production

Waste of production is considered the worst of the eight wastes of lean manufacturing. As lean manufacturing aims to work JIT, producing regardless of order increases excess inventory. This has three negative results. Firstly, you spend your resources to produce goods which you don’t know when you will be able to sell. So, you are spending your labor, raw materials, time and money although you have nothing in return. Secondly, you have the risk to miss opportunity to produce other goods in case

of an order comes and you have already spent one or more of your resources. Thirdly, the produced good causes inventory holding costs. “The mind set of continuing to build regardless of orders must change if a company is going to be successful implementing lean” [29].

#### 2.3.1.2. Waste of Motion

The main three actions defined in unnecessary motion are bending, reaching, lifting and movement. Reduction of bending and reaching may not only be beneficial ergonomically, it can help increase safety within the facility. When trying to reduce waste of motion, movements should be kept small wherever possible. Using arms and forearms should be selected instead of fully extending the arm to reach a part [29].

#### 2.3.1.3. Waste of Inventory

The crucial point of having excess inventory is that, it can hide many problems in our company. The main five basic inventories can be described as finished goods, sub-assembly, raw materials, office supplies and Maintenance / Repair and Operations / Overhaul (MRO) [29].

**Finished Goods Inventory:** “Very few repetitive manufacturing companies, if any, operate with zero finished goods inventory. Their customers expect immediate or next day delivery, so a marginal volume of inventory (at the very least) must be kept at the finished goods level”[29]. The key point is that the inventory level must be determined well and must be kept as low as possible.

**Sub-Assembly Inventory:** “Zero sub-assembly inventory should be the ultimate target; however, many companies will require some level of it. This inventory needs to be closely monitored in order to avoid consuming raw materials that may be required for other products”[29]. This will lead to other wastes. A Kanban system which will be discussed further will help keeping sub levels under control.

**Raw Materials Inventory:** Raw materials inventory is a little bit different than the others. This is because you must consider more variables, while determining the amount to keep in stock.” Firstly, keeping high levels of inventory to protect against expedite costs due to short ships, supplier issues and fluctuations in customer demand will be an advantage”[29]. Also buying in large quantities give opportunities to price breaks. On the other hand, your inventory holding cost increases and the cash flow levels increase. So, in this case all these pros and cons should be considered to determine the best level of inventory that should be kept.

**Office Supplies Inventory:** “Office supplies are often overlooked when considering inventory because they are not directly related to production”[29]. Carrying excess supplies will take up space and tie up cash. Therefore, elimination of office supplies inventory is also a topic to consider.

**MRO:** “This inventory should be tightly controlled, due to the critical situations that generally call. Unfortunately, the same critical nature that requires tight control also results in high MRO inventory”[29]. So, the best way to reduce this type of waste is developing a preventive maintenance plan.

#### 2.3.1.4. Defective Production

This type of waste can lead to rework, salvage and scrap within the company. “Because of this high-risk potential, waste of defects can be the costliest of all the wastes. It may cost to losing a customer, which will result in lost future sales”[29]. Quality must be built into the process when building the product. By doing this, defects can be eliminated, and a solid reputation based on quality products can be built, resulting with customer loyalty [29].

#### 2.3.1.5 Waste of Waiting

“Some of the forms of waiting can be detected easier when there are component shortages on a production line, or when a machine is down. Waste of waiting may be a little more difficult to notice within a process”[29]. In order to reduce component

shortages, if the shortage occurs within the company, using a Kanban system can be beneficial. If the shortage occurs outside the production system, then the usage of material planning methods would be a good choice to prevent component shortages. For the machine downtime case, a solid preventative maintenance program will help to reduce waste of waiting across the production line [29].

#### 2.3.1.6 Waste of Transportation

Moving product more than necessary, storing product in a temporary location and move it shortly thereafter and moving with empty delivery carts are all considered a very big waste. Application of standardized material handling routes will help reduce this waste. Transportation wastes occur mainly in production area, material delivery areas and supply chain. Using a Kanban system is crucial to eliminate wastes in transportation within the production and material delivery areas. Also, optimizing the transportation plays a key role in supply chain and wastes could be eliminated this way [29].

#### 2.3.1.7 Waste of Over-processing

“The first considerations when looking to eliminate waste of over-processing are whether the work is necessary and/or if it adds value to the final product”[29]. When focusing on eliminating waste of over-processing, looking for better methods to produce a product or perform a service is very important. In the end, if there’s a better more efficient method for getting the same or better results, investigating it and implementing it if it’s feasible are the keys to eliminate waste of Over-processing [29].



“The elements of VSM include customer loop, production control, supplier loop, manufacturing loop, information flow and lead time data bar with critical path that make us have a full view of the whole supply chain from customer’s requirements to supplier’s delivery. Value stream mapping helps us understand where we are (Current State), where we want to go (Future State) and map a route to get there (Implementation Plan), which can create a high-level look at total efficiency”[30].

#### 2.4.2. Single Minute Exchange of Die (SMED)

“SMED is one of the many lean production methods for reducing waste in a manufacturing process. It provides a rapid and efficient way of converting a manufacturing process from running the current product to running the next product. This rapid changeover is key to reducing production lot sizes and thereby improving flow. The phrase single minute does not mean that all changeovers and startups should take only one minute, but that they should take less than 10 minutes (in other words, single-digit minute)” [32].

“Setup operation is defined as the preparation or post adjustment that is performed once before and once after each lot is processed. SMED was originally developed to improve die press and machine tool setups, but its principles apply to changeovers in all type of processes. Setup operation is defined as the preparation or post adjustment that is performed once before and once after each lot is processed” [31].

“Shingo divides the setup operation into two parts:

**Internal setup:** The setup operation that can be done only when the machine is shut down (attaching or removing the dies).

**External setup:** The setup operation that can be done when the machine is still running.

These operations can be performed either before or after the machine is shut down; for example, getting the equipment ready for the setup operation can be done before the machine is shutdown” [32].

The three main steps of SMED, can be summarized as follows:

Step 1: Separating internal and external setup

Step 2: Converting internal setup to external setup

Step3: Streamlining all aspects of the setup operation

The reduction of setup time usually provides many benefits to the companies, e.g., reductions in terms of stock, WIP, batch size and movements, and, improvements on quality and production flexibility [33].

#### 2.4.3. Standardized Work

“Standardized work is a tool used Lean Manufacturing for the improvement of work and improves the sustainability of production processes” [35]. “Standardization means uniformly operations, or tasks by all operators. Standardized Work is the best method of operation. This allows the exercise of all steps in the same way, in the same order and time, at a fixed cost. Standardization also assumes continuous development of new, better standards, so as to adapt to the constantly changing customer requirements” [34].

#### 2.4.4. Poka-Yoke (Mistake Proofing)

Poka-Yoke “is a method of preventing errors coming from mistakes. The main principle in the system Poka-Yoke is that the errors are to blame processes, not the employees. Poka-Yoke solution is characterized to prevent any errors in the process. With Poka-Yoke it is also possible to obtain reduced time required for training

employees, eliminating many quality control operations (or its total elimination), reducing the number of defects and a 100% control of the process” [34].

#### 2.4.5. The 5 S method

5S “is the basis for the implementation of Lean Manufacturing. The method name is derived from the first letters of the Japanese words: Seiri, Seiton, Seiso, Seiketsu, Shitsuke. They are also the names of the five stages of organization of the work” [35];

##### **Seiri** (sorting, selection)

“The elimination of the workstation of all the items that are unnecessary to do the job. Step is carried primarily of decreased inventory, and better use of working space. In accordance with the principle of selection, all unnecessary items should be marked with a red label and placed in a designated area” [34].

##### **Seiton** (systematics)

“The arrangement, designation and selecting a suitable place for all tools in the workstation at the selection stage. It can help in this instance. board of shadows or color coding each tool. Step is performed to reduce unnecessary traffic employee performed when searching for tools and elimination of errors the quality of products resulting from mistakes by properly marking items” [34].

##### **Seiso** (cleaning)

“The cleaning and maintenance of the workplace and sets out the standard of proper cleaning. Stage aims to: maintain positions in good condition, identify and eliminate the causes of pollution and care of machines” [34].

### **Seiketsu** (standardize)

“To determine the rules for the first three stages of 5S. In this stage, mainly defines the responsibilities of employees and creates instructions, supporting the execution of the previous steps. Stage provides a systematic procedure and repeatability previously entered changes” [34].

### **Shitsuke** (discipline)

“The ratcheting up at the habits of employees to comply with the previously introduced changes and act in accordance with the standards. It is a difficult and long stage, because it forces you to change the habits of both production workers and management” [34].

#### 2.4.6. Jidoka (Autonomation)

The “notion of Jidoka refers to the ability to stop the production line or machine by the operator at the time of the appearance of a malfunction or problems during manufacture. Problems may be related to the quality of products and delays the manufacturing process due to a lack of material, tool information. Equipment operators the ability to detect emerging anomalies and immediately stop the operation, it allows for a more efficient production process. Tools that enable the implementation of the rules Jidoka are: Poka-Yoke and Andon” [36].

#### 2.4.7. Heijunka (Leveling)

“Heijunka, or leveling production is mainly aimed at eliminating jumps in production. Leveling production is known as a method of sequencing products in order to balance the production, increase productivity and flexibility by eliminating waste and minimizing differences in load workstations “[37]. “Production leveling consists in determination of the sequence and the amount of flow from the process, so that current demand was realized from the warehouse / supermarket and did not cause sudden

changes in the production schedule. Production schedule should be in a given period of time constant (time largely depends on the seasonality of products). The aim is to ensure that the products were produced in a sequence in batches of as few pieces. In other words, production leveling is a way of ensuring the availability of products for customers through a repeatable and uniform flow of products and supplies in the warehouse. Repeatable flow of products from production also contributes to load balancing workstations “[34].

#### 2.4.8. Kaizen Philosophy

“Kaizen philosophy is the concept of continuous improvement, which assumes constant search for ideas to improve all areas of the organization. It requires the involvement of all the company's employees, operators, up to the highest level of management” [34]. “The aim of Kaizen is permanently replacing waste activities adding value. In practice Kaizen comes to collecting and implementing ideas of employees, which serve to improve the organization of work, or improving the production process” [39].

#### 2.4.9. Kanban

Kanban “is a Japanese method of production control, which assumes control not based of the production schedule, and through events occurring directly on production. The use of Kanban allows for almost total elimination of pre-magazines (the stock is on the workstation), interoperable, and finished products. The raw materials are delivered from suppliers with hourly precision, , and thanks to reserves, production capacity and flexibility of the production process it is possible to produce almost any product at any time. In contrast, production orders are closely synchronized with orders received from customers” [37].

## CHAPTER 3

### SIX-SIGMA METHODOLOGY

#### 3.1. What is six-sigma?

Six-sigma methodology has been used since the 1980's in the manufacturing industry and nowadays it is also used in different areas of business. Although there is not a specific definition, it can be thought as both a philosophy and a methodology. Different authors define Six-sigma as;

*“Six-sigma is a systematic, highly disciplined, customer-centric, and profit-driven organization-wide strategic business improvement initiative that is based on a rigorous process focused and data-driven methodology”* [1].

*“Six-sigma is a project-driven method aimed at sustainable business performance improvement. It focuses on better understanding of changing customer requirements, improving processes throughout the organization, and enhancing the organization's financial performance”* [2].

*“Six-sigma represents a statistical measure and a management philosophy that teaches employees how to improve the way they do business, scientifically and fundamentally, and how to maintain their new performance level. It gives discipline, structure, and a foundation for solid decision-making based on simple statistics”* [3].

According to the Six-sigma Institute; “Six-sigma is a defined and disciplined business methodology to increase customer satisfaction and profitability by streamlining operations, improving quality and eliminating defects in every organization wide process. Six-sigma Methodology can be used as a business strategy, a vision, a

benchmark, a goal, a statistical measure and a robust methodology. The Six-sigma Institute explains these six usage areas as follows” [11];

### 3.2. The History and Major Perspectives of six-sigma

There are two major perspectives of the Six-sigma Methodology which are the statistical and business viewpoints respectively. The origin of six-sigma comes from statistics and statisticians. So, the statistical viewpoint is more focused on measurability of the process. According to understand the lean six-sigma concept, it is essential to have information where it came from.

#### 3.2.1. History of six-sigma

The basis of the story shows us how Six-sigma applications change the way multinational companies operate worldwide. All started at 1981. After the World War 2, the Japanese made a quality initiative to produce products with higher quality, and lower costs. This approach was a threat to most American companies just like Motorola. Because of undercutting prices and increasing quality would have an impact on market shares. Motorola made the first attempt to answer back. They gathered all the top engineers in the company and formed a team which had only one purpose; researching all known quality tools and best practices used up to that time and combine them to construct an aggregated quality approach that will be the backbone of Motorola's quality improvement program. Motorola had already a quality notion, but they had more way to go to compete against the Japanese because to achieve same results they had to make a quality improvement of 10 to 1 in a five-year horizon. Motorola achieved their goal but although they made a quality improvement of 1000%, the Japanese were ahead again because of their previous lead. The management initiated the second program again with a goal of 1000% improvement. This time the duration was two years. Motorola again was successful achieving the goal. They continued by launching the third program again with the same goal but this time although some individual units achieved the goal, the overall achievement was 800%.

At the end of all three programs in 1991, Motorola had an impressive improvement about 800 to 1, which they defeated the Japanese in manner of quality. This made all other firms embrace six-sigma methodology as their main pillar by building their quality improvement plans.

### 3.2.2. Accuracy and Precision; The target analogy

A target analogy can be used to describe the difference between accuracy and precision. In this analogy, repeated measurements can be considered as arrows thrown at a target (Figure 2). Accuracy corresponds to the proximity of the arrows to the center of the target. The arrows that hit the target close to the center are considered more accurate. “The closer the values obtained by a measuring system are, to the accepted value, the more accurate the system is” [13].

If multiple arrows are thrown, the width of the set of stuck arrows are corresponding to precision. If all arrows are firmly in place, the group is “*precise*” because they are all stuck close to the same point, even if it is not the center of the target. “In this case the measurements are precise but may not be accurate” [13].

“However, it is not possible to obtain accuracy without precision. If the arrows do not form a close block, they cannot all be close to the target center. The average positions may be an accurate estimate of the target center, but the arrows are incorrect one by one alone” [13].

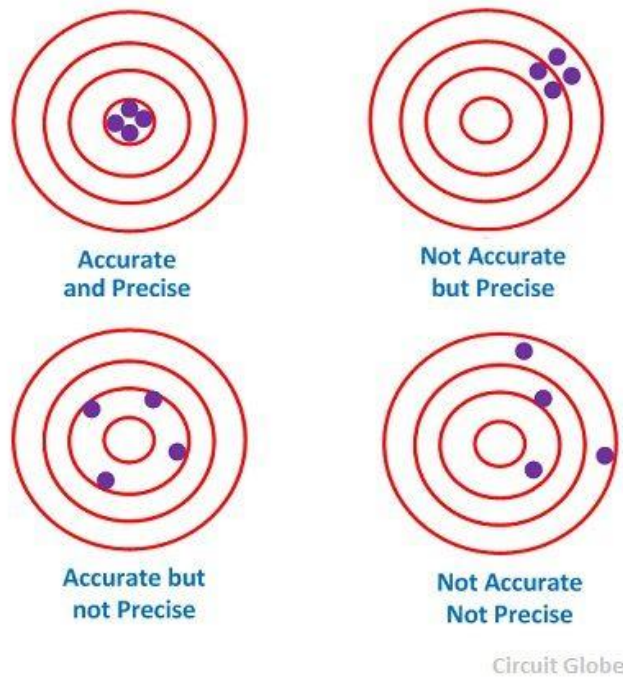

Figure 2: Accuracy & Precision [41]

### 3.2.3. Statistical Viewpoint of Six-sigma

“The accuracy of a measurement system can be defined as the degree of proximity of a quantity to its real value in engineering, industry and statistics. The precision (also called repeatability) of a measuring system can be defined as the degree of measurements under the same conditions give the same result” [13].

“Although two terms may be synonymous in everyday language, in the scientific method they are used separately. A measuring system may be accurate but not precise, precise but not accurate, can be both, or not both. For example, if there is a systematic error in an experiment, increasing the sample size generally increases precision but does not improve accuracy. Eliminating systematic errors improves accuracy but does not increase precision”[13].

If a measuring system is both accurate and precise, it is called “*valid*”. The directional effect caused by an element or elements that are not associated with an independent variable is called “*bias*”. Another related term “*error*” is defined as random variability.

From the statistical point of view, the main aim of six-sigma is to reduce the total number of defects below 3.4 per million parts/opportunities. This gives us a success rate of 99.99%. Here the term sigma is used to denote the variation about the process average [4].

*Table 1: Sigma Level vs DPMO*

Sigma Level ( $\sigma$ )	Defects per Million Opportunities (DPMO)	Success Rate
2 $\sigma$	308,537	62.9%
3 $\sigma$	66,807	93.3%
4 $\sigma$	6,210	99.4%
5 $\sigma$	233	99.98%
6 $\sigma$	3.4	99.9997%

Sigma ( $\sigma$ ), Greek letter that is the statistical representation of Standard Deviation, measures how far a given process deviates from perfection. The central idea behind six-sigma is that if the number of “defects” can be measured in a process, then they can be eliminated by systematically figuring out how to get as close to "zero defects" as possible [5]. Therefore, the six-sigma method is a very rigorous quality control concept where many organizations still performs at three sigma level [6].

Statistically, Six-sigma refers to a process in which the range between the mean of a process quality measurement and the nearest specification limit is at least six times the standard deviation of the process where sigma is a term used to represent the variation about the process average (Table.1). The statistical objectives of Six-sigma are to center the process on the target and reduce process variation [7].

The statistical theory of variation for Six-sigma is based on the supposition that all things, when measured fine enough, vary and that is called “natural variation.” Six-sigma emphasizes identifying and avoiding variation. But what also makes Six-sigma unique is the explicit recognition of the correlation among the number of product defects, wasted operating costs, and the level of customer satisfaction [8].

Today almost everyone has heard about six-sigma. Although they know it is a methodology to make improvements especially in increasing quality, why is the name

six-sigma process? Where does this name come from? It expresses the difference (in other words deviation) between the mean and the nearest specification limit. The aim here is to detect how many items fall outside the validation area, meaning they fail [47].

This is used in process capability, which measure the number of standard deviations between the mean and the nearest specification limit, in terms of sigma units. “As the standard deviation of a process increases, or the mean moves from the center of the tolerance, fewer items will fit into the limits. This decreases the sigma number and increases the likelihood of items outside the limits”[47].

Another important fact to know in six-sigma is the 1,5-sigma shift. The process can drive accurate solutions in short term, but in long term where more and more data are entered to the process, the number of sigma that will fit between the mean and specification limit will drop over time, if compared to a short-term process. So, in order to handle this increase in process variation (which is totally normal in real life), an empirical 1,5-sigma shift is added to the calculation.

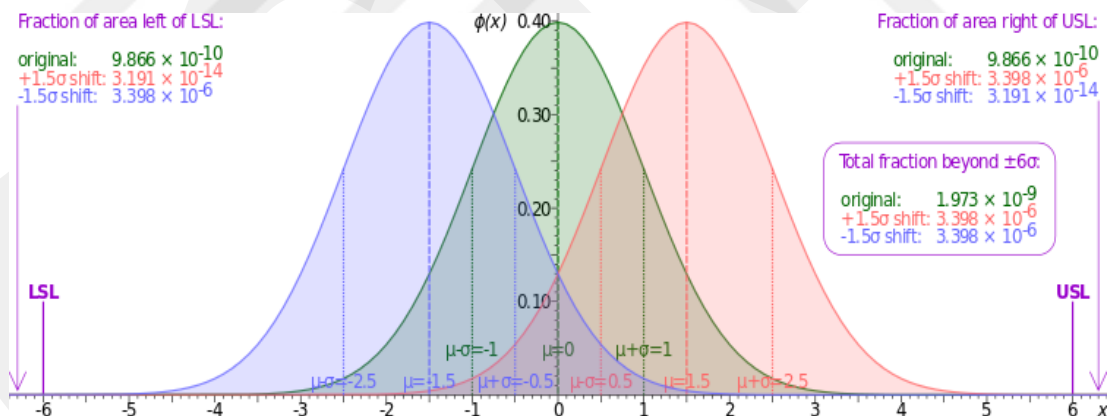

Figure 3: The 1,5-sigma shift [48]

The idea behind this adjustment is that, a process which fits 6 sigma between the limits in short term, can only fit 4,5 sigma in the long term (figure 3). There can be two reasons for this; one is that the mean can move over time, another reason could be that the standard deviation in long term can be greater than the standard deviation observed in the short term.

The six-sigma process is to be known as a process that produces 3.4 defective parts per million opportunities (DPMO). “This is based on the idea of a normally distributed data will have 3.4 parts outside the limits (say defective) of one million parts, when the nearest specification limit will be 6 sigma far from the original mean, when the mean is shifted by 1.5 sigma” [47].

As Tennant (2001) explains; “The former six-sigma distribution, when under the effect of the 1.5 sigma shift, is commonly referred to as a 4.5 sigma process. The failure rate of a six-sigma distribution with the mean shifted 1.5 sigma is not equivalent to the failure rate of a 4.5 sigma process with the mean centered on zero.<sup>[3]</sup> This allows for the fact that special causes may result in a deterioration in process performance over time and is designed to prevent underestimation of the defect levels likely to be encountered in real-life operation” [47]. Table 2 below gives long-term DPMO values corresponding to various short-time sigma levels [49,50]. As it can be seen in the table, without the 1.5  $\sigma$  shift, the result for 6 sigma level is 0.0019 defects per million, in other words 2 defects per billion. Comparing this number with 3.4 ppm, which is the value with six sigma under shift, the underestimation of the defect levels in real life applications can clearly be seen.

*Table 2: Long-term DPMO values corresponding to short-time  $\sigma$  levels [49,50]*

Sigma Level	Sigma Level without shift		With 1.5 $\sigma$ shift		
	<u>DPMO</u>	Percentage yield	Long term Sigma Level	<u>DPMO</u>	Percentage yield
1	317,310	68.269%	-0.5	691,462	31%
2	45,500	95.450%	0.5	308,538	69%
3	2,699	99.730%	1.5	66,807	93.3%
4	63	99.994%	2.5	6,210	99.38%
5	0.5	99.999943%	3.5	233	99.977%
6	0.0019	99.9999998%	<b>4.5</b>	<b>3.4</b>	<b>99.99966%</b>
7	0.00000256	99.9999999997%	5.5	0.019	99.9999981%

### 3.2.4. Business Viewpoint of Six-sigma

“Six-sigma is a data-driven process improvement methodology used to achieve stable and predictable process results by reducing process variations and defects. Six-sigma is defined as ‘a business strategy that seeks to identify and eliminate causes of errors or defects or failures in business processes by focusing on outputs that are critical to customers’” [9].

“The six-sigma approach was first applied in manufacturing operations and rapidly expanded to different functional areas such as marketing, engineering, purchasing, servicing, and administrative support. The widespread applications of six-sigma were possible since organizations were able to articulate the benefits of six-sigma presented in financial returns by linking process improvement with cost savings” [12].

### 3.3. The Success Criteria of Six-sigma

The success criteria of sigma can be divided into two; result-based criteria and process-based criteria. These criteria have different sub criteria which are measured by focusing different aspects of production [5, 15]. You can see the calculations for each criterion in the subsections below;

#### 3.3.1. Result-based Criteria

These measures are based on the criteria taken from the end of the process and focus on effectiveness.

##### 3.3.1.1. Criteria Based on Faulty Unit

$$\text{Defective Part Rate} = \frac{\text{Number of defective parts}}{\text{Total number of produced parts}}$$

$$\text{Final Success Rate} = 1 - \text{Defective Part Rate}$$

### 3.3.1.2. Criteria Based on Error

$$\text{Error Rate Per Piece} = \frac{\text{Number of Errors}}{\text{Total number of produced parts}}$$

### 3.3.1.3. Criteria Based on Error Probability

$$\text{Number of Defects Per Opportunities} = \frac{\text{Number of Errors}}{\text{Number of Error Probability}}$$

$$\text{Defects Per Million Opportunities (DPMO)} = \frac{\text{Total Defects Observed}}{\text{Total Number of Opportunities}} \times 1.000.000$$

These criteria indicate whether customer needs are met but does not give exact information about how the process goes on. In other words; we cannot obtain enough information about the effectiveness of the process.

### 3.3.2. Process-based criteria

These measures are process based and focus on the effectiveness of each process.

#### 3.3.2.1. First Pass Success Rate

This criterion measures the ability of producing non-defective parts of the process.

$$\text{First Pass Success Rate} = 1 - \frac{\text{Number of Defective or Rework Requiring Parts}}{\text{Total Number of Input}}$$

### 3.3.2.2. Total Process Success Rate

If the process consists of more than one step, and the first pass success rate can be calculated for each step, the Total Process Success Rate is the cumulative product of the first pass success rates of each step.

### 3.3.3. The Sigma Level

As it is mentioned above in section 3.3.1.3, the calculated “*Defects Per Million Opportunities*” show us the number of defects in 1.000.000 parts produced. This DPMO number corresponds to a sigma level and is converted by the table(1) shown in section 3.2.2. before. As it was implied before, the 6-sigma level indicates that there is a probability of only 3,4 defects in 1.000.000 parts. Today, many industrial organizations can achieve these low defect rates [15].

## 3.4 Six-sigma DMAIC Approach

DMAIC can be considered as the roadmap of six-sigma. This roadmap shows the steps to follow in order to successfully complete a six-sigma project. Applying DMAIC properly is crucial to go step by step through the phases of the project.

### 3.4.1. Definition of DMAIC

DMAIC (Define, Measure, Analyze, Improve, and Control) refers to a data-driven life-cycle approach to Six-sigma projects for improving process; it is an essential part of a company's Six-sigma program. DMAIC is an acronym for five interconnected phases: define, measure, analyze, improve and control [17].

“Besides its role structure and focus on metrics, Six-sigma’s structured improvement procedure is seen as a novel and effective contribution to quality management. One

aspect of a scientific evaluation of Six-sigma is to critically compare its principles with insights from established scientific theories” [14].

### 3.4.2. Phases of DMAIC

As it is explained above, the DMAIC approach consists of five main phases; define, measure, analyze, improve and control. The subsections below look at these phases in detail.

#### 3.4.2.1. Define Phase

The define phase is the first phase of Lean Six-sigma improvement process. In this phase, the problem is defined by the project team by creating a “*Project Charter*”. A project charter is a map of the process and the main aim is to understand the needs of the customer in that project. Here customers may refer to individual people, as well as some teams or departments within an organization. Mainly they can be considered as whoever benefits from or uses the results of that project [20].

The first thing to do is to assemble a project team and assign a black or green belt to lead the team, and a sponsor or champion to the leadership of the project. Then the goal statement should be clearly defined. This statement defines when the team and project will be considered successful, in terms of quantitative results. The tools used in this phase are;

- SIPOC (Suppliers, Input, Process, Output, Customers)
- VSM (Value Stream Map)
- VOC (Voice of Customer)

De Koning & De Mast mention about four main statements to accomplish in this phase which are [19];

D1. Identify and map relevant processes.

D2. Identify stakeholders.

D3. Determine and prioritize customer needs and requirements.

D4. Make a business case for the project.

#### 3.4.2.2. Measure Phase

The measure phase focuses on measuring the magnitude of the problem in terms of lead time or quality. Measurement is critical throughout the life of the project because the project team must measure the improvement among the project. Firstly, measures should be done to know how the process is initially performing. According to this information, the project can be evaluated as it goes on. In this phase, how the process currently performs is determined, a plan is created to collect the data, the reliability of the data is ensured, the baseline data is gathered and finally the project charter is updated [20].

According to De Koning & De Mast; “in this phase the main goal is to translate the problem into a measurable form, measure the current situation, and refine the definition of objectives. The five main statements to accomplish in this phase are” [19];

M1. Select one or more CTQs (Critical-to-Quality)

M2. Determine operational definitions for CTQs and requirements.

M3. Validate measurement systems of the CTQs.

M4. Assess the current process capability.

M5. Define objectives.

### 3.4.2.3. Analyze Phase

The analyze phase is the part where the team should focus on the potential root causes of the problem. In order to make this, starting with a brainstorming session and develop hypotheses why these problems exist is the starting point. After that, the team should work to check whether their hypotheses are right or wrong. Verification includes both process analysis and data analysis and must be completed before implementing solutions [20].

In this phase firstly the process is closely examined, and data is graphically displayed. Secondly the cause or causes of the problem are verified and the project charter is updated. Here, the tools mainly used are;

- Histograms
- Pareto Charts
- Box Plots
- Fishbone Diagram (Ichikawa Diagram)
- 5 Whys

De Koning & De Mast [19] imply that “in the analyze phase, the influence factors and causes that determine the CTQs' behavior are identified. There are two statements to accomplish in this phase” [19];

A1. Identify potential influence factors.

A2. Select the vital few influence factors.

### 3.4.2.4. Improve Phase

The improve phase is the part where the project team is developing solutions to the root cause or causes. Here they pilot process changes and collect data to measure the improvement. In this phase teams usually use a technique to draw solutions such as; cross-training, setup reductions and Kanban. After selecting the practical solution, they develop maps of processes based on different solutions. The selection of the best

solution takes place in this phase, followed by the implementation of the selected solution. In the implementation part, planning is very crucial. So, they have to construct a good “Implementation Plan”, by considering logistics, training, documentation and communication plans. Here the team may use mini-testing cycles known as PDCA (Plan-Do-Check-Act) [20].

De Koning & De Mast [19] say that this phase is where “*Design and implementation of adjustments to the process to improve the performance of the CTQs*” [19] takes place. This is maintained by doing the following three steps;

- I1. Quantify relationships between X’s and CTQs.
- I2. Design actions to modify the process or settings of influence factors in such a way that the CTQs are optimized.
- I3. Conduct pilot test of improvement actions.

#### 3.4.2.5. Control Phase

The control phase is the phase where the problem has already been fixed or an improvement is sustained, and the team must create a “*Monitoring Plan*” in order to continue measuring the success of the updated process and develop a “*Response Plan*” in case there is a dip in performance. Here the project team must ensure that the process is properly managed and monitored using Control Plan, Control Chart and Monitoring & Response Plan. At this point, the team updates their documentation. One of the most powerful methods of ensuring others follow the new process is to create a visual workspace. This means that anyone can see at a glance exactly how a process flows and where to find what they need [20].

According to De Koning & De Mast (2006) ; “here the empirical verification of the project’s results and adjustment of the process management and control system takes place, in order that improvements are sustainable. In this phase the following two steps take place” [19];

- C1. Determine the new process capability.
- C2. Implement control plans.

### 3.4.3 Tools used in DMAIC method

As mentioned in the phases of DMAIC, there are several tools that are used in this process. In this subsection the most commonly used tools will be explained.

#### 3.4.3.1. SIPOC Diagram

The acronym SIPOC stands for Suppliers, Inputs, Processes, Outputs, and Customers for a given process. This diagram can map either a large or a small process according to the project. Some large projects might have many processes therefore a high level SIPOC can map the allover project, whereas low level SIPOC's can map each major process under it (Figure 4).

There are six main steps in order to construct a SIPOC Diagram which are;

- a. Listing the beginning and end of the process in the Processes column.
- b. Listing the major process steps from beginning to end points in the Process column.
- c. Listing the major Outputs from the processes listed in the center.
- d. Listing the Customers who receive the Outputs.
- e. Listing the inputs that are necessary for the Processes column.
- f. Listing the Suppliers who provide the inputs.

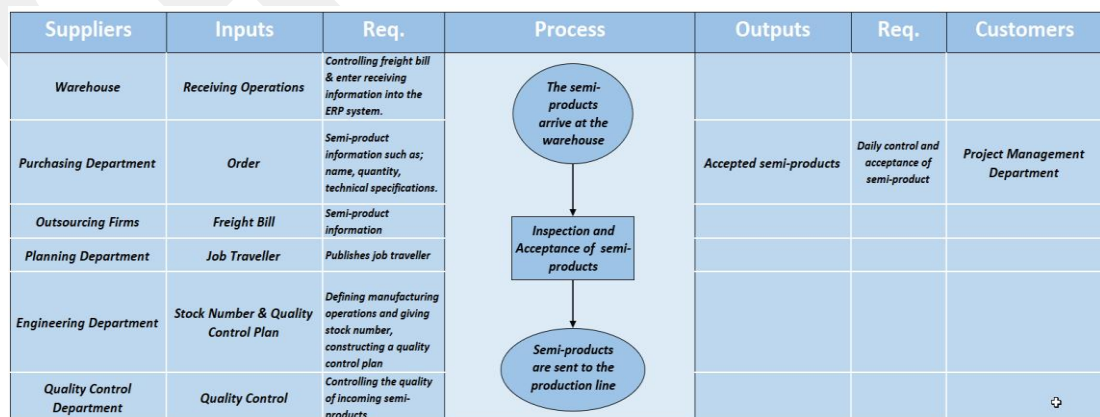

Figure 4: SIPOC [44]

### 3.4.3.2. Critical-to Quality (CTQ)

Critical to Quality (CTQ) is a process characteristic or component that has a direct effect on whether the overall process or product is perceived by the customer to be of acceptable quality. Identification of specific, measurable critical quality (CTQ) characteristics is essential for meaningful and measurable business process improvement. Data quality is an important consideration in the design effort. From a project perspective; it could result in project delays and impairment of testing. The project team needs to assure that data associated with their designs is both accurate and complete, by defining CTQ's for data quality [21].

### 3.4.3.3. CTQ Tree

As mentioned above, the acronym CTQ stands for Critical to Quality. These are parameters that define the problem, in other words the requirements of the customers. They are very crucial while developing a product or service. The importance comes from the purpose of satisfying customer needs. There are four main steps of drawing a CTQ Tree (Figure 5).

Firstly, the Voice of Customer (VOC) is identified. Secondly, the customer requirement parameters should be clearly understood. Thirdly, the parameters should be prioritized, and lastly the customer requirements should be converted into measurable CTQs.

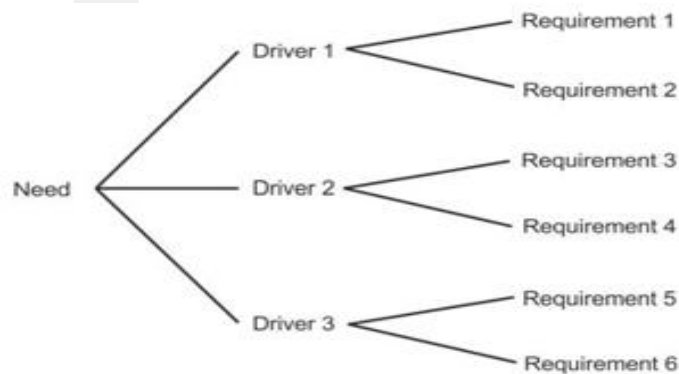

*Figure 5: The CTQ Tree [42]*

### 3.4.3.4. Voice of Customer (VOC)

The first thing is to define the target customers for the project, the project team must gather information about the customers' requirements. This process begins with defining the customers and then collecting data related to them. The VOC can be thought as what the customer tells about the quality and satisfaction of their needs. This information gives an idea about what the customer expects. So, it is a good measure of where we are now, and to what level we must improve the process. This step clearly needs an interaction with the customers (Figure 6).

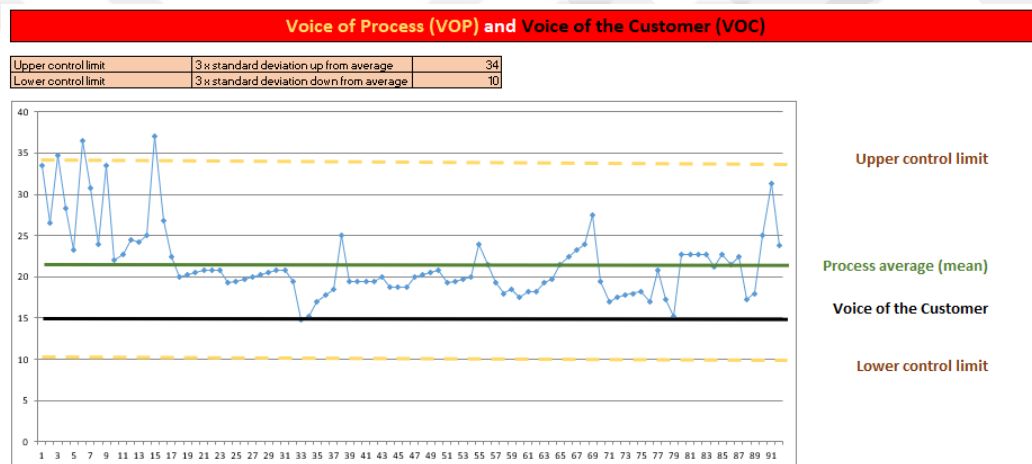

*Figure 6: Voice of Customer [44]*

After collection of the data, prioritization takes place. The needs of the customer can be divided into two features like; “need to have” and “nice to have”. The team can identify these features using the “Kano’s Model” (Figure 7).

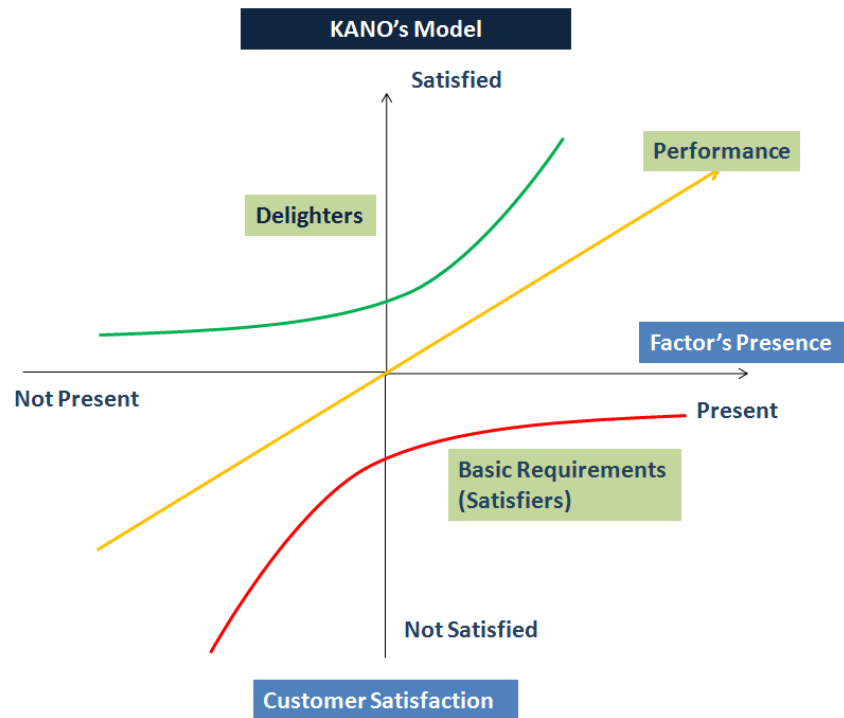

Figure 7: Kano's Model [43]

#### 3.4.3.5. RACI Chart

To be successful in a project, defining the roles and responsibilities of each team member is important. A RACI (Responsible-Accountable-Consulted-Informed) chart is used for this purpose. The chart consists of rows listing job titles or functions across the top, and columns for responsibilities or tasks (Figure 8). The following four terms define the roles of each member in the chart [22];

- a. **Responsible:** the person responsible for completing a given task.
- b. **Accountable:** the person to makes sure the work gets done, and/or that the right decision gets made.
- c. **Consulted:** one or more people who must be consulted with, prior to a given task being completed.
- d. **Informed:** one or more people who must be informed after a task is completed or a decision is made.

Deliverable or Task	Status	ROLES													
		Sponsor	Name or Role	Name or Role	Name or Role	Name or Role	Project Manager	Technical Lead	Name or Role	Name or Role	Name or Role	Consultant	Name or Role	Name or Role	Name or Role
		Sponsor / Leadership					Project Team					Other Resources			
<b>Phase 1</b>															
Deliverable/Task 1		A	R				I								
Deliverable/Task 2		A		R			I								
<b>Phase 2</b>															
Deliverable/Task 1		C	I				A	R							
Deliverable/Task 2			I				A		R						
<b>Phase 3</b>															
Deliverable/Task 1			I				A	I		R		C			
Deliverable/Task 2			I				A	I	R			C			
<b>Phase 4</b>															
Deliverable/Task 1				I			A	R					C		
Deliverable/Task 2				I			A		R						
<i>Insert new rows above this one</i>															

<b>R</b> Responsible	Assigned to complete the task or deliverable.
<b>A</b> Accountable	Has final decision-making authority and accountability for completion. Only 1 per task.
<b>C</b> Consulted	An adviser, stakeholder, or subject matter expert who is consulted before a decision or action.
<b>I</b> Informed	Must be informed after a decision or action.

Figure 8: RACI Chart Example [22]

### 3.4.3.6. Histogram

Histograms are used for visualizing process capability. The height of each bar on a histogram shows how often a given range of values occurs in the data set. Histograms can be made either manually or using a software like Minitab, one of the most commonly used software among statisticians and engineers (Figure 9).

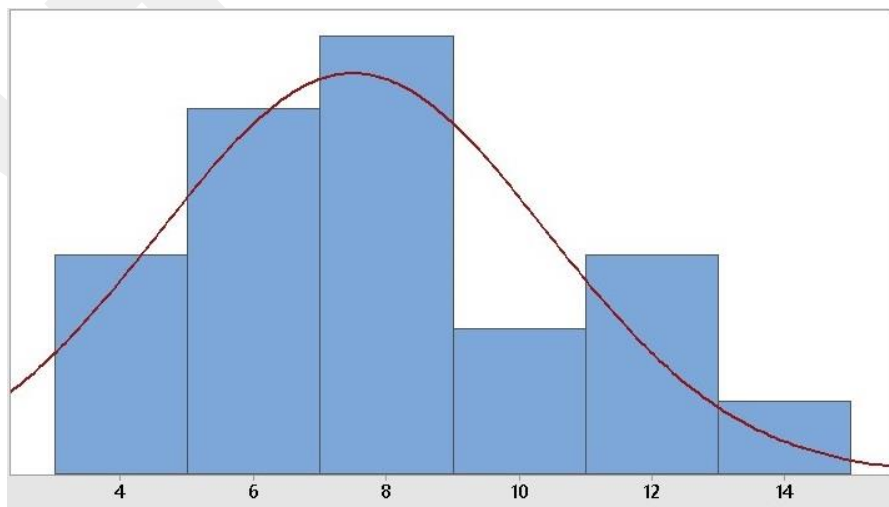

Figure 9: Histogram [45]

### 3.4.3.7 Normal Probability Curve

A normal probability curve shows the theoretical shape of a normally distributed histogram. The shape of the normal probability curve is based mean and standard deviation (Figure 9). The 3.4 DPMO rate used in six-sigma processes is based on the normal distribution curve.

### 3.4.3.8 Flowchart

Developing a flowchart is important in DMAIC process (Figure 10). As not all the team members might be familiar with the processes to be improved, it is important to use a flowchart in order to understand the process for them. SIPOC is a way to representing the same data but using flowchart can be easier to understand via its virtual function. Also, SIPOC is used more commonly in a higher level.

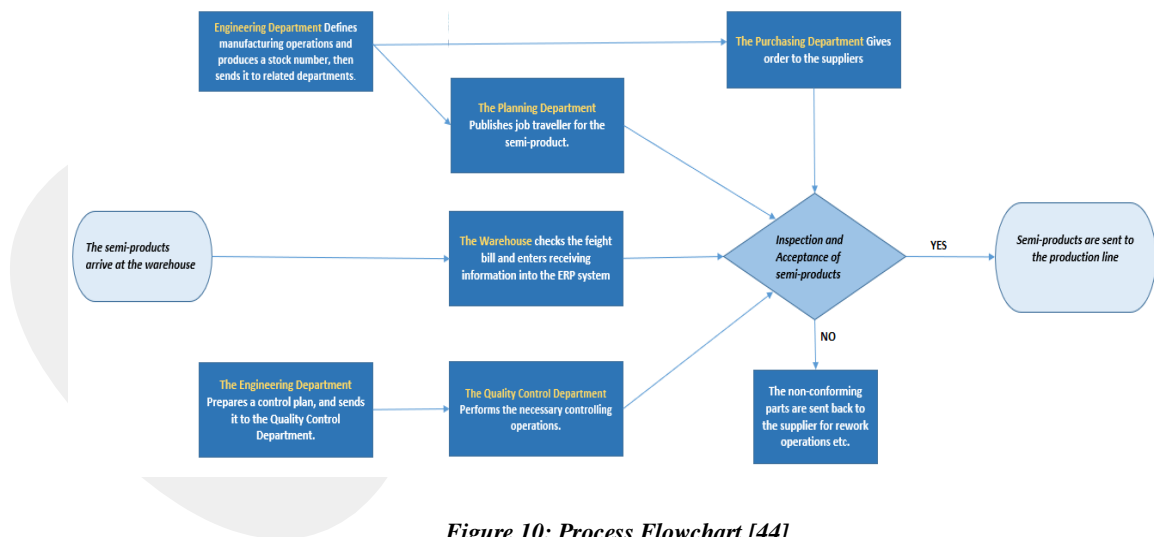
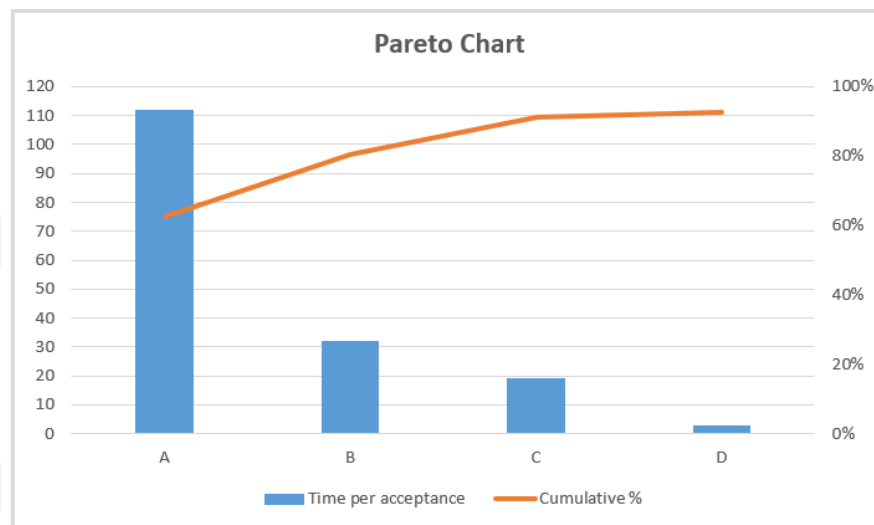

Figure 10: Process Flowchart [44]

### 3.4.3.9 Pareto Chart

A Pareto chart is a chart that is associated and commonly known as the 80/20 rule or the “Pareto Principle”. This rule implies that the 80% effect is made by the 20% of

the factors. For example, the 80% of the money in a bank, belongs to 20% of the customers. This rule is thought to be true in every case of life. The pareto chart is used to determine the factors that have the most impact on overall performance indicators such as defect-rate, service level or quality. So, in six-sigma projects, the pareto chart is used to be able to focus on the right indicators to achieve the most significant improvement. In most of the projects, there are two or three factors that influence the outcomes most. So, focusing on these factors and improving the process, ends more likely with an overall improvement of 80% (Figure 11).



*Figure 11: Pareto Chart [44]*

#### 3.4.3.10 The 5-Why approach

One of the simplest approaches to define root-causes in a six-sigma project is the 5-Why approach. This approach helps the project team to focus on the root causes rather on the symptoms. The main idea is to ask the question “Why?” to the problem statement. After getting the answer to the statement, again the question “Why?” is asked. This is repeated until no new answers can be obtained (Figure 12). The last answer developed implies the root-cause of the problem related to that process. After determining the root-causes, the team focuses on eliminating these causes in order to improve the process. This helps the project team to work more effective on the problem and saves time due to not dealing with the symptoms.

Cause	1. Why?	2. Why?	3. Why?	4. Why	5. Why?
Cause 1. The job description of each department is not specified clearly in project managing operations.	There is no one in charge, that has knowledge about Project Management.	The firm does not give weight to projects.	The main revenue comes from standart parts produced for a specific customer.		
Cause2. The way of handling projects is not clarified.	There is not a proper Project Management System in the Firm.	The firm does not have a project management culture.	The firm works according to Purchase Orders and produces standart parts and does not have experience of handling projects.	The main customer is an aviation firm and all system is build upon their demands.	The main reason to enter this sector was that specific customer.
Cause 3. The order of operations are not set clearly.	Projects are not planned properly before orders are given to the suppliers.	There are no project engineers adequate to perform the planning.	The projects are entered to the firm by the Business Development Department.	There is not a Project Management Office that is in full charge of projects.	
Cause 6. Data relevant to the project is not given properly to the Engineering Department.	The information transmission is not made by a project professional.	The firm has only one and he is been used in Production Planning Department.	The firm does not have the capability to assign the right person to the right job.	Evaluation of the white-collars can not be made properly.	There is not a good evaluation system for staff qualification.

*Figure 12: 5-Why Method [44]*

### 3.4.3.11 Fishbone Diagram

The fishbone diagram is a way to organize the possible causes behind a given problem. This diagram is also known as cause-and-effect diagram. The usage of this diagram is very simple. The team members gather together and draw a schema looking like a fishbone (Figure 13). Firstly, the problem statement is placed at the head of the fish. Afterwards, the causes are grouped before filling the skeleton of the fishbone. These groups are written at the end of each bone of the fish. Every member tells their opinion about what the causes effecting the process are, and these causes are written down under the corresponding groups defined at the beginning. This helps the team to clearly visualize the problem and the causes. Below these steps are given in a simple order;

- a. State the problem
- b. Document Possible Causes
- c. Complete the Diagram

After completing the fishbone diagram, the project team starts to collect data using a check sheet. Using a pareto chart, the causes that have the most significant effect on the problem are defined. As you can see, various tools are combined to resolve the problem. It is the team's choice which tools to use according to ease and efficiency of use.

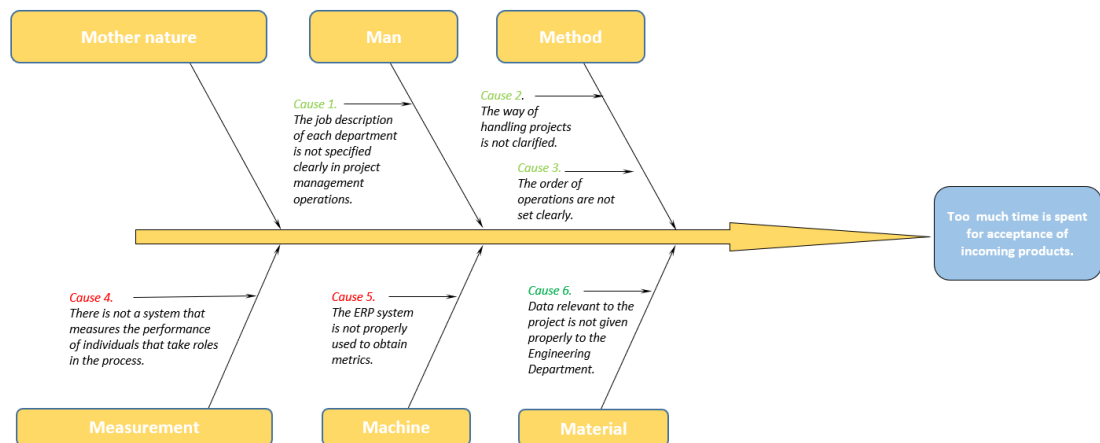

**Figure 13: Fishbone Diagram [44]**

### 3.4.3.12 Control Plan

Control plans are documents which contain product or process characteristics that must be monitored or controlled during a manufacturing process or operation, including measurement methods to be used and necessary reaction plans in case of detecting defects. Control plans can be in different formats due to the organization's needs, but most commonly used is excel format. In order to prepare an effective control plan, the information below must be written down into it;

- a. Clear Product Specifications
- b. Process Failure Modes and Effects Analysis (PFMEA)
- c. Effective Measurement Methods and Reaction Plans
- d. Internal Audit

Control plans can be used in every step, across a process's life time, therefore it is a good way of detecting defects in early stages of a process. Also, it gives the ability to collect more reliable data of which part of the processes produces more defects.

### 3.4.3.13 Statistical Process Control (SPC)

Statistical Process Control is made by using control charts. There are a few charts mostly used in this method. The main aim of this method is to detect special-cause variation early to prevent more defective parts being produced and providing a better understanding of the process in order to reduce unwanted variation. These charts are used according to different situations. These situations can be divided into two; SPC for Variable Data and SPC for Attribute Data.

#### 1. SPC for Variable Data;

The variable data is measured and plotted on a continuous scale. The most common variable data control charts are as follows;

**a. X-Bar and R Chart:** This is the most commonly used variable-data control chart and is used mainly for subgroup sample sizes consisting of 2 to 9 samples. The most common sample size is 5. Two charts make up the X-Bar and R chart: one plots the subgroup average and the other plots the subgroup range. Both charts have upper and lower control limits to detect out-of-control conditions.

**b. Individuals and Moving Range:** This chart is used when a single part is measured at each inspection time.

**c. Average and Standard Deviation Chart:** This chart is used for very high subgroup sizes more than 9. These charts are also known as “X-Bar and S Chart” again one plotting the subgroup average and other plotting the subgroup range.

**d. Median and Range Chart:** These charts are rarely used because of the subgroup sample size range must be between 3 and 5. These charts are an alternative to X-Bar and R charts when the sample average cannot be easily calculated.

## 2. SPC for Attribute Data;

Attribute control charts can whether expand to include defect counts and percent defective or they can focus only on one feature at a time like variable control charts. The four most common attribute control charts are;

- a. Fraction Defective (p Chart):** This chart tracks the percentage of nonconforming units in a large sample size. The subgroup sizes are greater than 50. These charts can also work with variable subgroup sizes.
- b. Number Defective (np Chart):** These charts monitor the total defective unit quantity when a constant subgroup size is used. The subgroup size is typically 50 or more.
- c. Number of Defects (c Chart):** A c chart monitors total defects and is useful when multiple potential defects exist for each part.
- d. Defects per Units (u Chart):** u charts also monitor total defects as it is in c charts; the only difference is that they focus on average defects per unit.

According to the sample subgroup sizes and the ranges of them, selecting the suitable control chart is providing working with data sets easier. The main aim of all these charts are detecting defects and deficiencies among samples.

### 3.5. Operational Benefits of Six-sigma

“There are several operational benefits of using six-sigma. First, the organization systems get more driven, significant cost savings can be made, waste reduction can be achieved, inventory needs can be decreased, number of rework and defects can be reduced and most important one of course, customer satisfaction can be increased” [16].

### 3.5.1. Making the Organization Systems more Driven

“Six-Sigma efficiency is impossible to achieve if the mode of production used by the organization is craft production. To be efficient enough to run processes that have less than 3.4 defects per million, organizations need to be systems dependent. Thus, Six-sigma mind set helps transform a people driven organization into a process driven one” [16].

### 3.5.2. Reduction of Personnel Time and Required Skill

“Six-sigma results in massive cost savings to the organization involved. These cost savings are highlighted by the fact that after a Six-sigma project any organization has considerably less requirement for labor hours. Also, the requirement of skilled laborer’s is also reduced. Hence, both these factors combined have an effect of drastically reducing the labor bill of the organization” [16].

### 3.5.3. Reduction of Wastage

“Six-sigma projects realize a large amount of their financial value from their ability to eliminate or at least reduce wastage. Since the process is critically analyzed for costs and corresponding value addition, measures are taken to eliminate wastage to a large extent” [16].

### 3.5.4. Reduction of Inventory Needs

“An ancillary benefit of Six-sigma projects is that it creates a system which is much more efficient than the earlier one. Hence the organization can implement systems like Just in Time Inventory practices and cut still more costs “[16].

### 3.5.5. Reduction of Reworks and Defects

“Organizations are plagued with defective processes which result in the manufacturing of defective products” [16]. Six-sigma implementations often pay off in the long-run, reaching almost zero defects.

### 3.5.6. Increasing Customer Satisfaction

“Customers do not like unreliable products or organizations. This can be verified by the fact that many companies that have implemented Six-sigma have not only found their costs reduced but their market share increased considerably. Hence, Six-sigma is also capable of positively impacting the marketing of the firm” [16]. Customer satisfaction is essential as much as profitability especially for long term benefits.

### 3.6. Roles and Responsibilities in a Six-sigma Project

There are several roles in a six-sigma project for the people in an organization (Table 3). According to their positions and tasks to perform, six different roles are defined such as; [11]:

1. Deployment Leader (DL): are business leaders who establish objectives and measures.
2. Champion (CH): are managers who are also sponsors who are responsible for ensuring process improvements.
3. Master Black Belt (MBB): are responsible for the improvement of BB's and the other. Their goal is to construct a six-sigma culture in the organization.
4. Black Belt (BB): Are experienced in six-sigma and can decide on a project, make a project, and lead project teams.
5. Green Belt (GB): Are part-time project leaders and can work as subject matter experts in projects.
6. Yellow Belt (YB): can participate in project teams and have basic knowledge of six-sigma tools and procedures.

*Table 3: Some example of functional roles vs. six-sigma roles [11]*

<b>Functional Role in Organization</b>	<b>Six-sigma Role in a Six-sigma Project</b>
Managing Director	Deployment Leader
General Manager	Champion
Head – Quality	Master Black Belt
Manager – Quality	Black Belt
Team Leader – Operations	Green Belt
Associates - Operations	Yellow Belt

## CHAPTER 4

### LEAN SIX-SIGMA APPROACH

#### 4.1. What is Lean Six-sigma?

Lean Six-sigma can be defined as a combination of Six-sigma Methodology and Lean Manufacturing. For decades, these two approaches were used in production to improve some parameters like customer satisfaction, profitability, waste reduction, lowering cost, decreasing defect rate etc. These approaches have similarities and differences. Six-sigma focuses on decreasing DPMO and increasing the sigma level in terms of quality. Although six-sigma brings a high standard in quality, there is another important factor to increase customer satisfaction that has been never considered before and even neglected was due date. The idea of using six-sigma to reduce total cycle time and considering due date as an important factor for customer satisfaction was proposed by Jack Welch. The main idea was that to use tools of both approaches and building up a new blended approach whose base was the DMAIC method. In the figure below, you can see the difference between lean and six-sigma point-of-view, and lean six-sigma [40].

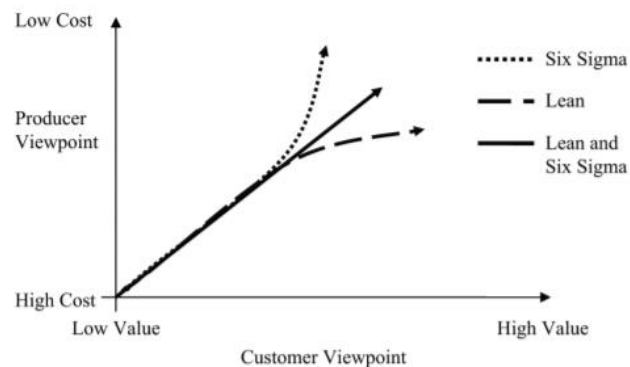

Figure 14: Viewpoint differences between Lean & Six-sigma [40]

## 4.2. Five Essentials of Lean Six-sigma

In lean six-sigma, five essentials must be considered as laws to acquire a strong lean six-sigma discipline and to be successful in implementing and managing lean six-sigma which are; customer quality needs, flexibility, focus, velocity and complexity & cost.

### 4.2.1 Customer Quality Needs

The customer needs are the highest priority for companies. In order to fulfill these needs, quality improvement must be made. The growth of companies depends on customer satisfaction.

### 4.2.2 Flexibility

In the last half century, the market needs change very fast. Therefore, shop floors must be flexible and easily adaptable to instant order changes or incoming new orders. Reacting fast gives a huge advantage to companies in the competitive market.

### 4.2.3 Focus (Pareto Rule)

As it is mentioned before in the definition in pareto principle, 20% of the activities in a process cause 80% of the problems and delay. So, focusing on the right processes to improve is very important to resolve problems fast, and obtain a greater impact on quality improvements.

#### 4.2.4 Velocity

In order to speed up any process in production, the amount of work-in-progress (WIP) must be held as low as possible. As it is known in Little's Law; The speed of any process is inversely related to the amount of WIP parts.

#### 4.2.5 Complexity and Cost

“The complexity of the service or product offering generally adds more costs and WIP than either poor quality (low Sigma) or slow speed (un-Lean) process problems. So one of your early improvement targets may well be reducing the numbers or varieties of products and services your work group is involved in” [46].

## **CHAPTER 5**

### **APPLICATION OF LEAN SIX-SIGMA**

Due to high degree of confidentiality, the name of the company which is working in aviation and defense industry will be mentioned as XYZ. Also, some information related to parts produced such as names, will not be shared. The important specifications data used in the project will not be changed, in order to reflect actual results obtained in this project.

#### **5.1 COMPANY PROFILE**

XYZ company working in aviation and defense industry, is specialized in sheet metal, and is producing detailed parts for both internal defense industry firms and global aviation firms. The firm is actively working on more than 10 different programs, containing more than 50 different projects, resulting with a production rate of approximately 50.000 to 60.000 parts per month.

As the aviation and defense industries require very tight specifications, the production is more sophisticated than in other sheet metal productions. There are many qualification and certification procedures through the way to become a supplier for such tier one firms.

XYZ Aviation & Defense was founded in 2013 as the latest member of its company group. The group has four companies other than XYZ which are in automotive industry for more than 30 years. The know-how claimed in automotive, has given the strength to make investment on the fifth company in this sector.

Approximately 120 people ( 90 blue and 30 white collars) work for XYZ, in 20 different workstations and 7 different departments. The annual growth rate of the

company is about %17. This study is focused on one of the workstations called the press brake workstation, where two press brakes are used.

## 5.2. DEFINITION OF THE LEAN SIX-SIGMA PROJECT

The main motivation behind the project at the press brake station was related on the will to increase efficiency. The press brakes were working two shifts per day, with no delayed parts at all. But some of the parts with bend sides, were bended at the hydroform press, which is a much more sophisticated and costly press. The main aim was to increase efficiency and production rate at the press brakes to obtain better utilization of the machine resources. There were two important advantages; one was to produce more parts at the press brake, so the variable cost per part would be decreased according to the production rate, and secondly decreasing the workload on the hydroform press, which would give the opportunity to produce more parts which can only be produced at that press. As you can guess, the parts produced at the hydroform press are more difficult to bend according to their geometry, and mostly bigger in size. Increasing excess capacity in the hydroform press would have a great positive impact on the firm's monthly revenue.

Besides the monetary advantage, the increase in quality was another fact that was considered. Before the bending operation starts for each batch of a specific part, the press brakes are calibrated and some unused metal parts with same thickness are bended before starting the actual order. This is made to check the results of that bending operation, and to be sure that the machines' bending settings are prepared correctly. It is in fact the definition of setup time for press brakes, which had to be reduced as much as possible in this study, to increase the quality and production rate together.

Clearly, the aim in this study was to use lean six-sigma methodology on a specific workstation and make improvements, but while deciding on the workstation, our focus was to improve another workstation indirectly. It was mentioned before that in the lean six-sigma methodology; the improvements that cost less in manners of time and money and have a bigger impact, must be applied first to obtain significant results in a shorter term. Under these circumstances, improving the press brake as the focus of this study,

would improve also the hydroform press workstation, resulting with two workstation improvements by doing one project.

### 5.3. STEPS FOLLOWED IN THE PROJECT

The project is made by following up the steps of DMAIC methodology. As it is mentioned in the previous sections, DMAIC is the most common methodology consists of five main steps; define, measure, analyze, improve and control. In this section, all these five steps will be followed one by one and explained in detail for this project.

#### 5.3.1. Define Phase

At the beginning of define phase, a project charter is constructed. This charter holds information such as;

- a. Project title
- b. Process definition
- c. Problem statement
- d. Project scope
- e. Project leader
- f. Project sponsor
- g. Project members
- h. Project objectives (objective & current state data)

The constructed charter for the project can be seen in table 4 below (appendix 1);

Table 4: Project Charter [45]

<b>Project charter</b>	
<b>Project title</b>	<i>Reduce setup time in Press Brake Workstation</i>
<b>Process</b>	<i>Forming operations of sheet metals in the Press Brake, Daily process, 6 people involved.</i>
<b>Problem statement</b>	<i>Too much time is spent for setup operations in the Press Brake Workstation.</i>
<b>Project scope</b>	<i>Reduce total setup time in Press Brake Workstation</i>
<b>Project leader</b>	<i>Burak Alper</i>
<b>Project sponsor</b>	<i>Ali P.</i>
<b>Team members</b>	<i>Emre Ö., Halil D., Selami K.</i>
<b>Project objectives</b>	
<b>Objective</b>	<b>Current state data</b>
<i>Reduce time spent on setup operations in Press Brake.</i>	<i>200 min+ setup (average) per shift on Press Brake</i>

Secondly, the SIPOC diagram is prepared to define the suppliers, inputs and their requirements, process, outputs and their requirements, and lastly the customers for the project. The SIPOC diagram can be seen below in figure 15 (appendix 2).

Suppliers	Inputs	Req.	Process	Outputs	Req.	Customers
Manufacturing Department	Exchange Die	Performing setup operations via changing dies.		Total parts processed daily.	Daily control of processed parts in Press Brake	QualityControl Department
Planning Department	Press Brake Production Plan	Defining the lot and operation date of each part.		Total time spent for setup operations daily.	Daily control and acceptance of semi-product	Manufacturing Department
Warehouse	Transportation of Die	Transportation of die to the Press Brake Workstation				

Figure 15:SIPOC Diagram [45]

Thirdly, a process map which shows the process flow has been constructed. All operations related to the focused process are defined in this map (Figure 16) which can be found in a larger scale in appendix 3.

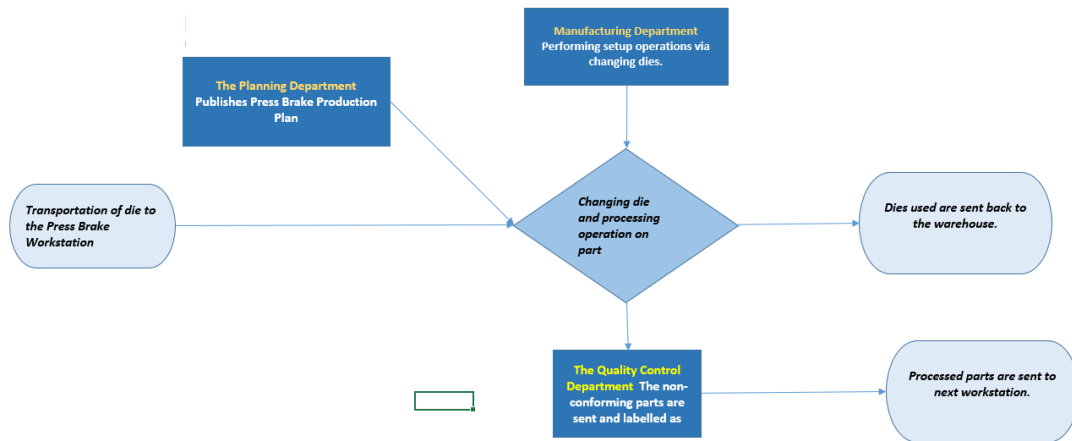

*Figure 16: Process Map [45]*

Afterwards, the stakeholders of the project are defined. This is crucial to identify the impacts of the stakeholders on the project success, their attitudes on the project and actions to be taken (Table 5). The stakeholder table can be found in wide scale in appendix 4.

*Table 5: Stakeholders of the Project [45]*

Stakeholder name and function	Impact on the project success	Attitude to the project	Action to be taken
	Low   Medium   High	Negative   Neutral   Positive	Keep informed   Involve actively   Monitor
██████████ (Press Operator)	High	Positive	Involve Actively
██████████ (Press Operator)	High	Neutral	Involve Actively
██████████ (Manufacturing Engineer)	Low	Neutral	Keep Informed
██████████ (Planning Engineer)	High	Positive	Involve Actively
██████████ (Warehouseman)	High	Negative	Keep Informed
██████████ (Quality Controller)	High	Neutral	Keep Informed

Finally, the last step in the define phase; data collection plan is prepared in order to complete the define phase (Table 6) which can be found in appendix 5.

*Table 6: Data Collection Plan [45]*

Measure in SIPOC	Metric	Measure Definition	When?	Who will measure the data?
<i>P= Time spent in exchange operation per lot.</i>	<i>Mins. spent per setup operation</i>	<i>Average time spent in exchange of dies in Press Brake Workstation.</i>	<i>January 2017 - December 2018</i>	<i>Emre Öztürk - Burak Alper</i>

### 5.3.2. Measure Phase

In this section, some measurements of the current system were made. This step is important for the project because at the control phase, the same measurements will be made and a comparison between the initial and final measurements will be taken into consideration to find out the project success. The results for the initial measurements are as follows;

- 1) 200 mins setup (average) per shift on Press Brake
- 2) Availability Ratio: %59.89 per shift (average/shift)
- 3) Machine Setup Performance: %53.23 per shift (average/month)
- 4) %59.85 Overall Equipment Effectiveness (average of year 2017)
- 5) Average run time per shift (maximum 520 min): 363.2
- 6) Average tool change duration: 7.2 min
- 7) 239622 parts processed in 2017 (for a 12-month period)

After the improvements are made, same measurements have been made and compared to these data to find the project success.

### 5.3.3. Analyze Phase

The first part of the analyze phase is the fishbone diagram. The causes were defined using a fishbone diagram (Figure 17) which can be found in appendix 6.

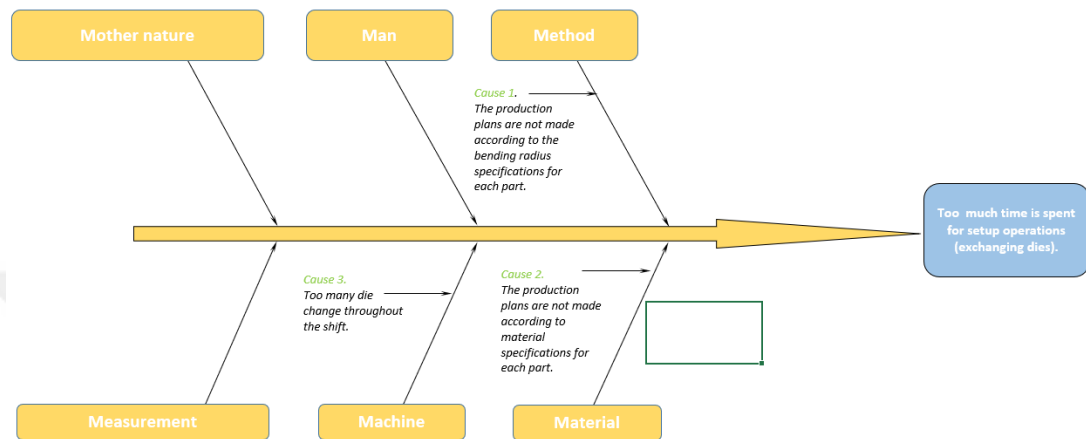

Figure 17: Fishbone Diagram of the Project [45]

Secondly, 5 Why method is applied to find the root causes. Note that the initial causes used in this method was obtained from the fishbone diagram. The 5 Why method (Figure 18) can be found in appendix 7.

Cause	1. Why?	2. Why?	3. Why?	4. Why	5. Why?
Cause 1. The production plans are not made according to the bending radius specifications for each part.	The bending radiuses are not given by the Engineering Department	The planning department should have warned them but they didn't.	There was not an engineer fully eligible of planning operations.		
Cause 2. The production plans are not made according to material specifications for each part.	The bending radiuses are not given by the Engineering Department	The planning department should have warned them but they didn't.	There was not an engineer fully eligible of planning operations.		
Cause 3. Too many die change throughout the shift.	Parts come with a mixed order with different bending radiuses.	The bending radiuses are not given by the Engineering Department	No one was aware of an enormous impact on the setup time.	There were no improvement engineers in the firm.	

Figure 18: 5 Why method used in the Project [45]

### 5.3.4. Improve Phase

In this phase two tools were used. These were the implementation difficulty matrix and the implementation plan respectively. The implementation difficulty matrix shows information about the difficulty of implementation versus impact on the project. Using this matrix, the decision of the starting improvement was made. Here the aim is to make the improvement which has the most impact on the project but also is easier to implement compared to other improvements (Figure 19). The matrix can also be found in appendix 8.

**IMPACT DIFFICULTY MATRIX**

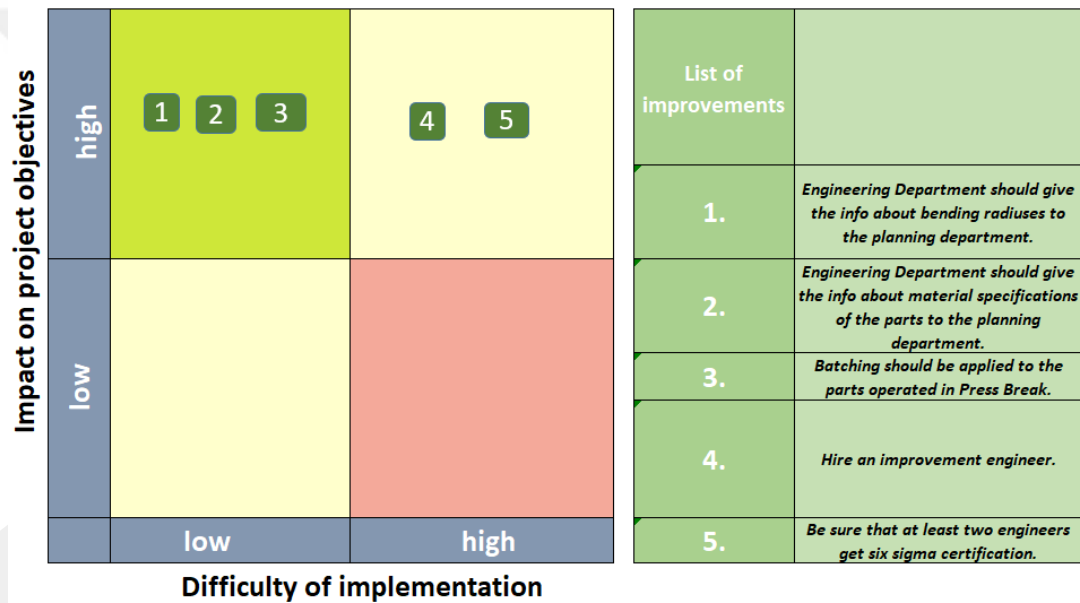

*Figure 19: Implementation Difficulty Matrix [45]*

After constructing the implementation difficulty matrix, decisions on the improvements were made. These decisions were used to construct an implementation plan (Table 7). The implementation plan can be found in appendix 9.

Table 7: Implementation Plan [45]

1. Actions				
Improvement	Impact on objective	Start & finish date	Owner	Status
The bending radiuses of each part is given to the planning department	The planning department considers the bending radiuses and groups the parts according to that information.	Start: 1 January 2018 End: 31 December 2018	Burak ALPER	Done
The material specification of each part is given to the planning department	The planning department considers the material specifications and groups the parts according to that information.	Start: 1 January 2018 End: 31 December 2018	Burak ALPER	Done
2. Trainings				
Training objectives	Participants	Place	Start & finish date	Status
New system implementation	██████████ (Warehouseman) ██████████ (Operator) ██████████ (Operator)	Meeting Room	25 December 2017 (2 hours training)	Done
3. Communication				
Audience	Key Message	Sender	Start & finish date	Status
4. Standard Operating Procedure				
Procedure name and version	Owner	Action	Start & finish date	Status
Grouping the part according to their bending radius and material specs. And put the production into a row according to that information.	Burak ALPER	New Published	28 December 2017	Done

After all the parts with bending operations are separated into batches according to their material types and bending radiuses, the daily workload was given in order to produce parts in same batches to reduce setup times. The parts with same bending radius but different materials cannot be batched, because of the difference of spring back ratio of materials. The part batches can be seen in appendices 10 & 11.

The main idea behind batching was to reduce total setup time in the press brake by decreasing the number of die changes throughout the shift. When we batched the parts according to their bending radiuses and materials, meaning that they have the same spring back ratio, gave us the opportunity to use the same die for all the parts in that batch (figure 20). A picture of the press brake can be seen in appendix 12 to better understand the components of the press brake, and where the dies we mentioned are used.

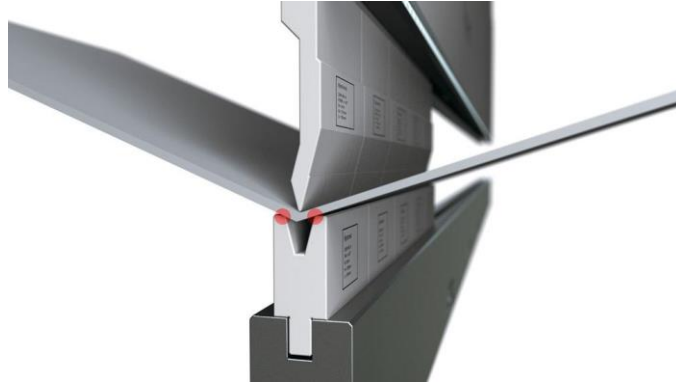

*Figure 20: Press brake die & Bending Operation [51]*

### 5.3.5. Control Phase

In the control phase, the same measurements made in the measure phase were repeated, and the results below were obtained;

- 1) 82 min setup (average) per shift on Press Brake
- 2) Availability Ratio: %74.84 per shift (avg.)
- 3) Machine Setup Performance: %76.8 per shift (avg.)
- 4) %71.82 OEE (avg. of March to November 2018)
- 5) Average run time per shift (maximum 520 min): 411.5
- 6) Average tool change duration: 6.0 min
- 7) 240180 parts processed in 2018 (except December)

In the last chapter, the results found in the control phase were compared to the ones obtained in measure phase.

The measurements made in the measurement phase are repeated at the control phase, and obtained data were used to compare the overall production rate, OEE, efficiency per shift, average tool change duration, etc. The results show that the project is quite successful by giving the opportunity to produce approximately 33% more parts with bending operations. This study has taken one month to be fully implemented and data collection and observations to measure the success of the project took 9 months. The

data was compared to last year's results. All data has been calculated based on monthly averages. The monthly averages, comparisons and the improvement ratios can be seen in table 9 below.

*Table 8 : Comparison of measurements [45]*

	Start Data December 2017	Final Data September 2018	Improvement Ratio Percentage
Total average setup time (mins) per shift on Press Brake	200.4	82.2	59.0%
Average Availability Ratio per shift	59.9%	75.0%	12.5%
Average Machine Setup Performance per shift (	53.2	76.8	14.4%
Average Overall Equipment Effectiveness (monthly average)	59.9	71.8	12.3%
Average run time per shift (mins)	363.2	411.5	13.3%
Average tool change duration (mins)	7.2	6.0	16.7%
Average number of parts processed per month (pieces/month)	19968.5	26686.6	33.6%

## **CHAPTER 6**

### **CONCLUSION**

The defense and aviation company, which is the subject of this study, has decided to make an improvement in press brake workstation and hydroform press. Lean Six Sigma method was decided to be used in this project. First, a lean six-sigma approach was constructed, and the steps were followed. Several tools were used to complete every step of the project. Along these steps, the causes, the root causes, possible alternatives that can be used were determined. A selection among them was made and as a result, using a batching system was decided on, where the parts that have bending operations were assigned to batches according to their bending radiuses and material types. After this step, the production was made according to this batching system and several key performance indicators like; the production rates, OEE, and other data such as overall daily setup time were carefully monitored for nine months. The improvement resulted with an 33.6% increase in average monthly production. This study as a solid example how beneficiary a lean six-sigma method can be, if it is followed and managed in a right manner. Further studies can be focused on the hydroform press, in which a 3-dimension calculation should be made, and an algorithm should be defined in order to decide on batches to be produced together and increase production rate.

To the best of our knowledge, there is no lean six-sigma application used in production in defense and aviation industry. The closest study is proposed by Al Muhareb et. al (2014) which is focused on improving service quality in aviation industry [53]. We hope our study will be useful in production related lean six-sigma applications, especially in defense and aviation industry.

## REFERENCES

- [1] Thang, L., Goh, T.-N., Lam, S. and Zhang, C. (2007), "Fortification of Six-sigma: expanding the DMAIC toolset", *Quality and Reliability Engineering International*, Vol. 23 No. 1, pp. 3-18
- [2] Kwak, Y.H.; Anbari, F.T. (2004)," Benefits, Obstacles and Future of Six-sigma Approach", *Technovation*, 26, 708-715.
- [3] Chowdhury, S. (2001) "The power of Six-sigma: An inspiring tale of how Six-sigma is transforming the way we work", *Financial Times\Prentice-Hall*, London.
- [4] Antony, J., Banuelas, R. (2002) "Key ingredients for the effective implementation of six-sigma program", *Measuring Business Excellence* 6 (4), 20-27
- [5] Pande, P.S.; Neuman, R. P.; Cavanagh, R.R. (2000)" The Six-sigma Way: How GE, Motorola and other top companies are honing their performance", McGraw Hill, New York.
- [6] McClusky, R., (2000) "The rise, fall and revival of six-sigma", *Measuring Business Excellence* 4 (2), 6-17
- [7] Markarian, J. (2004) "Six-sigma: quality processing through statistical analysis ", Reinforced Plastics.
- [8] Abdelhamid, T.S. (2003)" Six-sigma in Lean Construction Systems: Opportunities and Challenges", *Proceedings of 11th Annual Conference on Lean Construction*.

- [9] Laureani, A., Antony, J., (2016) "Leadership-a critical success factor for the effective implementation of Lean Six-sigma", *Total Quality Management and Business Excellence*.
- [10] Akgün, O., (2010) "Six-sigma and Statistical Applications in Automotive Sector" *Thesis in Engineering Management*, Marmara University, İstanbul.
- [11] Six-sigma Revealed, study book ([www.sixsigma-institute.org](http://www.sixsigma-institute.org))
- [12] Kwak, Y.H.; Anbari, F.T.: "Success Factors in Managing Six-sigma Projects", *Project Management Institute Research Conference*, London (2004).
- [13] Taylor, J.R.; "An Introduction to Error Analysis: The Study of Uncertainties in Physical Measurements." 128-129 ISBN 093570275X (1999)
- [14] De Mast, Jeroen, and Joran Lokkerbol. "An analysis of the Six-sigma DMAIC method from the perspective of problem solving." *International Journal of Production Economics* 139.2 (2012): 604-614.
- [15] Keller, Paul Andrew. "Six-sigma deployment: A guide for implementing six-sigma in your organization." QA Pub., LLC, 2001.
- [16] Access: 25 May 2019, Six-sigma article ([www.managementstudyguide.com](http://www.managementstudyguide.com))
- [17] Sokovic, Mirko, Dusko Pavletic, and K. Kern Pipan. "Quality improvement methodologies—PDCA cycle, RADAR matrix, DMAIC and DFSS." *Journal of achievements in materials and manufacturing engineering* 43.1 (2010): 476-483.
- [18] Selvi, K., and Rana Majumdar. "Six-sigma-overview of DMAIC and DMADV." *International Journal of Innovative Science and Modern Engineering* 2.5 (2014): 16-19
- [19] De Koning, Henk, and Jeroen De Mast. "A rational reconstruction of Six-Sigma's breakthrough cookbook." *International Journal of Quality & Reliability Management* 23.7 (2006): 766-787.

- [20] Access: 5 June 2019, <https://goleansixsigma.com/dmaic-five-basic-phases-of-lean-six-sigma>
- [21] critical to quality (CTQ). BusinessDictionary.com. Web Finance, Inc. July 14, 2019<<http://www.businessdictionary.com/definition/critical-to-quality-CTQ.html>>
- [22] Project Management Institute “*A Guide to the Project Management Body of Knowledge – PMBOK Guide 6<sup>th</sup> Ed.*” ANSI/PMI 99-001-2017 (2017): 317-318.
- [23] Holweg, Matthias. "The genealogy of lean production." *Journal of operations management* 25.2 (2007): 420-437.
- [24] Cusumano, Michael A. "The Japanese automobile industry: Technology and management at Nissan and Toyota." (*Harvard East Asian Monographs, No. 122*) Harvard University Press, Boston. (1985): 2181-2181.
- [25] Fujimoto, T., “The Evolution of a Manufacturing System at Toyota”. *Oxford University Press, Oxford.* (1999).
- [26] Ohno, Taiichi. “Toyota production system: beyond large-scale production”. *crc Press*, (1988) 75-79.
- [27] Shingo, Shigeo. *A revolution in manufacturing: the SMED system*. Routledge, 2019.
- [28] Womack, James P., and Daniel T. Jones. "Lean thinking—banish waste and create wealth in your corporation." *Journal of the Operational Research Society* 48.11 (1997): 1148.
- [29] Access: June 19, 2019, <http://www.lean-manufacturing-junction.com/lean-manufacturing-principles>

- [30] Chen, Lixia, and Bo Meng. "The application of value stream mapping based lean production system." *International journal of business and management* 5.6 (2010): 203.
- [31] S. Shingo, "A revolution in manufacturing, the SMED system", Productivity Press, 1985.
- [32] Ulutaş, Berna. "An application of SMED Methodology." *World academy of science, engineering and technology* 79 (2011): 101.
- [33] Costa, Eric Simão Macieira da, et al. "An industrial application of the SMED methodology and other Lean production tools." *4th International Conference on Integrity, Reliability and Failure* Paper Ref: 3927 (2013): 1-8.
- [34] Rewers, Paulina, et al. "Tools and methods of Lean Manufacturing-a literature review." *Technological forum Department of Manufacturing Technology, Czech Technical University in Prague* (2016).
- [35] Antosz, K., et al. "Lean Manufacturing." *Doskonalenie produkcji. Rzeszów: Oficyna Wydawnicza Politechniki Rzeszowskiej* (2015).
- [36] Womack, J.P., Jones, D.T. and Roos, D., *The Machine that Changed the World: The Triumph of Lean Production*, New York, Rawson Macmillan (1990).
- [37] Hüttmeir A., Treville S., Ackere A., Monnier L., Prenninger J., Trading off between heijunka and just-in-sequence, *Int. Journal Production Economics*, Vol. 118, (2009) 501-507
- [38] Durlik I., *Inżynieria zarządzania. Strategia i projektowanie systemów produkcyjnych*, cz. 1 i 2, Agencja Wydawnicza Placet, Warszawa (1996).
- [39] Hamrol A., *Strategie i praktyki sprawnego działania. Lean, Six-sigma i inne*. Wydawnictwo PWN, Warszawa (2015).
- [40] Arnheiter, E.D. and Maleyeff, J., "The integration of lean management and six-sigma", *The TQM Magazine*, Vol. 17 No. 1, (2005): 5-18.

- [41] Access: 14 June 2019 <https://circuitglobe.com/accuracy-and-precision.html>
- [42] Access: 16 June 2019 <https://www.mindtools.com/pages/article/ctq-trees.htm>
- [43] Access: 16 June 2019 <https://www.unlimitedpriorities.com/2006/04/the-kano-model/>
- [44] Alper, Burak, “*Reduce time in the acceptance of outsourced semi-products*”, Lean Six-sigma Green Belt Project, (2018)
- [45] Alper, Burak, “*SMED Application in Press Brake Station*”, Lean Six-sigma Black Belt Project, (2018).
- [46] George M.; Rowlands D. and Kastle B.: “*What is Lean Six-sigma?*”, McGraw Hill, USA (2004) 2-94
- [47] Tennant, Geoff (2001). *SIX-SIGMA: SPC and TQM in Manufacturing and Services*. Gower Publishing, Ltd. p. 25. ISBN 0-566-08374-4.
- [48] Access: 29 August 2019 <https://www.wikizero.org/index.php?q=aHR0cHM6Ly9lbi53aWtpcGVkaWEub3JnL3dpa2kvTWVhbl9zaGlmdA%3D> "ISO 13053:2011". ISO.
- [49] Gygi, Craig; DeCarlo, Neil; Williams, Bruce (2005). *Six-sigma for Dummies*. Hoboken, NJ: Wiley Publishing, Inc. , 23. ISBN 0-7645-6798-5.
- [50] El-Haik, Basem; Suh, Nam P. (2005-04-15). *Axiomatic Quality*. John Wiley and Sons. p. 10. ISBN 978-0-471-68273-8.
- [51] Access: 09 September 2019 <https://www.thefabricator.com/article/bending/the-rules-of-press-brake-tool-selection>
- [52] Access: 09 September 2019 <https://www.harsle.com/PRESS-BRAKE-MACHINE-FORMING-id6915616.html>

[53] Al Muhareb, T. M., & Graham-Jones, J. (2014). Using lean six-sigma in the improvement of service quality at aviation industry: Case study at the departure area in KKIA. *International Journal of Social, Management, Economics and Business Engineering*, 8(1), 150-156.



## APPENDIX 1

<b>Project charter</b>	
<b>Project title</b>	<i>Reduce setup time in Press Brake Workstation (TC-106)</i>
<b>Process</b>	<i>Forming operations of sheet metals in the Press Brake, Daily process, 6 people involved.</i>
<b>Problem statement</b>	<i>Too much time is spent for setup operations in the Press Brake Workstation.</i>
<b>Project scope</b>	<i>Reduce total setup time in Press Brake Workstation</i>
<b>Project leader</b>	<i>Burak Alper</i>
<b>Project sponsor</b>	<i>Ali P.</i>
<b>Team members</b>	<i>Emre Ö., Halil D., Selami K.</i>
<b>Project objectives</b>	
<b>Objective</b>	<b>Current state data</b>
<i>Reduce time spent on setup operations in Press Brake.</i>	<i>200 min+ setup (average) per shift on Press Brake</i>

## APPENDIX 2

### SIPOC

Suppliers	Inputs	Req.	Process	Outputs	Req.	Customers
Manufacturing Department	Exchange Die	Performing setup operations via changing dies.	<pre> graph LR     A([Transportation of die to the Press Brake Workstation]) --&gt; B[Changing die and performing the press operation]     B --&gt; C([Sending die back to the warehouse])             </pre>	Total parts processed daily.	Daily control of processed parts in Press Brake	Quality Control Department
Planning Department	Press Brake Production Plan	Defining the lot and operation date of each part.		Total time spent for setup operations daily.	Daily control and acceptance of semi-product	Manufacturing Department
Warehouse	Transportation of Die	Transportation of die to the Press Brake Workstation				

# APPENDIX 3

## PROCESS MAP

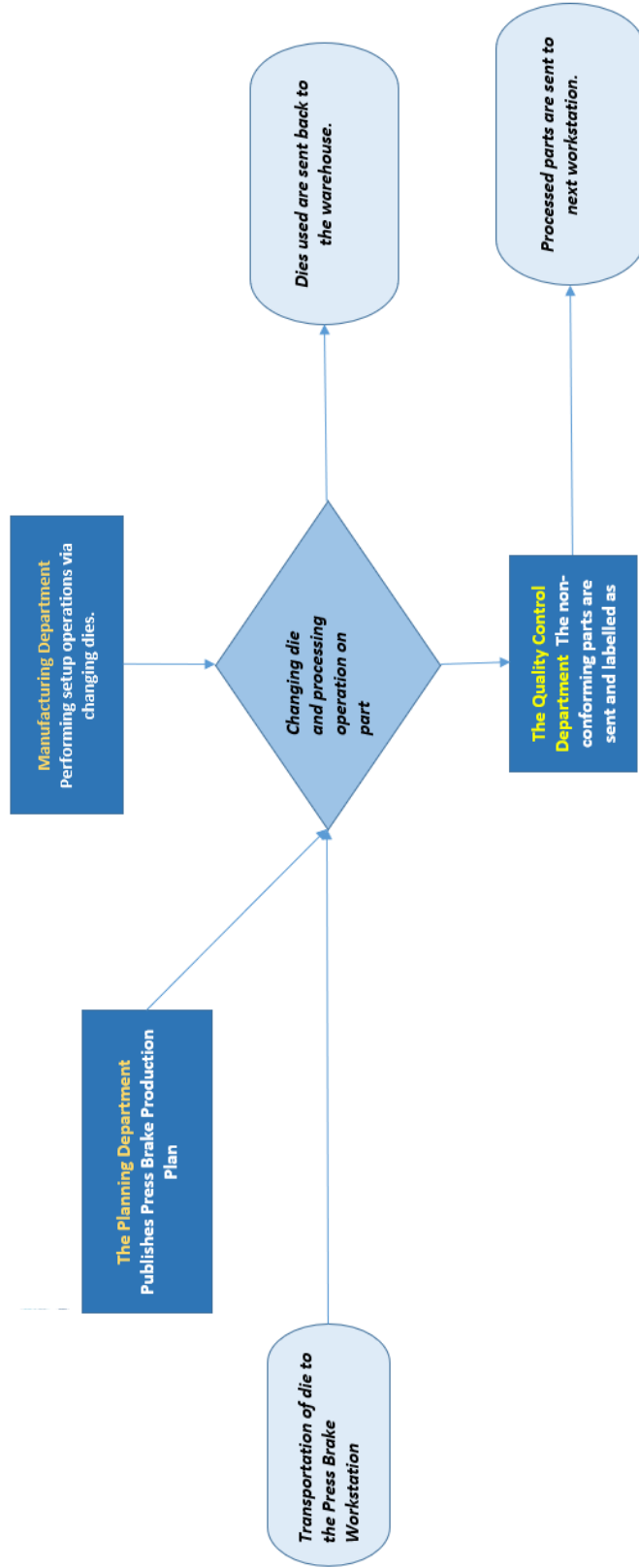

## APPENDIX 4

### STAKEHOLDERS

Stakeholder name and function	Impact on the project success	Attitude to the project	Action to be taken
██████████ (Press Operator)	Low   Medium   High	Negative   Neutral   Positive	Keep informed   Involve actively   Monitor
██████████ (Press Operator)	High	Positive	Involve Actively
██████████ (Press Operator)	High	Neutral	Involve Actively
██████████ (Manufacturing Engineer)	Low	Neutral	Keep Informed
Burak Alper (Planning Engineer)	High	Positive	Involve Actively
██████████ (Warehouseman)	High	Negative	Keep Informed
██████████ (Quality Controller)	High	Neutral	Keep Informed

## APPENDIX 5

### DATA COLLECTION PLAN

Measure in SIPOC	Metric	Measure Definition	When?	Who will measure the data?
P= Time spent in exchange operation per lot.	Mins. spent per setup operation	Average time spent in exchange of dies in Press Brake Workstation.	January 2017 - December 2018	Emre Öztürk - Burak Alper

# APPENDIX 6

**ICHIKAWA DIAGRAM**

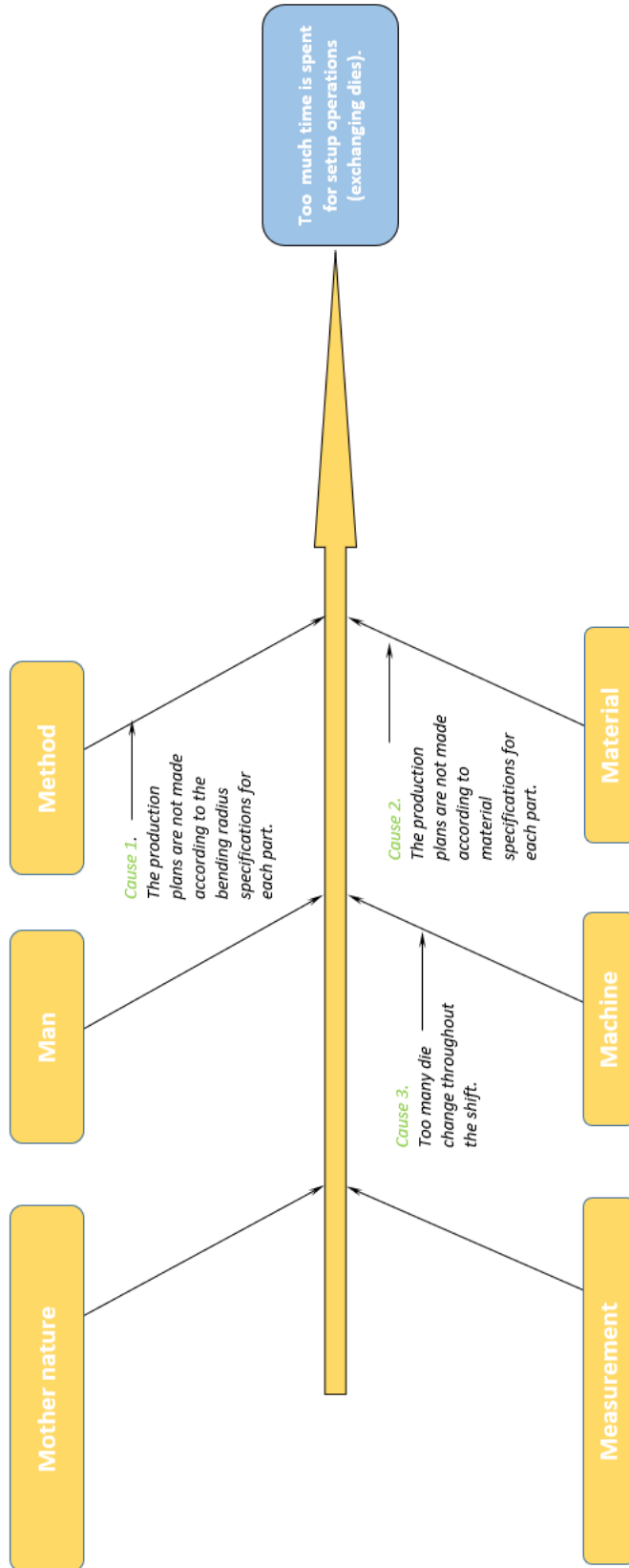

## APPENDIX 7

### 5 WHY?

Cause	1. Why?	2. Why?	3. Why?	4. Why	5. Why?
Cause 1. The production plans are not made according to the bending radius specifications for each part.	The bending radiuses are not given by the Engineering Department	The planning department should have warned them but they didn't.	There was not an engineer fully eligible of planning operations.		
Cause 2. The production plans are not made according to material specifications for each part.	The bending radiuses are not given by the Engineering Department	The planning department should have warned them but they didn't.	There was not an engineer fully eligible of planning operations.		
Cause 3. Too many die change throughout the shift.	Parts come with a mixed order with different bending radiuses.	The bending radiuses are not given by the Engineering Department	No one was aware of an enormous impact on the setup time.	There were no improvement engineers in the firm.	

## APPENDIX 8

### IMPACT DIFFICULTY MATRIX

Impact on project objectives	Difficulty of implementation				
	1	2	3	4	5
high					
low					
	low				high
List of improvements					
1.					Engineering Department should give the info about bending radiuses to the planning department.
2.					Engineering Department should give the info about material specifications of the parts to the planning department.
3.					Batching should be applied to the parts operated in Press Break.
4.					Hire an improvement engineer.
5.					Be sure that at least two engineers get six sigma certification.

## APPENDIX 9

### IMPLEMENTATION PLAN

<b>1. Actions</b>					
Improvement	Impact on objective	Start & finish date	Owner	Status	
The bending radiuses of each part is given to the planning department	The planning department considers the bending radiuses and groups the parts according to that information.	Start: 1 January 2018 End: 31 December 2018	Burak ALPER	Done	
The material specification of each part is given to the planning department	The planning department considers the material specifications and groups the parts according to that information.	Start: 1 January 2018 End: 31 December 2018	Burak ALPER	Done	
<b>2. Trainings</b>					
Training objectives	Participants	Place	Start & finish date	Status	
New system implementation	(Warehouseman) Selami Kara (Operator) [REDACTED] (Operator)	Meeting Room	25 December 2017 (2 hours training)	Done	
<b>3. Standard Operating Procedure</b>					
Procedure name and version	Owner	Action	Start & finish date	Status	
Grouping the part according to their bending radius and material specs. And put the production into a row according to that information.	Burak ALPER	New Published	28 December 2017	Done	

# APPENDIX 10

Sample of Classifications of parts according to specifications.

A	B	C	D	E	F	G	H	I	J	K	L	M	N	O	P	Q	R	S	T	U	V	W	X		
1	Stok Kodu	Parça No	Bileşen	Bileşen Açıklaması	Proje	SCON	Gage	Length	Width	FCOM	Mal. Spec	Alasım	10	20	30	40	50	60	70	80	90	100	110	120	
2	4000000000	89Z28101-1	1010000120	AMS 4027 6061 T6 1.6	BWC	1.6	310	310	16	AMS 4027	6061	TC260	TC239	TC133	TC215	TC109	TC420	TC660	TC864	DHO	OSI	TC022			
3	4000000001	141W0558-31	1010000029	AMS 4048 7075 CLAD TO 1.6	BWC	1.6	76.2	76.2	162	QQ-A-250/13	7075	TC260	TC339	TC133	TC109	TC420	TC551	TC106	TC533	TC420	TC402	TC864	DHO		
4	4000000003	253V0114-4ATA	1010000114	QQ-A-250/4 2024 BARE TO 1.6	BWC	1.6	81	127	142	QQ-A-250/4	2024	TC260	TC339	TC133	TC109	TC420	TC551	TC106	TC533	TC420	TC551	TC410	TC220	TC103	
5	4000000004	141W0558-47	1010000029	AMS 4048 7075 CLAD TO 1.6	BWC	1.6	86.58	65.5	162	QQ-A-250/13	7075	TC260	TC339	TC133	TC109	TC420	TC551	TC106	TC533	TC420	TC402	TC864	DHO		
6	4000000005	232W1801-214ATA	1010000109	QQ-A-250/4 2024 BARE T3 1.6	BWC	1.6	177.8	114.3	T3	QQ-A-250/4	2024	TC260	TC339	TC133	TC109	TC420	TC661	TC106	TC420	TC864	DHO	OSI	TC022		
7	4000000007	284W1811-19	1010000109	QQ-A-250/4 2024 BARE T3 1.6	BWC	1.6	67.31	88.9	T3	QQ-A-250/4	2024	TC260	TC339	TC133	TC109	TC420	TC661	TC106	TC420	TC864	DHO	OSI	TC022		
8	4000000008	284W1811-31	1010000098	QQ-A-250/5 2024 CLAD T3 1.6	BWC	1.6	61.6	76.74	T3	QQ-A-250/5	2024	TC260	TC339	TC133	TC109	TC420	TC661	TC106	TC420	TC864	DHO	OSI	TC022		
9	4000000009	141W3862-7	1010000098	QQ-A-250/5 2024 CLAD T3 1.6	BWC	1.6	525.78	160.02	T3	QQ-A-250/5	2024	TC260	TC339	TC133	TC109	TC420	TC661	TC106	TC420	TC864	DHO	OSI	TC022		
10	4000000010	284W1870-46	1010000114	QQ-A-250/4 2024 BARE TO 1.6	BWC	1.6	213.36	71.12	142	QQ-A-250/4	2024	TC260	TC339	TC133	TC109	TC420	TC551	TC106	TC420	TC551	TC410	TC420	TC194	TC420	
11	4000000012	181A8035-25	1010000099	QQ-A-250/5 2024 CLAD TO 1.6	BWC	1.6	83.98	152.4	142	QQ-A-250/5	2024	TC260	TC339	TC133	TC109	TC420	TC551	TC106	TC420	TC551	TC122	TC108	TC103	H02	
12	4000000013	146A9705-21	1010000099	QQ-A-250/5 2024 CLAD TO 1.6	BWC	1.6	304.8	101.6	142	QQ-A-250/5	2024	TC260	TC339	TC133	TC109	TC420	TC551	TC106	TC420	TC551	TC108	TC103	TC103	TC660	
13	4000000014	141A8130-21	1010000098	QQ-A-250/5 2024 CLAD T3 1.6	BWC	1.6	457.2	55.88	T3	QQ-A-250/5	2024	TC260	TC339	TC133	TC109	TC420	TC660	TC664	TC664	DHO	OSI	TC022	F5003		
14	4000000015	232W1801-134ATA	1010000109	QQ-A-250/4 2024 BARE T3 1.6	BWC	1.6	215.9	101.6	T3	QQ-A-250/4	2024	TC260	TC339	TC133	TC109	TC420	TC661	TC106	TC420	TC964	DHO	OSI	TC022		
15	4000000016	147A8125-74	1010000098	QQ-A-250/5 2024 CLAD T3 1.6	BWC	1.6	360.68	157.48	142	QQ-A-250/5	2024	TC260	TC339	TC133	TC109	TC420	TC551	TC114	TC533	TC122	H02	TC410	TC215		
16	4000000017	149A8109-55	1010000062	QQ-A-250/12 7075 BARE TO 1.6	BWC	1.6	152.4	127	162	QQ-A-250/12	7075	TC260	TC339	TC133	TC109	TC420	TC551	TC103	TC420	TC660	TC864	DHO	OSI	TC022	
17	4000000018	141A4841-160	1010000098	QQ-A-250/5 2024 CLAD T3 1.6	BWC	1.6	223.52	45.72	T3	QQ-A-250/5	2024	TC260	TC339	TC133	TC109	TC420	TC551	TC103	TC420	TC660	TC864	DHO	OSI	TC022	
18	4000000019	232W1801-92	1010000109	QQ-A-250/4 2024 BARE T3 1.6	BWC	1.6	86.9	65.5	T3	QQ-A-250/4	2024	TC260	TC339	TC133	TC109	TC420	TC551	TC106	TC420	TC864	DHO	OSI	TC022		
19	4000000020	232W1801-9187	1010000109	QQ-A-250/4 2024 BARE T3 1.6	BWC	1.6	76.2	63.5	T3	QQ-A-250/4	2024	TC260	TC339	TC133	TC109	TC420	TC551	TC106	TC420	TC864	DHO	OSI	TC022		
20	4000000021	232W1801-9127	1010000109	QQ-A-250/4 2024 BARE T3 1.6	BWC	1.6	88.9	63.5	T3	QQ-A-250/4	2024	TC260	TC339	TC133	TC109	TC420	TC551	TC106	TC420	TC864	DHO	OSI	TC022		
21	4000000022	232W1801-197	1010000109	QQ-A-250/4 2024 BARE T3 1.6	BWC	1.6	76.2	63.5	T3	QQ-A-250/4	2024	TC260	TC339	TC133	TC109	TC420	TC551	TC106	TC420	TC864	DHO	OSI	TC022		
22	4000000023	141A1310-15	1010000029	AMS 4048 7075 CLAD TO 1.6	BWC	1.6	457.2	152.4	162	QQ-A-250/13	7075	TC260	TC339	TC133	TC109	TC420	TC551	TC114	TC122	TC420	TC402	TC533	TC103		
23	4000000024	141A8185-14	1010000029	AMS 4048 7075 CLAD TO 1.6	BWC	1.6	177.8	101.6	162	AMS 4048	7075	TC260	TC339	TC133	TC109	TC420	TC551	TC114	H02	TC420	TC402	TC220	TC103		
24	4000000025	141A8322-15	1010000011	QQ-A-250/13 7075 CLAD TO 1.27	BWC	1.27	101.6	88.9	162	QQ-A-250/13	7075	TC260	TC339	TC133	TC109	TC420	TC551	TC106	TC533	TC420	TC402	TC103	TC660		
25	4000000026	141W2642-14	1010000011	QQ-A-250/13 7075 CLAD TO 1.27	BWC	1.27	152.4	76.2	162	QQ-A-250/13	7075	TC260	TC339	TC133	TC109	TC420	TC551	TC106	TC533	TC420	TC402	TC864	DHO		
26	4000000027	143A9438-8	1010000011	QQ-A-250/13 7075 CLAD TO 1.27	BWC	1.27	128.54	121.92	162	QQ-A-250/13	7075	TC260	TC339	TC133	TC109	TC420	TC551	TC106	TC533	TC420	TC402	TC864	DHO		
27	4000000028	143A9473-2	1010000011	QQ-A-250/13 7075 CLAD TO 1.27	BWC	1.27	528.32	34.62	162	QQ-A-250/13	7075	TC260	TC339	TC133	TC109	TC420	TC551	TC106	TC122	TC533	TC420	TC402	TC103		
	result	Data	2024	2219	6013	6061	7075	7475	Complete	Sayfa1	Double R	16 R	8,7 R	9,1 R	10 R	11 R	12 R	12 R	12 R	12 R	12 R	12 R	12 R	12 R	12 R
												8 R	7,1 R	6,4 R	6 R	5,6 R	5,33 R	5 R	...						

# APPENDIX 11

Sample of Classifications of parts according to specifications.

A	B	C	D	E	F	G	H	I	J	K	L	M	N	O	P
1. Büküm T	2. Büküm T	1. Açı	1. Radius	2. Açı	2. Radius	3. Açı	3. Radius	4. Açı	4. Radius	5. Açı	5. Radius	6. Açı	6. Radius	Stok Kodu	Parça No
2 T3	x	x	x											4000001484	111A1502-11
3 T3	x	x												4000000392	111A1502-12
4 T3	76	0.19	76	0.19	76	0.19	76	0.19	90	1.11	90	0.89		4000001265	111A1502-15
5 T3	76	0.19	76	0.19	76	0.19	76	0.19	90	1.11	90	0.89		4000000705	111A1502-16
6 T3	90	0.25	90	0.25										4000002069	111A1512-21
7 T3	90	0.25	90	0.25										4000000978	111A1512-22
8 T3	3.6	0.25												4000001489	141A1310-11
9 T3	3.6	0.25												4000001410	141A1310-12
10 T3	3.6	0.25												4000002373	141A1310-12F
11 O	90	0.16	90	0.16	90	0.16	90	0.16	90	0.16				4000002079	141A4833-10
12 O	90	0.16	90	0.16	90	0.16	90	0.16	90	0.16				4000000176	141A4833-9
13 T3	90	0.16												4000000888	141A5137-11
14 T3	90	0.16												4000000938	141A5137-12
15 T3	90	0.16												4000000109	141A5137-37
16 T3	90	0.16												4000000110	141A5137-38
17 T3	86.5	0.16												4000000544	141A5137-73
18 T3	86.5	0.16												4000001091	141A5137-74
19 T3	61.39	0.19												4000002043	141A8223-2
20 T3	65.24	0.19												4000001046	141A8223-3
21 T3	65.24	0.19												4000002386	141A8223-3F
22 W	78	0.19												4000001099	141A9192-3
23 W	69	0.19												4000001394	141A9192-4
24 O	90	0.12												4000001124	141A9402-6
25 O	65	0.12												4000002225	141A9501-909
26 O	65	0.12												4000002225	141A9501-909
27 T3	90	0.12	90	0.12	90	0.12	90	0.12	90	0.12				4000000183	141T5824-129
28 T3	90	0.12	90	0.12	90	0.12	90	0.12	90	0.12				4000000457	141T5824-130

## APPENDIX 12

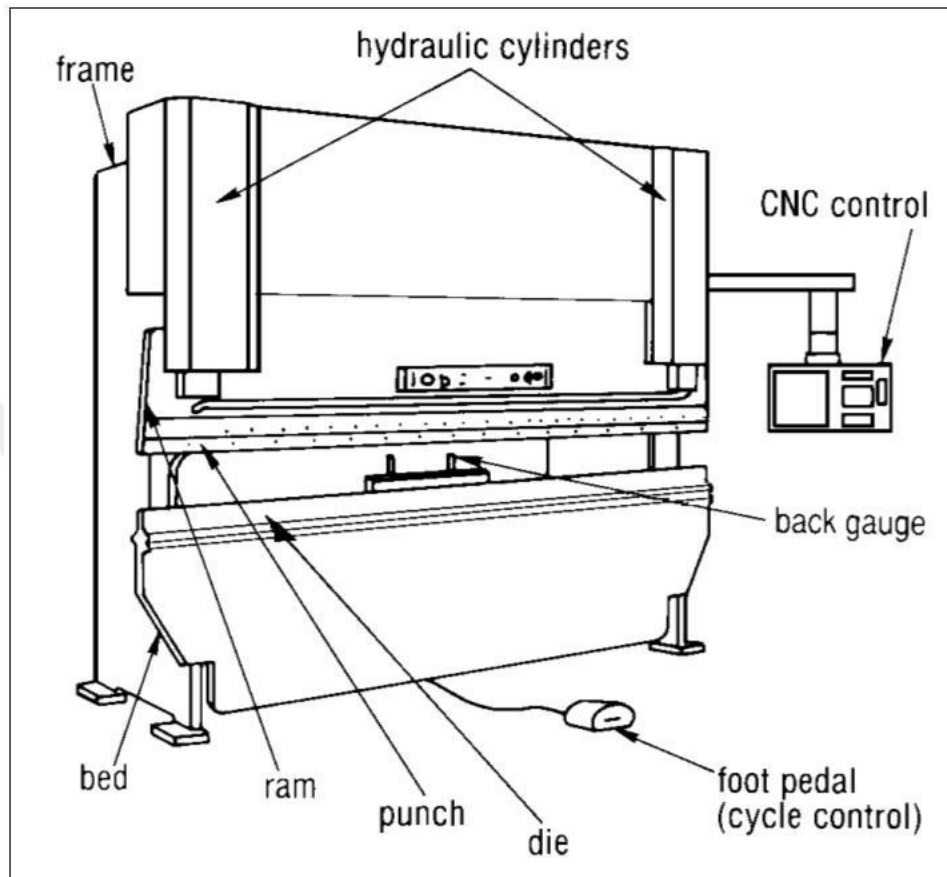

Components of a Press Brake [52]

## CURRICULUM VITAE

### PERSONAL INFORMATION

Surname, Name: ALPER, Burak

Nationality: .....

Date and Place of Birth: .....

Marital Status: .....

Phone: +90 .....

Email: .....

### EDUCATION

Degree	Institution	Year of Graduation

### WORK EXPERIENCE

Year	Place	Enrollment

### FOREIGN LANGUAGES

### HOBBIES