

ÇANKAYA UNIVERSITY

GRADUATE SCHOOL OF NATURAL AND APPLIED SCIENCES

ELECTRONIC AND COMMUNICATION ENGINEERING

MASTER THESIS

**APPLICATION AND DEVELOPMENT OF CONTROL CENTER AND
FREELOG TRACKING FOR 24/7 LOGISTICS MANAGEMENT MODEL**

REŞAT ŞEKER

MARCH , 2014

Title of the Thesis :APPLICATION AND DEVELOPMENT OF CONTROL CENTER AND FREELOG TRACKING FOR 24S4 LOGISTICS MANAGEMENT MODEL

Submitted by : Reşat ŞEKER

Approval of the Graduate School of Natural and Applied Sciences, Çankaya University

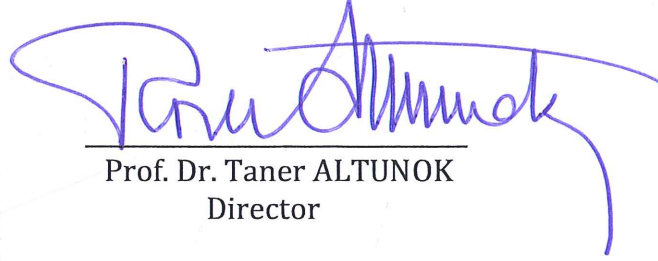

Prof. Dr. Taner ALTUNOK
Director

I certify that this thesis satisfies all the requirements as a thesis for the degree of Master of Science.

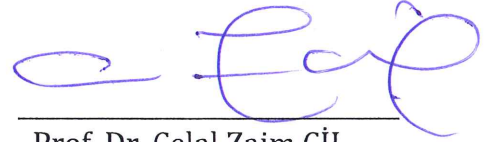

Prof. Dr. Celal Zaim ÇİL
Head of Department

This is to certify that we have read this thesis and that in our opinion it is fully adequate, in scope and quality, as a thesis for the degree of Master of Science.

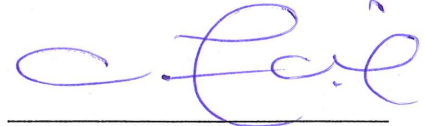

Prof. Dr. Celal Zaim ÇİL
Supervisor

Examination Date: 21 March 2014

Examining Committee Members:

Prof. Dr. Celal Zaim ÇİL

(Çankaya Univ.)



Prof. Dr. Taner ALTUNOK

(Çankaya Univ.)

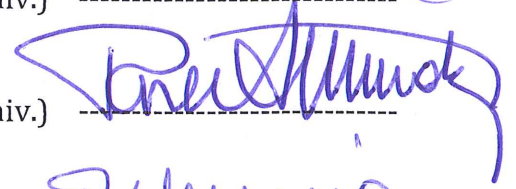

Assist. Prof. Dr. Hüseyin Emir ŞİMŞEK (Ankara Univ.)

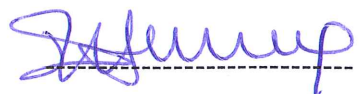

STATEMENT OF NON-PLAGIARISM

I hereby declare that all information in this document has been obtained and presented in accordance with academic rules and ethical conduct. I also declare that, as required by these rules and conduct, I have fully cited and referenced all material and results that are not original to this work.

Name, Last Name: Reşat ŞEKER

Signature: 

Date: 21 MARCH 2014

ABSTRACT

APPLICATION AND DEVELOPMENT OF CONTROL CENTER AND FREELOG TRACKING FOR 24S4 LOGISTICS MANAGEMENT MODEL

ŞEKER, Reşat

M.Sc., Department of Electronics and Communication Engineering

Supervisor: Prof. Dr. Celal Zaim ÇİL

MARCH 2014, 58 Pages

In this thesis, Freelog Logistic, Freelog Tracking and Control Center Development and Application one of the subsystems of San-tez project has been run on the vehicle tracking system.

In this context, data types that global positioning system provides has been examined and then studies on tracking and navigation components, performance test of the system and evaluation of the test results have been carried out, test procedures have been conducted in the test conditions similar to real conditions by using hardware used in the system, data have been collected with developed software, also the accuracy of the test procedure has been confirmed with the obtained results by examining the factors that affect the performance of the system.

Key words: GPS, Navigation Test, Freelog, NMEA

ÖZ

24S4 LOJİSTİK YÖNETİM MODELİ İÇİN FREELOG TAKİP VE KONTROL MERKEZİ GELİŞTİRİLMESİ VE UYGULAMASI

ŞEKER, Reşat

Yüksek Lisans, Elektronik ve Haberleşme Mühendisliği Anabilim Dalı

Tez Yöneticisi: Prof. Dr. Celal Zaim ÇİL

MART 2014, 58 Sayfa

Bu tez çalışmasında, Freelog Lojistik Freelog Takip ve Kontrol Merkezi Geliştirilmesi ve Uygulaması San-tez projesinin alt sistemlerinden biri araç takip sistemi üzerinde çalışılmıştır.

Bu çerçevede; küresel konum belirleme sisteminin (GPS) sunduğu veri tipleri incelenmiş ardından takip ve navigasyon bileşenleri, sistemin performans testi ve test sonuçlarının değerlendirilmesi üzerine çalışılmıştır, gerçek duruma benzer test şartlarında ve sistemde kullanılan donanımlar kullanılarak test işlemleri gerçekleştirilmiş, geliştirilen yazılımla veriler toplanmış, ayrıca sistemin performansını etkileyen faktörler incelenerek oluşturulan test prosedürünün doğruluğu alınan sonuçlarla teyit edilmiştir.

Anahtar Kelimeler: GPS, Navigasyon Testi, Freelog, NMEA

Dedicated to my Parents...

GCCRIIS

ACKNOWLEDGEMENTS

I would like to thank my supervisor, Prof. Dr. Celal Zaim ÇİL who has been extremely helpful during the preparation of the thesis.

I would also like to acknowledge Prof. Dr. Taner ALTUNOK for his kind help and suggestions during the preparation of the thesis.

I would also like to thank Assist. Prof. Dr. H. Hakan MARAŞ for providing me the test data and his valuable discussions and comments.

Finally, I also would like to thank to all my friends, especially to Mustafa GÜNEY and Ümit Çağlayan ARSLAN, for their encouragement throughout this work.

TABLE OF CONTENTS

STATEMENT OF NON-PLAGIARISM	iii
ABSTRACT	iv
ÖZ	v
ACKNOWLEDGEMENTS	vii
TABLE OF CONTENTS	viii
LIST OF TABLES	x
LIST OF FIGURES	xi
LIST OF ACRONYMS	xiii
INTRODUCTION	1
CHAPTER 1	5
1.1 Literature Survey and the Development of the Concept.....	5
1.2 Determination of Software Modules Throughout the Necessities	5
1.3 Determination and Assurance of the Server System Hardware	8
1.4 Definition and Assurance of the Call Center Hardware.....	13
CHAPTER 2	14
2.1 The Necessary Web System Needed for the Applicant Transporter Firms Administration to the System.....	14
2.2 Development of the Software of the Mobile Tablet Used for Consideration of the Open Auctions on the System (Android Based) for the Transporter Vehicle Owners	16
2.3 Providing of Necessary Hardware for Data Transmission to Transporter Vehicle	19
CHAPTER 3	21
CHAPTER 4	24
4.1 National Marine Electronics Association (NMEA) Protocols	24
4.1.1 NMEA 2.0 Sentences	25
4.1.2 GPRMC Sentence properties	26
4.1.3 GPGGA Sentence properties.....	27
4.2 Selective Availability (SA)	27
4.3 Standart Positioning Service (SPS).....	28
4.4 Dilution of Precision “DOP”	28

4.5 Performing the Tests	29
4.5.1 Test software	30
4.5.2 Test software code.....	31
4.5.3 Test hardware	35
4.5.4 Comparing GPS Modules	37
4.6 Test Process.....	38
4.7 Format Conversion.....	39
4.8 Landmark Measurement and Point Distribution	40
4.9 Test Route Data.....	43
4.10 Test Route Examination.....	45
5. CONCLUSION AND FUTURE WORK.....	49
6. REFERENCES.....	52
7. APPENDIX.....	54
7.1.DAM1575A4 GPS Active Antenna	54
7.2 Landmark Test Parameters.....	55
7.3.Test Route GPS Data List	56
7.4 Stationary Point Landmark Measurement Raw Data List	56
7.5 Autocad Drawing File.....	57
CURRICULUM VITAE.....	58

LIST OF TABLES

Table 1.	Project Staff.....	3
Table 2.	Software Requirement Analysis.....	6
Table 3.	GPRMC Data Parts.....	26
Table 4.	GPRMC Data Structure.....	26
Table 5.	GPGGA Data Parts.....	27
Table 6.	GPGGA Data Structure.....	27
Table 7.	GPS Module Comparision.....	38
Table 8.	Landmark Measurement Test Results.....	42
Table 9.	A Subset of the Test Route Data List (Converted).....	44
Table 10.	The Test Route Parameters.....	47
Table 11.	Comparision of Parameters Between the Static and Dynamic Tests	48

LIST OF FIGURES

Figure 1.	24S4 Logistical Administration Model.....	2
Figure 2.	Vehicle Tracking System.....	3
Figure 3.	Freelog Bidding Process Data Flow.....	7
Figure 4.	Infrastructure of Freelog Data Communication.....	9
Figure 5.	Freelog Web Site Screen.....	9
Figure 6.	Freelog Cargo Definition Screen Details.....	10
Figure 7.	Freelog Data Flow.....	12
Figure 8.	Freelog Call Center Personnel Hardware.....	13
Figure 9.	Freelog Vehicle Tracking Screen.....	16
Figure 10.	Freelog SQL Server Database Current Account Screen.....	18
Figure 11.	Freelog Mobile Computer	19
Figure 12.	Freelog GPS Vehicle Tracking Module Top Side.....	20
Figure 13.	Freelog GPS Vehicle Tracking Module Bottom Side.....	20
Figure 14.	General Communication Structure.....	20
Figure 15.	Vehicle Computer Unit Login Screen.....	21
Figure 16.	Freelog Vehicle Computer Bidding Detail Information Screen.....	22
Figure 17.	Vehicle Computer Bidding Examination Screen.....	22
Figure 18.	Good and Poor DOP States.....	29
Figure 19.	Test Software Interface.....	30
Figure 20.	Test Software Flow Chart.....	31
Figure 21.	GPS Hardware Top View.....	35
Figure 22.	GPS Hardware Rear Side Ublox NEO-6M GPS Receiver Module and U-Blox Leon G100 Module.....	35
Figure 23.	U-Blox NEO-6M Block Diagram.....	36
Figure 24.	DAM 1575A4 Type Antenna.....	36
Figure 25.	Test Setup.....	37
Figure 26.	Test Route	39

Figure 27.	Data Conversion Sample.....	40
Figure 28.	Landmark and Maximum Error Point.....	41
Figure 29.	Sample Landmark.....	41
Figure 30.	Landmark Point Distribution(Time).....	42
Figure 31.	Landmark Point Distribution(Circular).....	43
Figure 32.	GPS Test Route Results.....	45
Figure 33.	Sample Perpendicular Measurement.....	46
Figure 34.	GPS Measurements Points on Digital Map (Autocad).....	46

GCCRS

LIST OF ACRONYMS

3G	: 3. Generation
APN	: Access Point Name
ASCII	: American Standart Code for Information Interchange
CRM	: Customer Relationship Management
DOP	: Dilution of Precision
DGPS	: Differential Global Positioning System
EDGE	: Enhanced Data Rates for GSM Evolution
GDOP	: Geometric Dilution of Precision
GNSS	: Global Navigation Satellite System
GPRS	: General Packet Radio Service
GPS	: Global Positioning System
GSM	: Global System for Mobile
HDOP	: Horizontal Dilution of Precision
IGS	: International GNSS Service
LNA	: Low Noise Amplifier
M2M	: Machine to Machine
MDB	: Microsoft Access Database
NMEA	: National Marine Electronics Association
PCB	: Printed Circuit Board
PPS	: Precise Positioning Service
PVT	: Position, Velocity, Time
RTK	: Real Time Kinematic
SA	: Selective Availability
SQL	: Structured Query Language
SMS	: Short Message Service
SPS	: Standard Positioning Service
USB	: Universal Serial Bus

USNO : United States Naval Observatory
UTC : Universal Time Coordinated
TCP : Transmission Control Protocol
VSWR : Voltage Standing Wave Ratio

GCPRIS

INTRODUCTION

In the field of logistics, the delivery of the right material, in the right time and to the right location appear to be the essential element. In the history, transportation, as the content of all the logistics activities of carrying trade, has developed rapidly and reached to a wide spot in which it is possible to execute the work order to delivery, the stocking, processing and inflowing of resources and furthermore preparing the papers for trans pass and customhouse.

Aside from the augmentation of competition and the changing tendencies of business, the fast development in the information sector has caused changes in the understanding of the logistics and several successful developments achieved in the sector. Acceleration, getting easier and the reliability in the information sharing brought about variety of progresses such as timing, providence in the costs and efficient administration figures.

The aim of this Project is to evaluate the inert capacity in Turkey's logistic system, efficient use of resources and improving a successful logistic system. Three main elements take place in the axis of this project. These are the customer, the transporter and the FREELOG center. FREELOG center carries an eligibility of a control center in which automation is fully performed and connection between the customer and the transporter is built. This center is supported with software and up-to-date technological accoutrements. This technology includes the information technology based (Software Accoutrement) Research-Development and innovation. Figure 1 shown project components and between relationship.



Figure 1. 24S4 Logistical Administration Model

With the efficient use of system, prescience claims a 50% advantage in economical field, environment factors and in several other fields. In the structure of this FREELOG tracking and Controlling center Project, there are main operation center, call center and main computer, Global System for Mobile/ Global Positioning System/General Packet Radio Service “GSM/GPS/GPRS” systems, inner system and mobile device systems, interface software and all other auxiliary devices supporting those systems. Figure 2 shown’s project communication components between relationships.

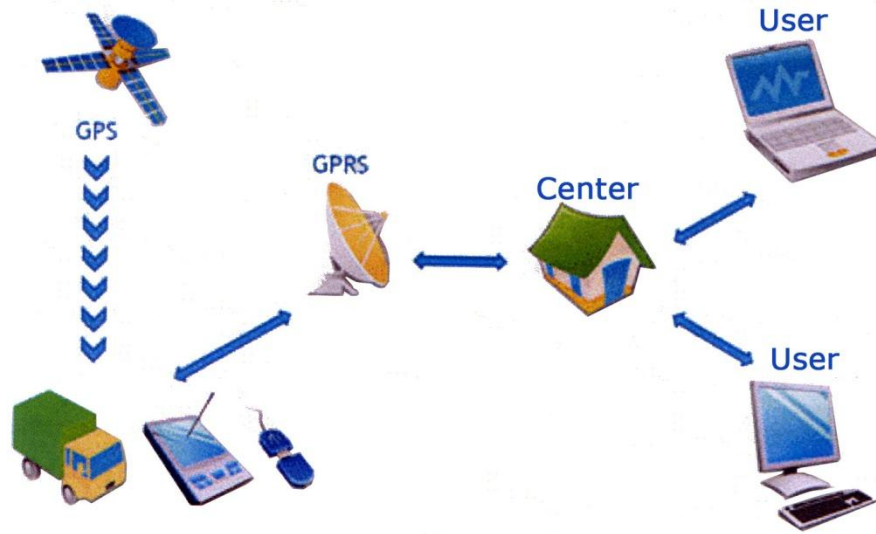

Figure 2. Vehicle Tracking System

This project has been accepted and realized in Çankaya University together with Kobi Logistics CO. as ‘Santez’ project #00992.STZ.2011-2

The Project was realized by the following staff.

Table 1. Project Staff

STAFF	CORPORATION	POSITION
Prof. Dr. Taner ALTUNOK	ÇANKAYA ÜNİVERSİTESİ	PROJECT EXECUTER
Reşat ŞEKER		THESIS STUDENT
Sevgi CANPOLAT		THESIS STUDENT
Prof. Dr. Mehmet Reşit TOLUN	TED ÜNİVERSİTESİ	ASSISTANT RESEARCHER
Assistant Professor Nilay ALÜFTEKİN	YILDIRIM BEYAZIT ÜNİVERSİTESİ	ASSISTANT RESEARCHER
Assistant Professor Recai KUŞ	SELÇUK ÜNİVERSİTESİ	ASSISTANT RESEARCHER
Mehmet Akif KAYMAZ	KOBİ LOJİSTİK A.Ş.	ASSISTANT STAFF
Hilal EKİN	KOBİ LOJİSTİK A.Ş.	ASSISTANT STAFF
Pınar SOPACI	KOBİ LOJİSTİK A.Ş.	ASSISTANT STAFF
Murat ÇEVİK	KOBİ LOJİSTİK A.Ş.	ASSISTANT STAFF

As the Project staff and thesis student, aside from attending and contributing to all project work packages, following important subjects have been accomplished by myself:

- Studying the GPS formats,
- Choosing the proper format,
- Developing the test software,
- Developing the test procedures, and
- Implementing the test procedures and evaluation of the results.

All these work are given in Chapter 4.

Although mainly performed under the responsibilities of the staff listed in Table 1, the work packages are defined in the other chapters in the thesis to define the FREELOG System as a whole.

GCPRIS

CHAPTER 1

In this chapter observed methods within the project, supply of infrastructure of the software which will build the system and by figuring out the necessities of software for building up of the software approaches have been discussed.

1.1 Literature Survey and the Development of the Concept

The needs of the customer about the transportation techniques and mobile devices have been studied within the Project. The needs have been determined and to meet those needs a market research has taken place to develop the system. The decision of which of the system needs are going to be obtained from the firm and the university and which ones are going to be obtained from the exterior sources has been made. Researches for the needed materials, examination of the used Technologies and resource planning have been done.

The data necessities for the upcoming device have been investigated. By specifically examining the existing systems, functional necessities have been determined. Before passing to the development stage, feasibility study for the analyses of costs and profits have taken place. Meeting with the producers of Vehicle Tracking Device and Programs have been done. Similarities of features and functions of the used tracking systems have been interrogated.

For GSM infrastructure Machine to Machine, General Packet Radio Service, 3. Generation, Enhanced Data rates for GSM Evolution, Access Point Name “M2M, GPRS, 3G, EDGE, APN etc.”, types of subscription, data traffic, costs and their revenues have been discussed with the GSM operators.

1.2 Determination of Software Modules Throughout the Necessities

Communications with firms for the Electronic Signature have taken place, executive applications and platforms have been examined. Furthermore, interviews with GSM

operators about Mobile Signature have taken place. Following results have been achieved, as listed in Table 2:

Table 2. Software Requirement Analysis

	Name of the Service	Session-1	Session-2	Session-3
1	FREELOG Tracking and control center software service support cost	<ul style="list-style-type: none"> - Definition of products - Firm information recognition module - Transporter information recognition module - Vehicle information recognition module - Driver information recognition module 	<ul style="list-style-type: none"> - Insurance information recognition module - Transaction of firm-producer current accounts - Transaction of transporter current account 	
2	FREELOG Interactive web registration and control softwares development cost	<ul style="list-style-type: none"> - Firm information arrangement module - Transporter information arrangement module - Vehicle information arrangement module - Driver information arrangement module - Demand request registration module - Bid gathering module 	<ul style="list-style-type: none"> - Transportation tracking-observation module - Transportation current accountment module - Firm analysis reportment module - Transportation /vehicle analysis reporting module - Auction analysis report module 	
3	Development of the software of guidance, track and data administration	<ul style="list-style-type: none"> -GPRS-TCP (General Packet Radio Service - Transmission Control Protocol) port listening software -Vehicle tracking software 	<ul style="list-style-type: none"> - Transportation request registration module - Making an auction module - Bidding examination module - Transportation tracking module 	
4	The software about the bidding, buying, and work order on the given substructure, to be given to personnel/staff	<ul style="list-style-type: none"> - Index -Main menu module - Bidding examination module - Bidding module 	<ul style="list-style-type: none"> - Work order Module - Messaging within the system - Navigation 	
5	Development of the integration software with other associations. (Insurance accountments interface software development)		<ul style="list-style-type: none"> - Insurance accountments 	<ul style="list-style-type: none"> - Banking accountments - Fuel firms

Table 2. Continued

6	Call center support software service		<ul style="list-style-type: none"> - Handling of call - Calling, communicating, messaging - Auction informative - Vehicle tracking 	<ul style="list-style-type: none"> - Supportive services
7	Assembly, integration of the software and devices and the cost of safety analyses		<ul style="list-style-type: none"> - Software installs - Device assemblies 	<ul style="list-style-type: none"> - Systems data analyses - Integration with associations

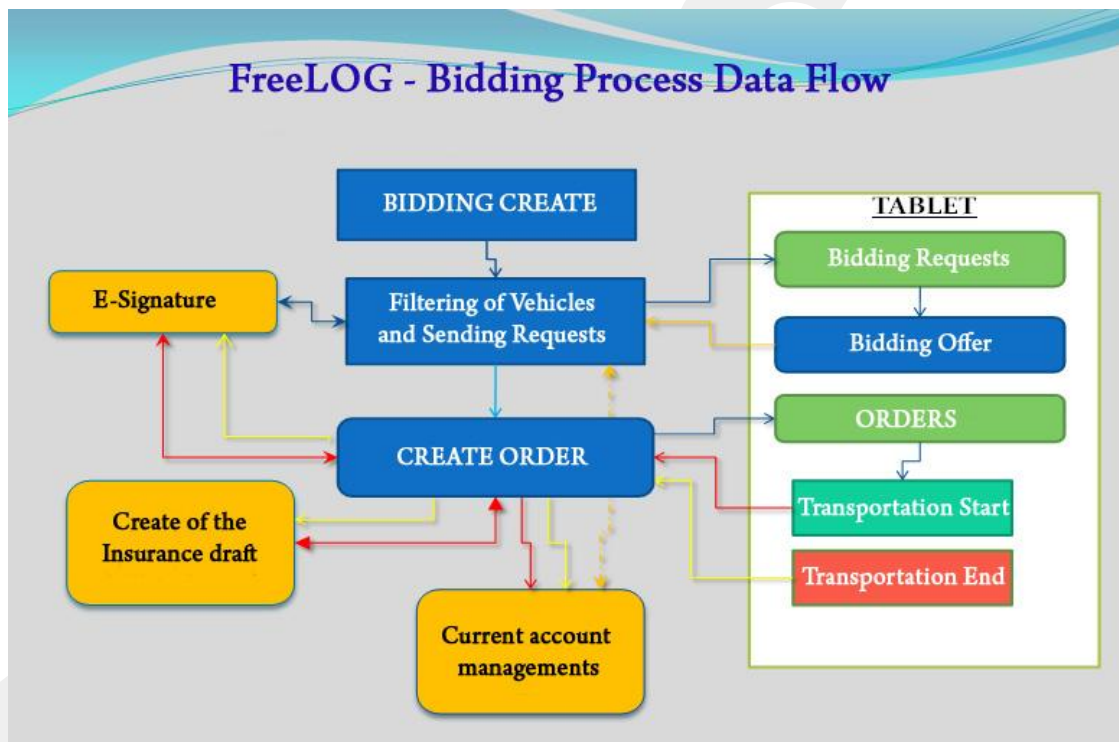

Figure 3. Freelog Bidding Process Data Flow

Web service has been developed which will create auto transport policy and saved into the system at the beginning of transportation.

Figure 3 shown bidding create and offer process data flow

Server Phase (Blue Boxes): Bidding create, filtering of vehicles and sending requests, create order

Tablet Computer Phase (white area): Bidding request, Bidding offer, Orders, Transportation start, transportation end.

Bank Process: Current account managements

Insurance process: Create of the insurance draft

Security process: E-signature

1.3 Determination and Assurance of the Server System Hardware

After determination of necessities and formation the data scheme, hardware items that will constitute the Main Center have been chosen and, formation of databases and information-operation infrastructure analysis has been built. The hardware items determined are given below:

- Server cabinet and assurance of switches,
- Fiber internet connection to data center,
- Structural cable assemblies to staffs work place,
- Assurance of database server,
- Configuration of database server,
- Installation of Microsoft server 2008 operating system,
- Installation of .Net 4.0 frame work,
- Installation of Microsoft Structured Query Language “SQL” 2008 as Database,
- Configuration of telemetric server for vehicle tracking system,
- Installation and testing the needed port listening softwares,
- Installation of the Back-up units,
- Job definitions for SQL servers.

By the following procedures, physical substructure establishment have commenced and feedback of data flow analysis have been accomplished

Information-Procedures technique infrastructure and data flow analysis are;

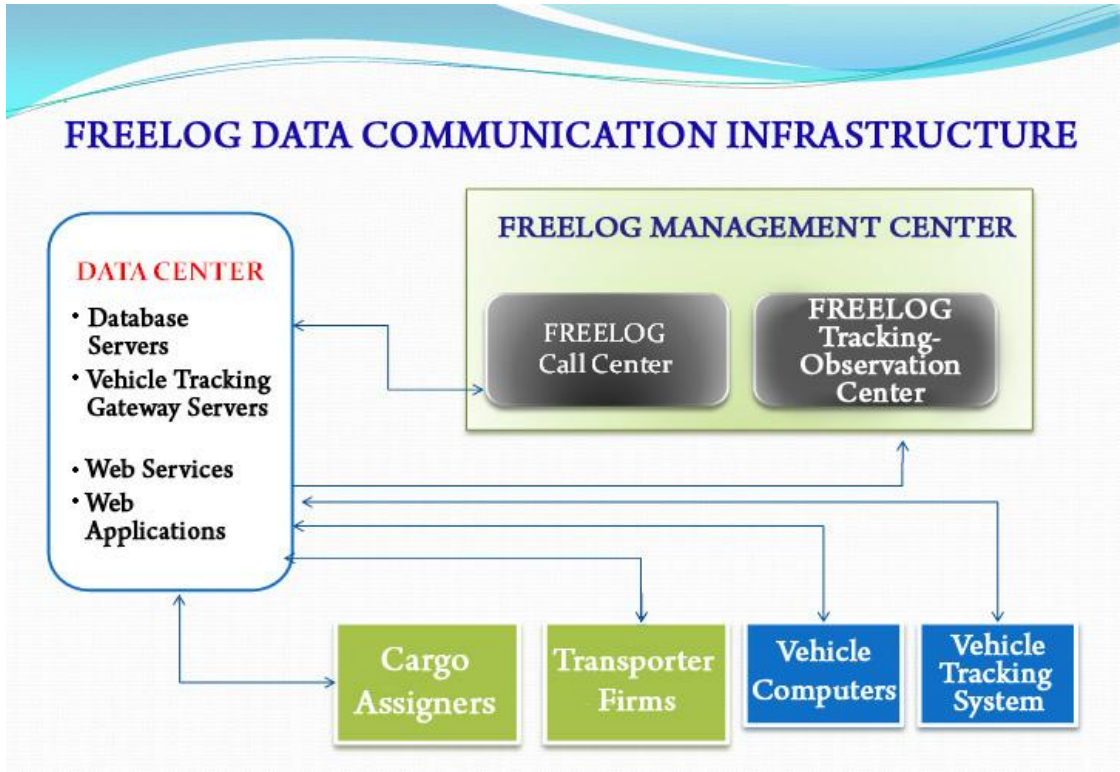

Figure 4. Infrastructure of FreeLog Data Communication

Figure 4 shown cargo assigners, Transporter Firms, Vehicle Computer and Vehicle Tracking System communicated FreeLog management system through data center function of web service and web applications.

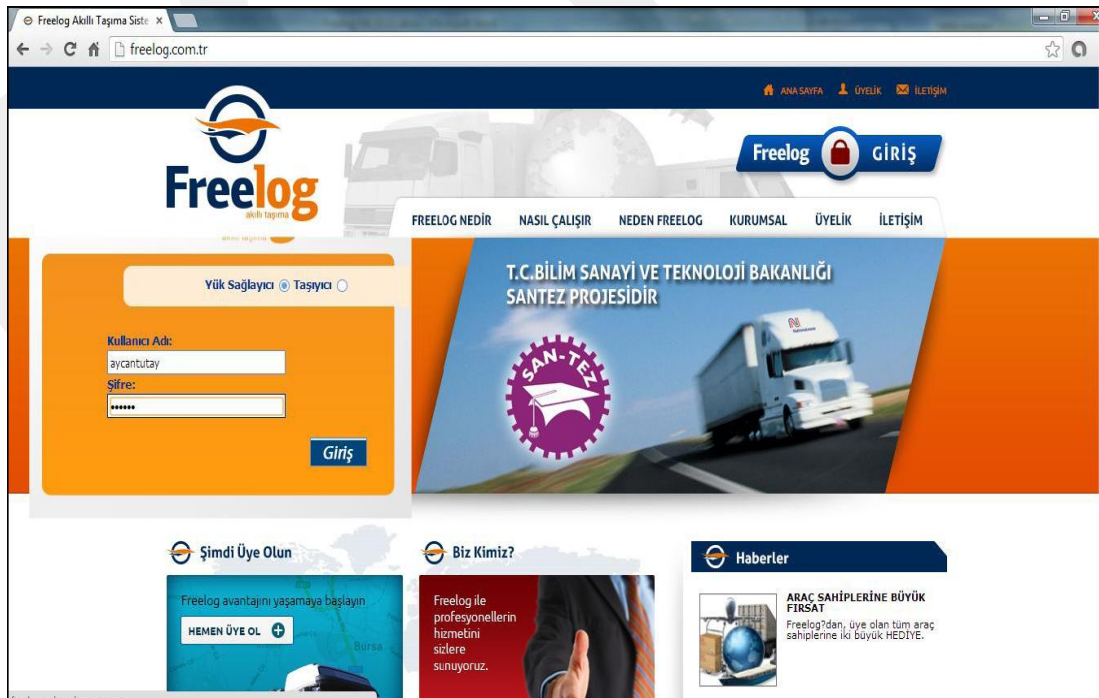

Figure 5. FreeLog Web Site Screen [1]

In Figure 5 displayed sample screen developed for FreeLog website

By executing data flow analysis, administration software development procedure has been started. In this execution package, primarily software functions have been examined and then data flow figure 7 has been initiated.

For definition of Cargo detail web module as Figure 6

By analyzing the functions of demander, transporter and main control center, the necessities have been determined. Throughout these analyses, following software development modules have been established:

- **Definition of cargo specification**

Includes definition of the cargo properties

- ✓ Cargo number and name,
- ✓ Safety type (Material, Dangerous goods, Food, Live animal, Liquid etc.),
- ✓ Transporting Type (Open, Container, Frigofric vehicle etc.).

The screenshot displays the FreeLog web application interface. The browser address bar shows the URL 'freelogweb.sadearge.com/YukTakip.aspx'. The page title is 'FreeLog' and the user is identified as 'Hoşgeldin Hasan ...Konya Şeker Fabrikası A.Ş. 1 [Çıkış, Yapo]'. The main content area features a table with columns for 'İş Emri No', 'Yük No', 'Taşıma Firma', 'Plaka No', 'Yük Alış-İli', 'Yük Teslim-İli', 'Taşıma Bitiş Tarihi', 'İş Emri Durumu', and 'Harita'. Below the table is a 'Yük Detay Bilgileri' section with various input fields for cargo details. At the bottom, there is a copyright notice '2013 © Copyright by [SADE ARGE]' and a Windows taskbar.

İş Emri No	Yük No	Taşıma Firma	Plaka No	Yük Alış-İli	Yük Teslim-İli	Taşıma Bitiş Tarihi	İş Emri Durumu	Harita
14	38	KOBI Lojistik A.Ş.	20 AFF 67	Antalya	İzmir		Yüklendi	
13	9	KOBI Lojistik A.Ş.	42 KB 4202	Konya	İzmir		Kayıt	

Yük Detay Bilgileri			
Başlama Tarihi:	Bitiş Tarihi:	Açıklama:	
Şoför Adı Soyadı: Ali Aydın	Taşıma Mesafesi: 555	Taşıma Fiyatı:	
Yük Tipi: Kuru Yük	Yük Türü: Gıda	Yük Cinsi: Tahıl	
Ambalaj Türü: Torba	Yük Tonajı: 12000	Araç Kasa Türü: Açık	
Yük Alış Adresi: Tekbaş Fabrikası	İlçe/İl: Karatay/Konya	Ülke: TÜRKİYE	
Yük Teslim Adresi: Migros	İlçe/İl: Naridere/İzmir	Ülke: TÜRKİYE	
Yükleme Süresi: 252	Boşaltma Süresi: 203		

10	15	FEM Lojistik	45 VS 1234	Afyon	Afyon	25.01.2013	Boşaltıldı	
9	15	FEM Lojistik	45 VS 1234	Afyon	Afyon		Yüklendi	
8	9	KOBI Lojistik A.Ş.	42 KB 4202	Konya	İzmir		Kayıt	
7	9	KOBI Lojistik A.Ş.	42 KB 4202	Konya	İzmir	07.02.2013	Boşaltıldı	

Figure 6. FreeLog Cargo Definition Screen Details [1]

- **Firm information definition module**

Includes Definition of the Demander producers and firm informations to the system:

- ✓ Firm identity information (Reputation, Tax number, Business background, Address, Telephone, Bank account numbers, E-mail, Web etc.),
- ✓ Firm owner informations (Name, Occupation, Reputation, Telephone, E-mail, Partnership condition),
- ✓ Authorized staff (Name, Reputation, Authorization, Telephone, E-mail etc.),
- ✓ Working area (Producers, Provisioners, Products),
- ✓ Cargo capacity (Cargo types, Cargo commence and completion spots, Transportation types etc.).

- **Transporter information definition module**

Definition of the Carrier firms-persons information into the system

- ✓ Firm-Person identity information (Name- Surname, Identity Number, Address, Phone number, Bank account numbers, E-mail, Web etc.),
- ✓ Transporting capacity (Cargo type, Possible cities, Transporting types etc.),
- ✓ Firm of vehicles (License plate, Ownership status, Work status etc.),
- ✓ Firm of drivers (Identity informations, Driver license informations, Ownership status, Work status etc.),
- ✓ Authorized persons (Name-Surname, Title, Clearance, Phone number, E-mail etc.).

- **Vehicle information definition module**

Definition of the transporter vehicle information into the system:

- ✓ Vehicle information (License plate, Vehicle owners, Type, Brand, Model, Registration date etc.),
- ✓ Transporting potential (Types of cargo, Cargo capacity, Possible cities, Transporting type etc.),
- ✓ Vehicle registration process (Mechanical check informations, Traffic insurance, Vehicle insurance, Tax etc.),

- ✓ Vehicle accident informations (Date, Place, Damage, Fault, Driver, Event, Decision, etc.),
 - ✓ Vehicle traffic violation fine information (Date, Place, Driver, Kind of fault, etc.),
 - ✓ Consumables (Tires, Oil, Fuel etc.).
- **Definition of the drivers information into the system:**
 - ✓ Personal Informations (Name-Surname, Identity number, Driver license, Address, Phone number, E-mail etc.).
 - **Definition of the insurance information module**
 Definition of the cargo insurance information into the system:
 - ✓ Insurance company information (Title, Address, Phone number, E-mail etc.),
 - ✓ Draft Types.

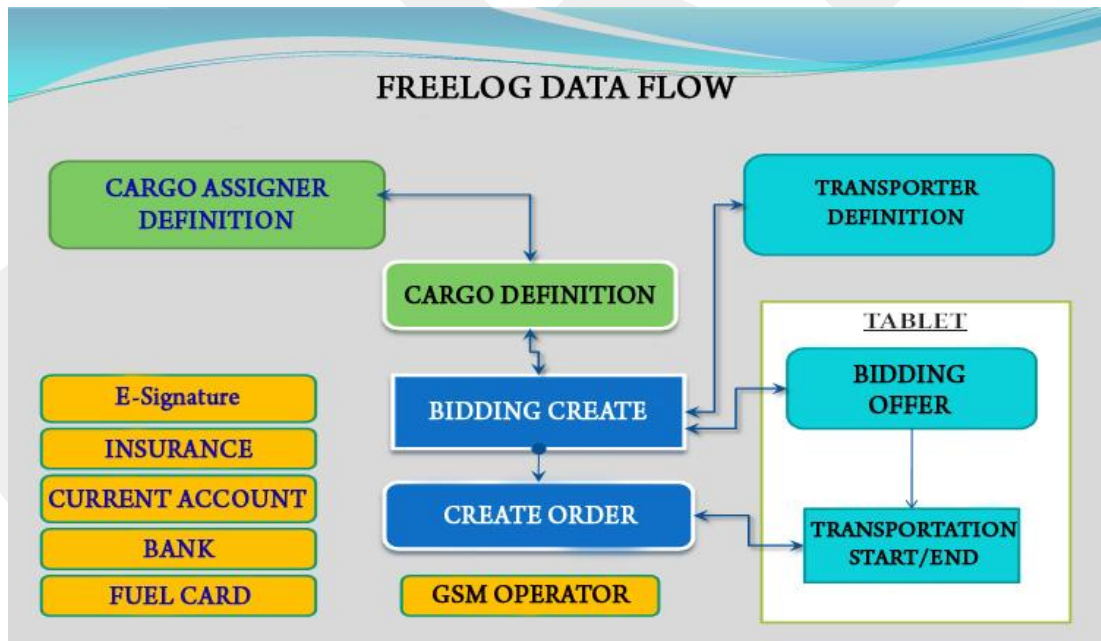

Figure 7. Freeelog Data Flow

Figure 7 shown bidding and order process relations.

1.4 Definition and Assurance of the Call center Hardware

For forming the infrastructure of the hardware of the Freelog callcenter system operators, supplying the necessary equipment for execution and operation of the relevant operations, the following studies have taken place:

- Analyzing the callcenters capacity, function and duty,
- Assurance of the necessary servers and client computers,
- Assurance of the phone switchboard system for the call center,
- Installation Windows Server 2008 operating system to the server computer,
- Installation of the user licenses of the remote desktop,
- Communication between the client computer and Freelog administration software has been done via settings on the server,
- Call center operators work environment has been prepared,
- Operator equipment and Customer Relationship Management “CRM” based call center server have been provisioned,

Entire systems are presented in the prototype call center of Çankaya University

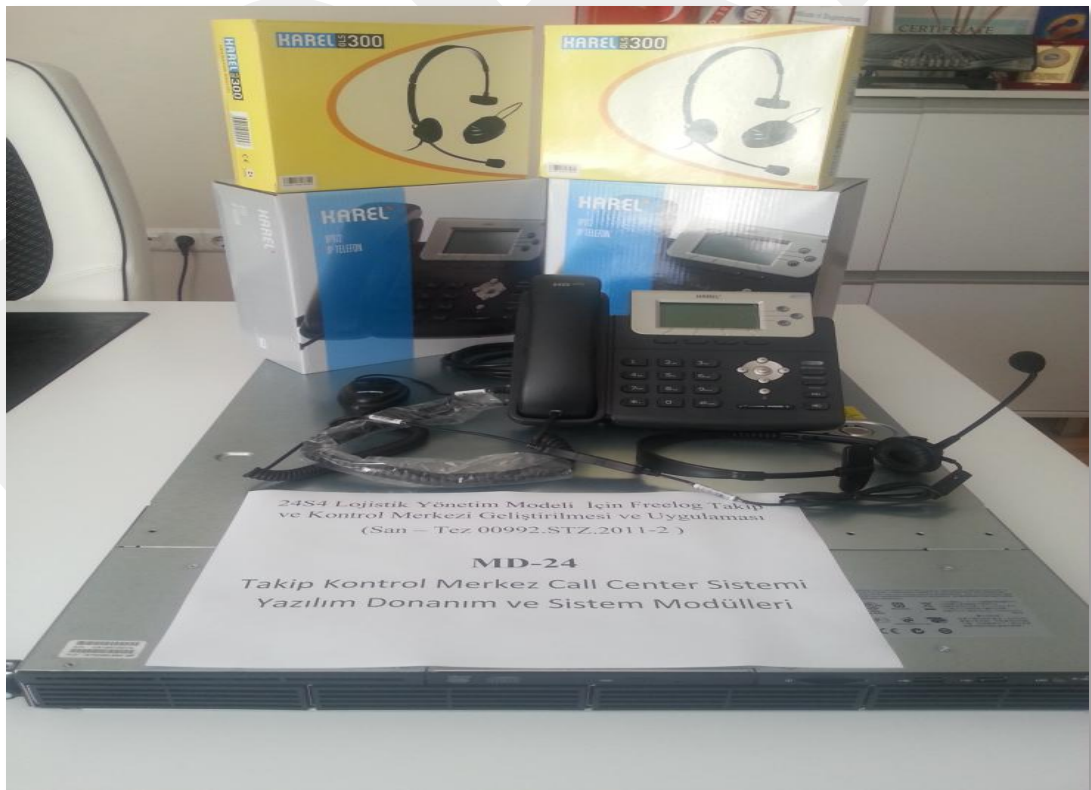

Figure 8. Freelog Call center Personnel Hardware

Freelog Call center personnel hardware are shown in Figure 8.

CHAPTER 2

In this chapter, development of callcenter software, systems web control software and equipment needed for the transporter vehicles assurance have been discussed.

2.1 The Necessary Web System Needed for the Applicant Transporter Firms Administration to the System

Softwares of the web based cargo supplier and transporter firms within this business package are analyzed and so the needed modules are determined. Throughout these analyses, the Freeelog internet based software is developed.

Developed WEB software modules and their index:

- **Firm information arrangement module**

The module helps firms and cargo assigners to make arrangements about their institutional information;

- ✓ Firms identity informations (Address, Telephone, Bank account number, E-mail etc.),
- ✓ Firm owners information (Name, Occupation, Reputation, Telephone, E-mail, Partnership status),
- ✓ Authorized staff (Name, Reputation, Authority, Telephone, E-mail etc.)
- ✓ Subjects (Producers, Provisioners, Products etc.),
- ✓ Cargo capacity (Cargo types, Loading and Delivery centers, Transportation types etc.).

- **Transporting request record module**

Includes firms' definition of the request:

- ✓ Request opening Information (Request number, Date, Firm, Bids partners, Predicted cost, Payment time and form, Loading, Transportation, Delivery conditions etc.),
- ✓ Cargo information (Type of the cargo, Amount, Packing, Transportation type etc.),

- ✓ Transportation information (Transportation number, Load-delivery dates, Amount, Type of vehicle, Price range).
- **Offer gathering module**
Includes Transporter firms' /peoples offers to the proclaimed auctions:
 - ✓ Offer registration (Auction Number, Vehicle information, Driver information),
 - ✓ Offer conditions (Amount, Price, Date, Duration),
 - ✓ Vehicle condition (Location, Capacity, Function).
- **Vehicle tracking module**
Includes Procedures of the firms' cargo:
Vehicle tracking module screen are shown in Figure 9.
 - ✓ Cargo registration (Transportation number, Date, Hour, Vehicle number, Driver number, Location, Deliverer, Sender),
 - ✓ Cargo tracking (Vehicles Location, Transportation initiation, Voyage condition, Transportation duration),
 - ✓ Cargo delivery registration (Transportation number, Date, Hour, Location, Deliverer, Sender, Condition of the cargo, Declaration of the damage, Approval-Reject).
- **Firm analysis reporting module**
Includes Reports of the firms' transported trades
 - ✓ Requested jobs (Date, type of cargo, Amount, Price),
 - ✓ Trades on progress (Auction, Vehicle, Type of the cargo, Amount, Price, Duration, Progress Condition),
 - ✓ Completed transporting (Auction, Vehicle, Type of the cargo, Amount, Price, Duration, Conclusion),
 - ✓ Current account procedures.

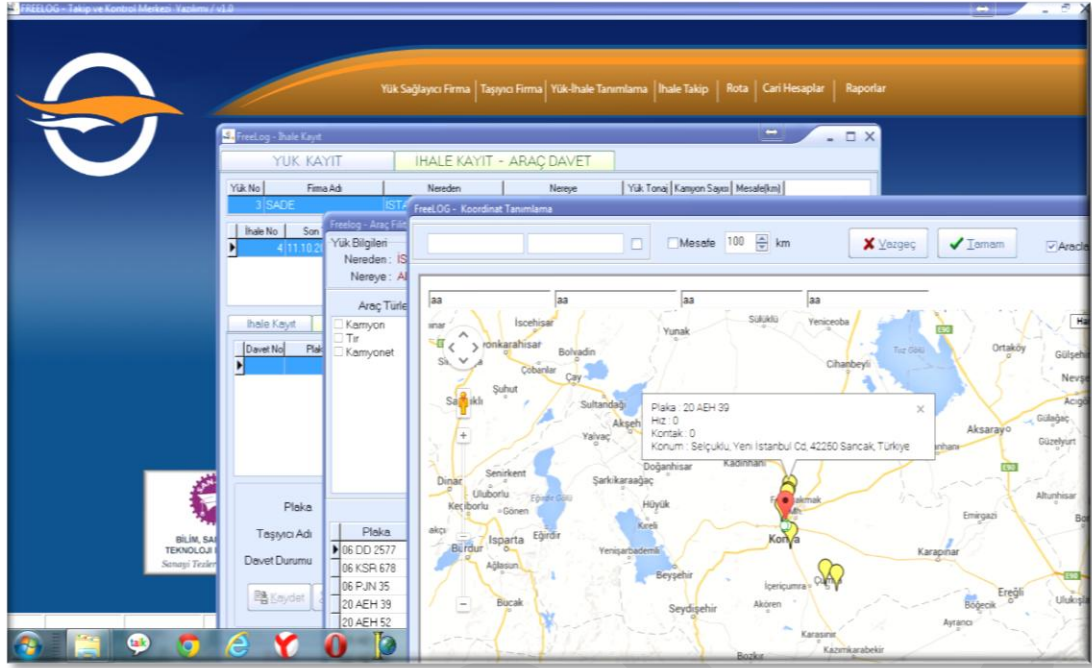

Figure 9. Freelog Vehicle Tracking Screen[1]

2.2 Development of the Software of the Mobile Tablet Used for Consideration of the Open Auctions on the System (Android Based) for the Transporter Vehicle Owners

- **Transporter information arrangement module**

Includes Transporter Firms' / Peoples to arrange their own information:

- ✓ Firms' / Peoples identity information (Address, Telephone, Bank account numbers, E-mail, Web etc.),
- ✓ Transportation capacity (Cargo types, Possible cities, Transportation forms etc.),
- ✓ Firms' vehicles (Plate Number, Ownership status, Function etc.),
- ✓ Drivers of the firm (Identity information, Driver license information, Ownership status, Function etc.),
- ✓ Authorized staff (Name, Reputation, Authority, Phone number, E-mail etc.),

- **Vehicle information arrangement module**

Includes the arrangement of the information of the transporter

- ✓ Vehicle information (License plate, Vehicle owners, Type, Brand, Model, Registration date etc.),

- ✓ Transportation capacity (Cargo types, Capacity, Possible cities, Transportation types etc.),
- ✓ Vehicle registration procedures (Mechanical check informations, Vehicle insurance, Taxes etc.),
- ✓ Vehicle accident information (Date, Location, Damage, Fault, Driver, Issue, Decision etc.),
- ✓ Vehicle Accident Fine Informations (Date, Location, Driver, Fault type, Fines etc.),
- ✓ Consumables (Tires, Oil, Fuel etc.),

- **Driver information arrangement module**

Includes Transportative vehicles' drivers information arrangements:

- ✓ Personal information (Address, Telephone, E-mail etc.),
- ✓ Driver licence information (Type, Licence date etc.),
- ✓ Firms in the history (Firm name, Date, Working conditions etc.),
- ✓ Insurance information (Type, Insurance number, Initiation date, Duration, Condition etc.),
- ✓ Health condition (General health information, Medications, Prosthesis etc.),
- ✓ Interests (Sports, Voyage, Shopping, Social media, Art etc.),
- ✓ Membership (Associations, Clubs, institutions etc.).

- **Transportation current account module**

Includes Payment and revenue registrations of the transportations:

Transportation Current Account Module screen are shown in Figure 10.

- ✓ Payment informations (Firm, Request number, Date, Cost, Revenue type etc.),
- ✓ Payment type (Transportation number, Date, Cost, Type of payment, Account number).

- **Transportative / Vehicle analysis reporting module**

Includes transportatives / Vehicles transported reports

- ✓ Bids (Date, Auction number, Price, Auction condition),

- ✓ Completed auctions (Date, Type of transportation, cost, price),
 - ✓ Completed jobs,
 - ✓ Current account procedures.
- **Auction analysis reporting module**
 - Includes opened auctions information reports:
 - ✓ Bidding conditions (Preparing, Bid Gathering, Initiation, completed, cancel, Delay, Damage etc.),
 - ✓ Auction analysis via firms,
 - ✓ Auction analysis via cargo types,
 - ✓ Auction analysis via transporters,
 - ✓ Auction analysis via cities.

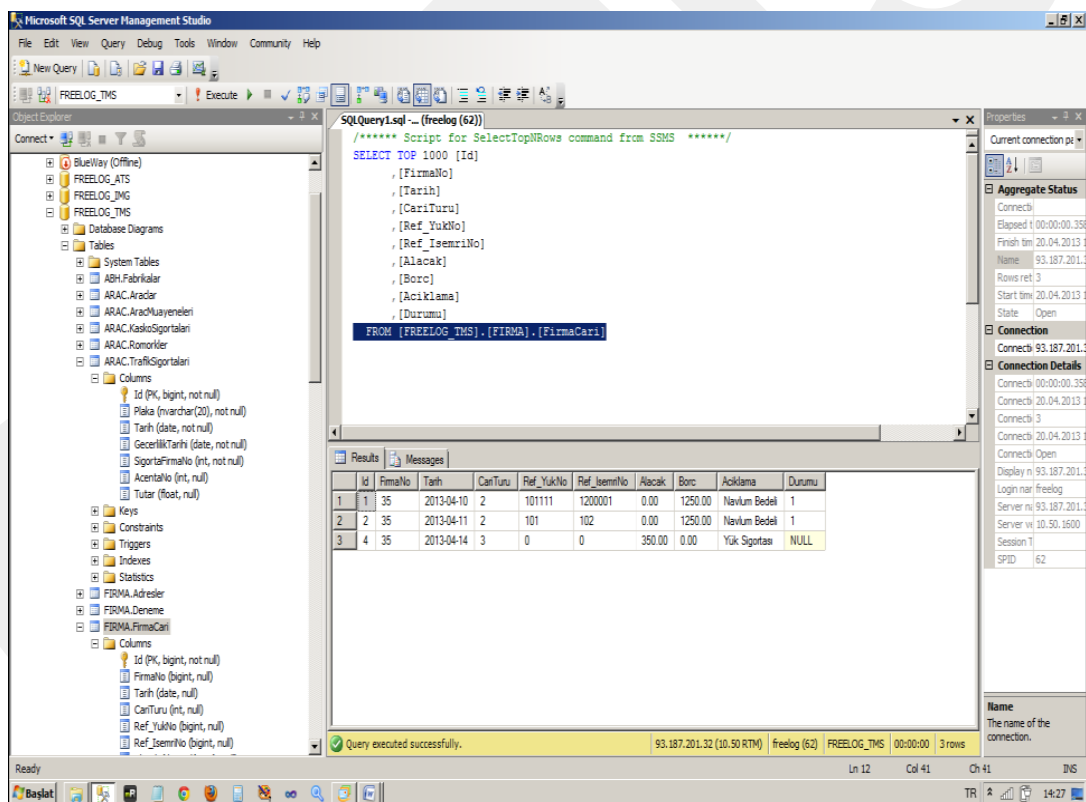

Figure 10. Freeleg SQL Server Database Current Account Screen

2.3 Providing of Necessary Hardware for Data Transmission to Transporter Vehicle

With examining vehicle tracking system within the scope of work package, device characteristics are set and assured for prototype application. Also the qualifications and functions of vehicle computer which will be used by driver are analyzed and devices are integrated with the relevant systems in other work packages.

Figure 11 is being used to track auctions and to bid. It has 2 sim slots on it and it can connect to the internet With GPRS system by itself. As seen in Figure 14 it being used for written internal system messaging, vocal (telephone calls) and to communicate with the “call center-operator personnel” and to perform software functions such as bidding, transportation, delivery through Freelog software installed on it. Tablet PC software functions are discussed in detail in chapter 3.



SON TEKLİF TARİHİ	NEREDEN	NEREVE	MESAFE	YUK CİNSİ	FİRMA ADI
11/19/2012 12:00:00 AM	Konya	İzmir	590	1	Arçelik A.Ş.
11/20/2012 12:00:00 AM	Balıkesir	İstanbul	320	1	Beko
11/19/2012 12:00:00 AM	Balıkesir	İzmir	280	1	Beko
0			0	0	
11/20/2012 12:00:00 AM	Balıkesir	İstanbul	320	1	Beko

Figure 11. Freelog Mobile Computer

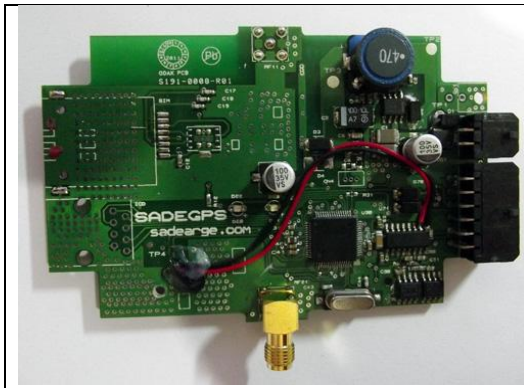

Figure 12. Freelog GPS Vehicle Tracking Module Top Side

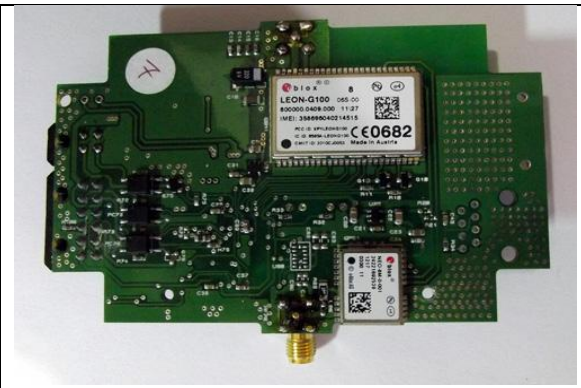

Figure 13. Freelog GPS Vehicle Tracking Module Bottom Side

Vehicle tracking system mounted on the vehicle is used to send the position information of the vehicle via GPRS system after receiving them from satellite and is shown in Figure 13 and 14.

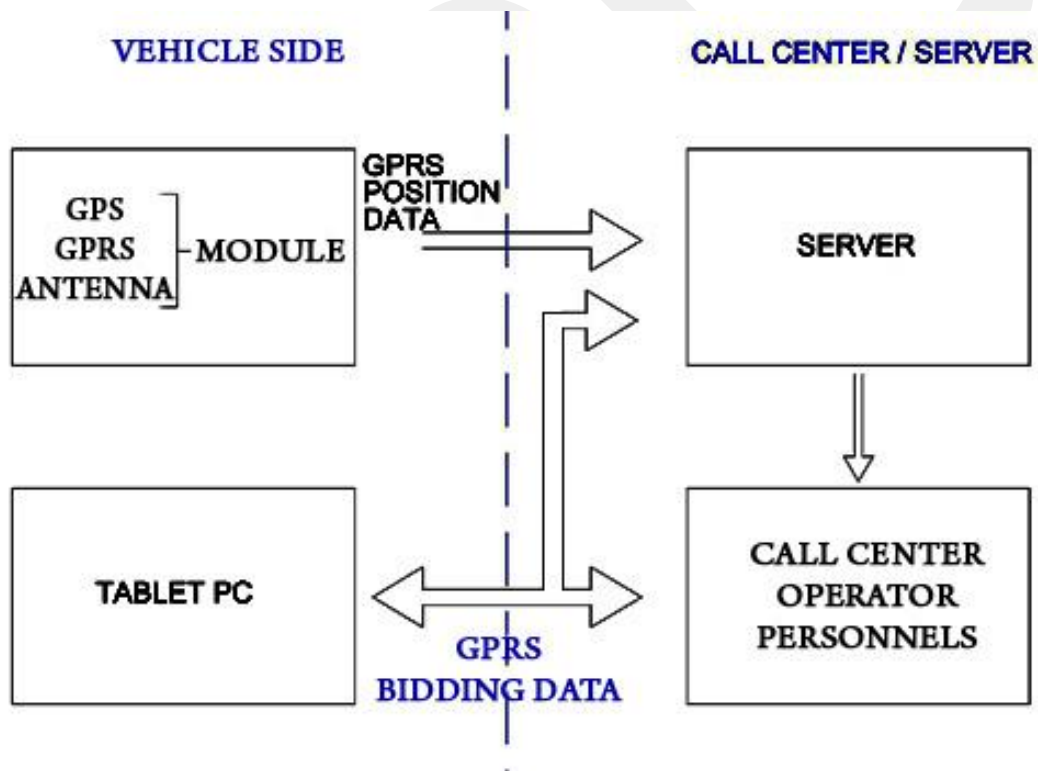

Figure 14. General Communication Structure

As seen in general communication infrastructure (Figure 14) GPS signals are sent to the server via GPRS after receiving them with the vehicle tracking equipment, the server determines the auctions in the surrounding area which it may be involved in based on the vehicles position information, if it is in the cargo carrying position it delivers the information such as route and speed to the operator and system administrators by following the position information.

CHAPTER 3

In this section, software on the device developed for transporter tools has been created which enable receiving work order, tendering, communicating with the drivers, developing software, and entering the cargo records of suppliers, also entering the price offers into the system with conformance.

In this section we include the necessary software analyses and created modules, which are listed below:

- **Login screen, which lets user login to system securely (shown in Figure 15).**
 - ✓ User name, Password, Security code (Short Message Service “SMS” etc.),

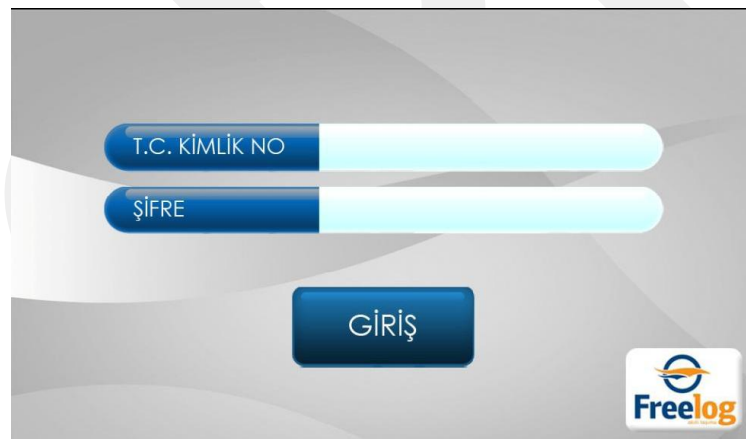

Figure 15. Vehicle Computer Unit Login Screen

- **Main menu module**
 - ✓ Vehicle condition (Full, Empty, In service, Out of service etc.),
 - ✓ Navigation,
 - ✓ Work order,
 - ✓ Bidding information
 - ✓ Internal messaging system,
 - ✓ Bidding examination module (shown in Figure 16),
 - ✓ Continued bidding list,
 - ✓ Bidding detail information (shown in Figure 17),

- ✓ Bidding decision declaration (Offer, Indifference, and Request to contact).



Figure 16. FreeLog Vehicle Computer Bidding Detail Information Screen



Figure 17. Vehicle Computer Bidding Examination Screen

- **Bidding offer Module**
 - ✓ Offer, automatic offer options,
 - ✓ Bidding conditions approval, express an opinion.
- **Work order module**
 - ✓ Received work order list,
 - ✓ Work order detail information (Address, Cargo, Date, Time, Contact),
 - ✓ Work order realization process (Start, Transition, Cargo received, Delivered, Canceled, Closed etc.),
 - ✓ Skip to navigation.

- **Messaging within the system**

Includes the communication between call center and driver:

- ✓ Message receiving, Answering, Send a new message.

- **Navigation**

- ✓ Find address,
- ✓ Assignment of route, Alternate route,
- ✓ Distance estimation.

- **Transporting request record module**

Includes the companys transporting request form definition:

- ✓ Claim create informations (Request number, Date, Firm, Request receiver-approving person, Estimated price, Time of payment-payment type, Loading-transporting delivery conditions etc.),
- ✓ Cargo informations (Cargo type, Amount, Package, Transporting type etc.),
- ✓ Transporting informations (Transporting number, Receive –Deliver dates, Amount, Type of vehicle, Price range etc.).

- **Transporting tracking–observation module**

Includes operations made on the carried goods during transportation by the company:

- ✓ Cargo register (Transporting number, Date, Vehicle number, Driver number, Place, Receiver staff, Deliverer),
- ✓ Cargo tracking (Vehicle position, Start time of transportation – Current condition, Transporting duration),
- ✓ Record of receipt (Transporting number, date, place, Deliverer, Receiver-approver, Cargo condition, Declaration of the damage, Delivery Accept-Reject).

CHAPTER 4

In this Chapter we describe how we have chosen the GPS system to determine the position of the vehicle with certain accuracy and stability with a reasonable cost; how we have developed the software to acquire data from the GPS system, and how we have reduced the data and developed the test procedure and scenario to test and verify the accuracy of the positions of the vehicle in comparison with some reference data that we obtained from the public institutions. We showed that the GPS system chosen was accurate and stable enough in determining the position of vehicle in static and dynamic conditions.

We have tested the FREELOG System as a whole to verify if the hardware and software integration had been achieved properly. The server apparatus and equipment were installed and data input-output tests were conducted. The data transfer from the GPRS Subsystem to the server of the FREELOG System was tested.

Further, the following functional tests have been performed to verify:

- If the cargo assigner can start the auction process,
- If the load registration is performed,
- If the carrier company is registered,
- If the vehicle registration and tablet assignment to the vehicle are done,
- If the cargo offer is carried out from the tablet PC,
- If the offer is approved and the work order is given to the vehicle that won the bidding.

4.1 National Marine Electronics Association (NMEA) Protocols

GPS receiver communication is defined within this specification. Most computer programs that provide real time position information use and expect data to be in the NMEA format. This data includes the complete position, velocity, time (PVT) solution computed by the GPS receiver. The idea of NMEA is to send a line of data

called a sentence that is totally self contained and independent from other sentences. There are standard sentences for each device category and there is also the ability to define proprietary sentences to be used by the individual company. All of the standard sentences have a two-letter prefix that defines the device. For GPS receivers the prefix is GP, which is followed by a three-letter sequence that defines the sentence contents. In addition, NMEA permits hardware manufacturers to define their own proprietary sentences for whatever purpose they see fit. All proprietary sentences begin with the letter P and are followed with 3 letters that identify the manufacturer controlling that sentence [2].

4.1.1 NMEA 2.0 Sentences

NMEA Standards have been upgraded with the technology improvements and the new requirements emerged through the years. NMEA 2.0 is the standard that supports our GPS chip (module) of NEO-6M type. In this standard each sentence begins with a '\$' and ends with a carriage return/line feed sequence and can be no longer than 80 characters of visible text (plus the line terminators). The data is contained within this single line with data items separated by commas. The data itself is just American Standard Code for Information Interchange (ASCII) text and may extend over multiple sentences in certain specialized instances but is mostly fully contained in one variable length sentence. The data may vary with the level of precision of the message. For example, time might be indicated to decimal parts of a second or location may be shown with 3 or even 4 digits after the decimal point. Programs that read the data should only use the commas to determine the field boundaries and are not depended on column positions. There is a provision for a checksum at the end of each sentence which may or may not be checked by the unit that reads the data. The checksum field consists of a '*' and two hexadecimal digits representing an 8 bit EXCLUSIVE OR of all characters between, but not including, the '\$' and '*'. A checksum is required on some sentences [2].

NEO-6M type module of U-Blox Company which is used in this project presents the measurement results in the form of NMEA 2.0 sentences. NMEA sentences contain various data types. The module we used in this project supports only the following 6 types of sentences:

- \$GPGSV** GPS Satellites in view,
- \$GPGLL** Geographic position, latitude / longitude,
- \$GPRMC** Recommended minimum specific GPS/Transit data,
- \$GPVTG** Track made good and ground speed,
- \$GPGGA** Global Positioning System Fix Data,
- \$GPGSA** GPS DOP and active satellites[2].

When selecting the sentences, the data needed in the project, and its storability and workability are considered. We selected the GPRMC sentence from the 6 sentences given above that satisfies this. The other sentences either miss some data or contain data that are not necessary regarding the project requirements.

4.1.2 GPRMC Sentence properties

The sample data sequence shown in Table 3 identifies the data parts when a sentence is decomposed. Table 4 describes the meaning of each data part. Each sentence contains different combinations of data parts. Utilizing this, NEO-6M module can be customized in accordance with the purpose.

Table 3. GPRMC Data Parts

Data:	\$GPRMC, 123519, A, 4807.038,N, 01131.000,E, 022.4, 084.4, 230394, 003.1, W, *6A									
Field:	1	2	3	4	5	6	7	8	9	10

Table 4. GPRMC Data Structure

Field Number	Field Mean
1	Recommended Minimum sentence C
2	123519 Fix taken at 12:35:19 UTC
3	A Status A=active or V=Void
4	4807.038,N Latitude 48 deg 07.038' N
5	01131.000,E Longitude 11 deg 31.000' E
6	022.4 Speed over the ground in knots
7	084.4 Track angle in degrees True
8	230394 Date - 23rd of March 1994
9	003.1,W Magnetic Variation
10	*6A The checksum data, always begins with *

From Table 4 we used only the data parts that are related to latitude (4), longitude (5) and speed over ground (in knots, i.e., nautical miles per hour) (7) values.

Data parsing and convert operations are also performed in the FREELOG System. However, since they belong to the scope of software engineering performed by the system server, we did not carry out these functions here.

4.1.3 GPGGA Sentence properties

The most important NMEA sentences include the GGA which provides the current Fix data, the RMC which provides the minimum GPS sentences information, and the GGA which provides the Satellite status data. Table 5 and table 6 show GPGGA data parts and GPGGA data structure [2].

Table 5. GPGGA Data Parts

Data:	\$GPGGA, 123519, 4807.038,N, 01131.000,E, 1, 08, 0.9, 545.4,M, 46.9,M, , ,*47											
Field:	1	2	3	4	5	6	7	8	9	10	11	12

Table 6. GPGGA Data Structure

Field Number	Field Mean
1	GGA Global Positioning System Fix Data
2	123519 Fix taken at 12:35:19 UTC
3	4807.038,N Latitude 48 deg 07.038' N
4	01131.000,E Longitude 11 deg 31.000' E
5	Fix quality: 0 = invalid 1 = GPS fix (SPS) 2 = DGPS fix 3 = PPS fix 4 = Real Time Kinematic 5 = Float RTK 6 = Estimated (dead reckoning) (2.3 feature) 7 = Manual input mode 8 = Simulation mode
6	08 Number of satellites being tracked
7	0.9 Horizontal dilution of position
8	545.4,M Altitude, Meters, above mean sea level
9	46.9,M Height of geoid (mean sea level) above WGS84 ellipsoid
10	(empty field) time in seconds since last DGPS update
11	(empty field) DGPS station ID number
12	*47 the checksum data, always begins with *

4.2 Selective Availability (SA)

Selective availability (SA) is a degradation of the GPS signal with the objective to deny providing full position and velocity accuracy to unauthorized users by dithering the satellite clock and manipulating the ephemerides. When SA is on, the fundamental frequency of the satellite clock is dithered, so that the GPS measurements are affected. The broadcast ephemerides are manipulated so that the computed orbit will have slow variations. Several levels of SA effects are possible. The SA is enabled on Block II satellites and on the more modern satellites.

The authorized users may recover the not degraded data and exploit the full system potential. For doing so they must possess a key that allows them to decrypt correction data transmitted in the navigation message. For the high-precision users, International Global Navigation Satellite System (GNSS) Service (IGS) precise orbit

and forecast orbit data may be used. Using known positions (or monitor stations), the range corrections can be computed. Differential GPS may also eliminate at least a part of the SA effects [3].

4.3 Standard Positioning Service (SPS)

The SPS is available free of direct charges to all users worldwide. There are no restrictions on SPS usage. This service is specified to provide accuracies of better than 13m (95%) in the horizontal plane and 22m (95%) in the vertical plane (global average; signal-in-space errors only). Universal Time Coordinated (UTC) United States Naval Observatory (USNO) time dissemination accuracy is specified to be better than 40 ns (95%).

SPS measured performance is typically much better than the specification. At the time of this study, the SPS was the predominant satellite navigation service in use by millions of people in the World [4].

4.4 Dilution of Precision “DOP”

The concept of dilution of precision (DOP) was an originated with users of the Loran-C navigation system. The idea of Geometric DOP is to state how errors in the measurement will affect the final state estimation. This can be defined in

$$GDOP = \frac{\Delta \text{ Output Location}}{\Delta \text{ Measured Data}} \quad (1.1)$$

Conceptually, one can imagine errors on a measurement resulting in the $\Delta(\text{Measured Data})$ term changing. Ideally small changes in the measured data will not result in large changes in output location. The interpretation of this formula is shown in Figure 18. It indicates two possible scenarios with acceptable and poor Geometric Dilution of Precision (GDOP) [5].



Figure 18. Good and Poor DOP States

4.5 Performing the Tests

We first examined the data formats from the GPS system and the technical features of the hardware (GPS module and active antenna) of the system to check if they comply with the design configuration.

Then we developed a test software to test the GPS module whether it is receiving the GPS signal from the satellites, sending the data through the normal channel to the server properly.

Then we developed a test setup with a laptop computer containing testing software that receives the data coming from the GPS module and stores into a file within the Microsoft Access Database (MDB) in the laptop computer. In the actual system the data from the GPS module is sent to the SQL database in the system server.

We first tested the GPS module statically, by using a reference point whose address is also given by the Google Earth and by also the City Hall.

Then we tested the system dynamically. We determined a test route for the vehicle on the move carrying the GPS module. The test route coordinates were obtained from the Google Earth first, then from the City Hall. We converted the Google Earth coordinate into latitude and longitude values. We took this as our first reference data to compare with the data to be obtained from the GPS module.

Then we drove the vehicle on this test route while recording the data from the GPS module.

We then compared the data received from the GPS module with our reference data, which was obtained by converting the Google Earth data as explained. We assumed that the Google Earth coordinate data was correct.

The driver kept the lines indicated on the road and was very careful about not violating the route when driving the vehicle. Therefore it was made sure that if there

is a difference between the data coming from the GPS module and the data from our reference, it should be originated from the GPS data errors.

4.5.1 Test software

GPS module sends position data at a rate of 1 Hz, creates a record in every second and assigns an identity definition “ID” for each new record. The test software writes these data coming from serial port to Microsoft Access Database with “MDB” extension from the moment it starts receiving data from the port assigned.

In this case, each data received while on the move is one second later than the previous position data. The driver tried to keep the speed constant at 30 km/h on the test route. Since we get the position data (longitude and latitude and the time they were taken) at each second, the velocity of the vehicle can also be calculated.

The related interface screen for GPS data recording is shown in Figure 18. The combo box seen on Figure 19 allows the user to select the computer’s serial port from the 4 com ports available. The “Connect” button runs the connection procedure to connect the chosen port when clicked. The “Instant GPS Data” memobox on the Interface shows the current real-time GPS data for a period until the next GPS data comes. ”The GPS records” memoboxs shows the data written in Table 1 area

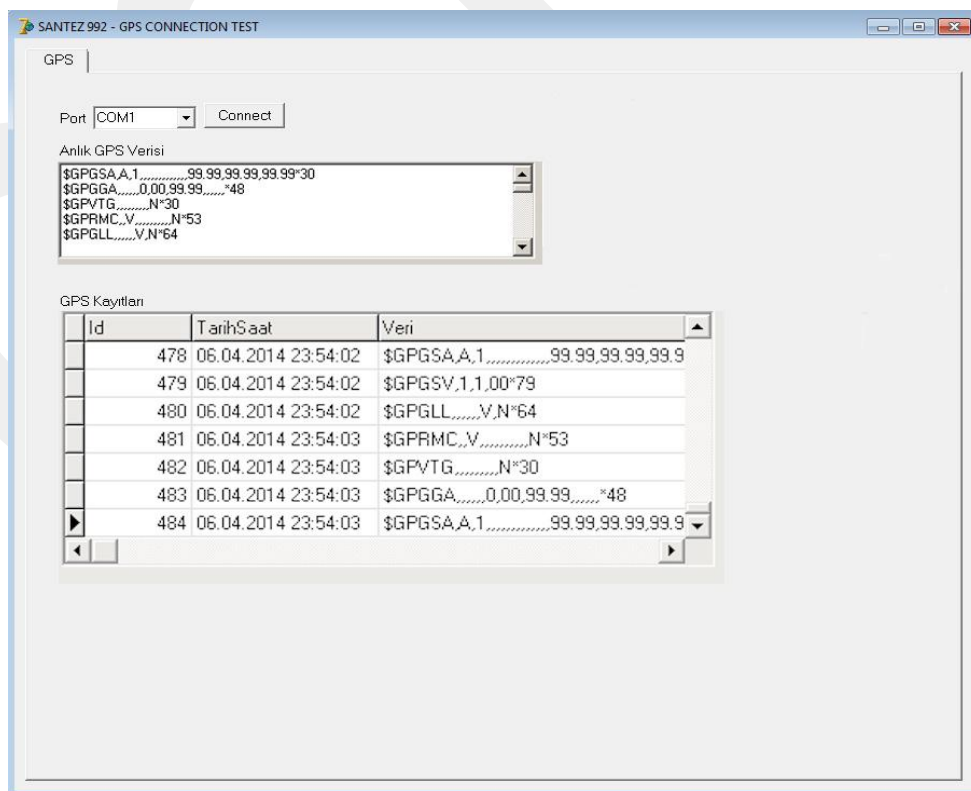

Figure 19. Test Software Interface

4.5.2 Test software code

The test software is developed and compiled with Delphi 6.0 in accordance with the flow chart given in Figure 20.

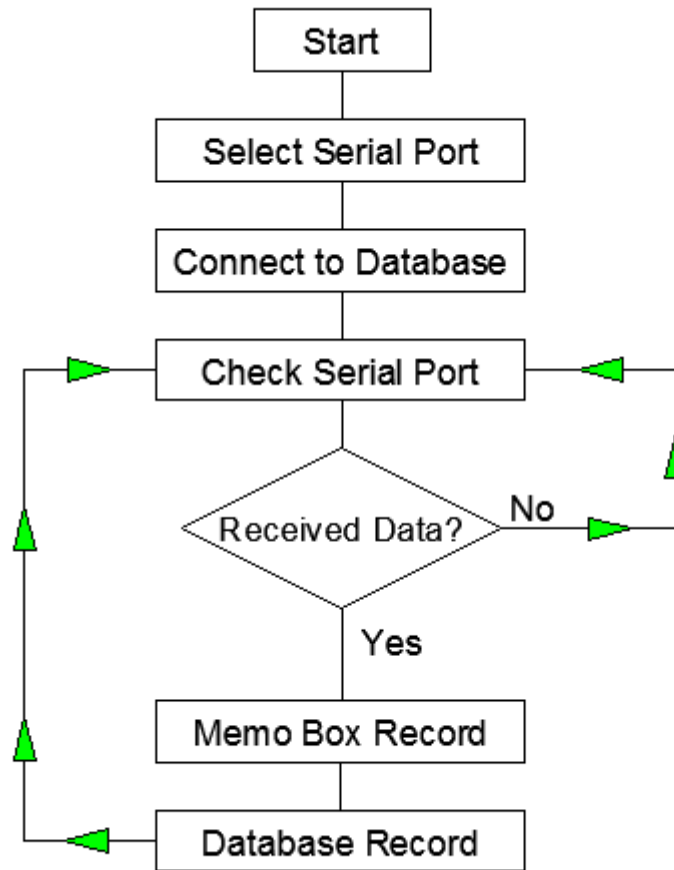

Figure 20. Test Software Flow Chart

```
unit GPS_ConnUnit1;  
interface  
uses  
  Windows, Messages, SysUtils, Variants, Classes, Graphics, Controls, Forms,  
  Dialogs, StdCtrls, ComDrv32, DB, ADODB, Grids, DBGrids, LMDControl,  
  LMDBaseControl, LMDBaseGraphicControl, LMDGraphicControl,  
  LMDLEDCustomLabel, LMDLEDLabel, ComCtrls, ExtCtrls, TeeProcs,  
  TeEngine,  
  Chart, DbChart;  
type
```

```

TForm1 = class(TForm)
    ADO: TADOConnection;
    ADOTable1: TADOTable;
    DataSource1: TDataSource;
    ADOTable1Id: TAutoIncField;
    ADOTable1TarihSaat: TDateTimeField;
    ADOTable1Veri: TWideStringField;
    PageControl1: TPageControl;
    TabSheet1: TTabSheet;
    ComboBox1: TComboBox;
    Button1: TButton;
    Memo1: TMemo;
    DBGrid1: TDBGrid;
    Label1: TLabel;
    Label2: TLabel;
    Label3: TLabel;
    procedure ComboBox1Change(Sender: TObject);
    procedure Button1Click(Sender: TObject);
    procedure cmpGPSReceiveData(Sender: TObject; DataPtr: Pointer;
        DataSize: Integer);
    procedure ADOBeforeConnect(Sender: TObject);
    procedure FormCreate(Sender: TObject);
    procedure FormClose(Sender: TObject; var Action: TCloseAction);
private
    { Private declarations }
public
    { Public declarations }
end;

var
    Form1: TForm1;

implementation
{$R *.dfm}
    var buf:string;

```

```

procedure TForm1.ComboBox1Change(Sender: TObject);
begin
    cmpGPS.Disconnect;
end;

procedure TForm1.Button1Click(Sender: TObject); // Serial Port select
combobox procedure
begin
    case ComboBox1.ItemIndex of
        0 : cmpGPS.ComPort := pnCOM1; // Serial Port 1select
        1 : cmpGPS.ComPort := pnCOM2; // Serial Port 2 select
        2 : cmpGPS.ComPort := pnCOM3; // Serial Port 3 select
        3 : cmpGPS.ComPort := pnCOM4; // Serial Port 4 select
    end;
    cmpGPS.Connect;
end;

procedure TForm1.cmpGPSReceiveData(Sender: TObject; DataPtr: Pointer;
    DataSize: Integer);
var p:pchar;
    i,j:integer; //variable definition
    s:string; //variable definition
begin
    p := DataPtr;
    while DataSize > 0 do
    begin
        buf := buf + p^;
        i := pos('$',buf);
        j := pos(#13,buf);
        if (i > 0) and (j>0) then
        begin
            delete(buf,1,i-1);
            j := pos(#13,buf);
            s := copy(buf,1,j-1);

```

```

delete(buf,1,j);
memo1.lines.insert(0,s); //memo box input
AdoTable1.Append;
AdoTable1TarihSaat.AsDateTime := NOW; //insert table1 tarih saat now
AdoTable1Veri.AsString := s; // record type string
AdoTable1.Post;
end;
inc(p);
dec(datasize);
end;
end;
procedure TForm1.ADOBeforeConnect(Sender: TObject);
var s:string; //String Variable definition
begin
s := ExtractFilePath(ParamStr(0));
Ado.ConnectionString :=
'Provider=Microsoft.ACE.OLEDB.12.0;DataSource='+s+'GPS_DATA.mdb;Persi
st Security Info=False'; //mdb database path and ado connection string
end;

procedure TForm1.FormCreate(Sender: TObject);
begin
ADOTable1.Open;
end;
procedure TForm1.FormClose(Sender: TObject; var Action: TCloseAction);
begin
ADOTable1.Close;
ADO.Close;
end;
initialization
buf := "";
end.

```

4.5.3 Test hardware

The test hardware is composed of three main components:

- U-Blox Leon G-100/G200 GSM/GPRS module,
- U-Blox Neo 6M GPS module,
- DAM 1575A4 active antenna.

The hardware is shown on a printed circuit board “PCB” in Figures 21 (front view) and 22 (back view).

LEON G100 quad-band GSM/GPRS data and voice module system in standard hardware has no function during the test operations because it is used for the purpose of transmission to the control center via GPRS.

U-Blox Neo 6M GPS module (Figure 21-22) and DAM 1575A4 active antenna (Figure 24) are the actual test hardware components. Test operation was performed after connecting the GPS PCB with a serial-Universal Serial Bus (USB) converter to a standard laptop computer.

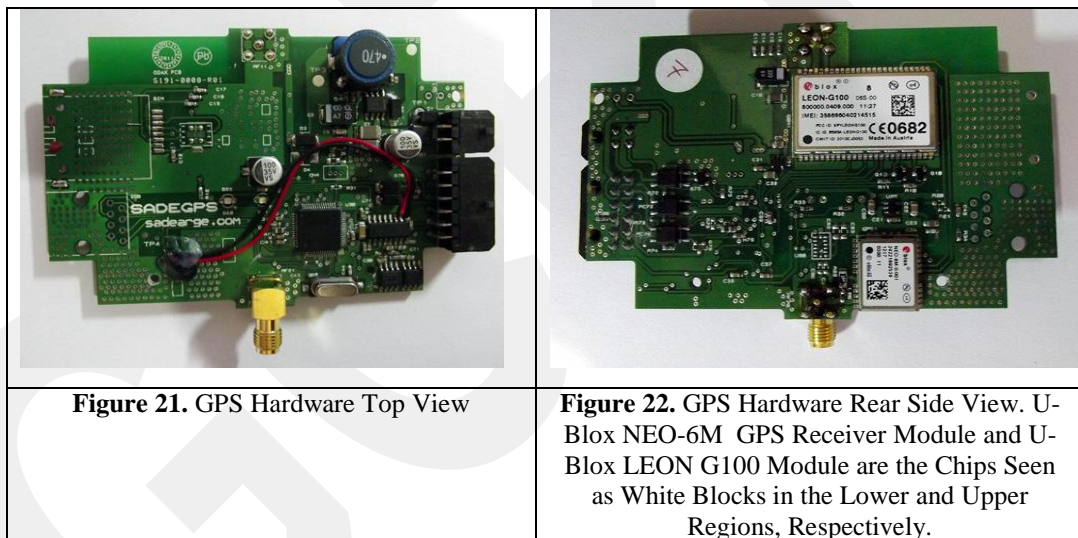

Figure 23 shows the NEO-6M GPS Module Block Diagram. The GPS data is taken from the UART interface.

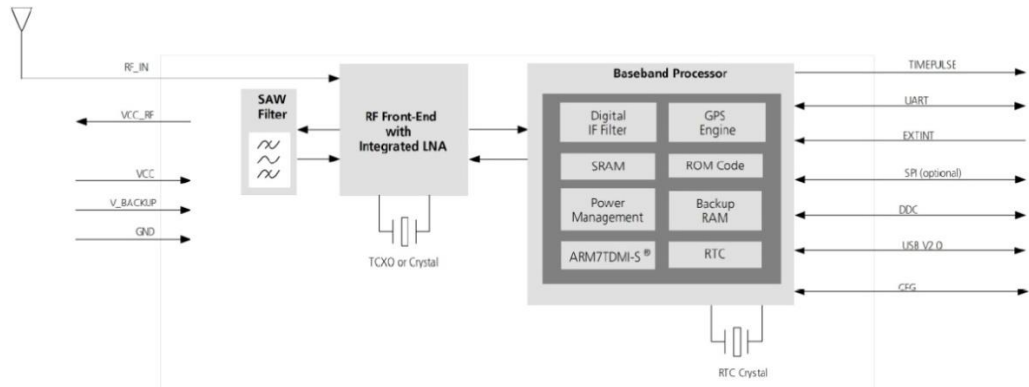

Figure 23. U-Blox NEO-6M Block Diagram [6]



Figure 24. DAM 1575A4 Type Antenna

Please refer to Appendix 7.1 for the detailed information for the antenna. Figure 25 shows test setup with all components.



Figure 25. Test Setup

4.5.4 Comparing the GPS Modules

In the project we have to select the most proper GPS module from among the available products. We used the following criteria:

- The software should be easily developed to support the NMEA in processing the sentences,
- The system should be easily installed in any part of the vehicle and for it to receive healthy signals, using a high gain external antenna type,
- The system should have an affordable price and should have advantageous market conditions such as enough number of products should be available in stock from the vendor,
- The system should be compliant with GPRS module, which will also be on the same PCB, it would be better if they are the products of the same brand for maximum compliance,
- The system should occupy the smallest space in the vehicle.

The comparison according to these criteria is made from the available alternative products and is shown in Table 7.

Table 7. GPS Module Comparison

Module	Size	Price	Antenna Type
MAESTRO WIRELESS SOLUTIONS - A2035H - GPS MODULE [7].	16.5 x 30.5x5 mm	19,34€	On board/Internal
MAESTRO WIRELESS SOLUTIONS - A2200-A GPS MODULE [8].	14 x 10.2x 2,6 mm	13,16€	External
U BLOX NEO-6M GPS MODULE [9].	16x12x2,4 mm	12,20€	External
RF SOLUTIONS - GPS-330R MODULE [10].	34x34x8 mm	46,40€	On board/Internal
MAESTRO WIRELESS SOLUTIONS - A2235H MODULE [11].	17,8x16,5x7,1 mm	15,99€	On board/Internal

We selected the NEO-6M GPS that best meet these criteria.

4.6 Test Process

The test operation described above was performed and the hardware described above were built on a PCB. The test scenario was generated such that the vehicle moved in the specified test route which was predetermined by marking Google Earth software, as shown in Figure 26.

After installing the hardware and initialization, the vehicle started moving in the test route recording the data by running the test software and then recording process terminated when the route was completely driven.

The data acquired was converted to Google Earth format and entered in Google Earth software, as explained in section 4.4.

There are 5-11 meters of differences between real test route and obtained points. These errors are accepted within the tolerance because they are caused by the nature of GPS system and are temporary.



Figure 26. The Test Route

This shows that the GPS records were accurate within the tolerance and the vehicle track was successfully measured and recorded.

4.7 Format Conversion

Here, we give an example of converting the data from the GPS module into to the Google Map format. We measured the data from the GPS module while we were in the garden in Çankaya University's Balgat Campus as

\$GPRMC,141701.00,A,3954.09367,N,03247.77862,E,0.383,,140613,,D*70.

Then we can extract the coordinate data from this as 3954.09370 North, and 03247.77841 East.

Then the procedure of conversion is:

1-Ignore the first two digits in the latitude and 3 digits in the longitude data (that is, from the North and East values, respectively), and take the remaining digits by ignoring the comma. So we have 5409370, and 4777841, respectively,

2- Multiply these numbers with 5/3 to obtain 9015616, and 7963068, respectively, then take them as 0.9015616, and 0.7963068,

3-Add these such that

39.0000000	32.0000000
0.9015616	0.7963068
+-----	+-----
39, 9015616 N	32, 7963068 E

[12].

We indicate the location of this coordinate on Google Earth Map of Çankaya University's Balgat Campus on Figure 27. We used the same conversion in our test of the GPS module in our measurements on the test route.

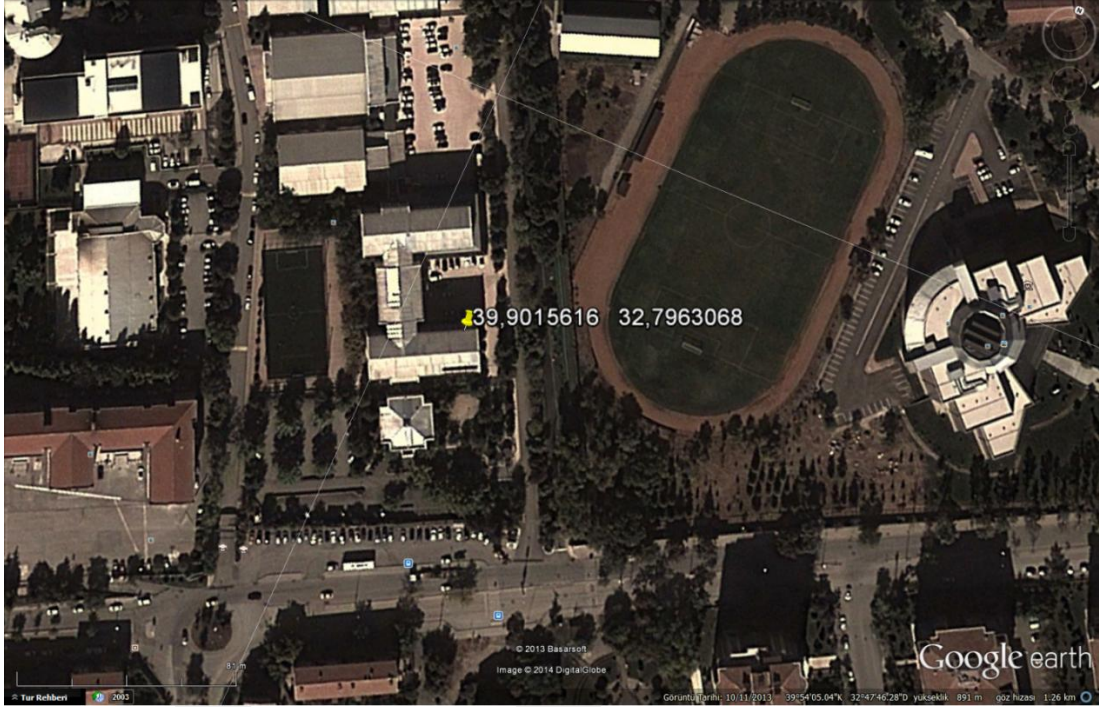

Figure 27. Data Conversion Sample

4.8 Static Test and the Distribution of Measured Data

A test point, of which the coordinates are known well was needed in order to find average error of the coordinate measuring with NEO 6M module at a stationary point. As a result of our request from Ankara City Hall, we were given the coordinates of the landmark point (N39.9777243, E32.7607320) in Ankara, Macunkoy region which was instituted for the land registry and cadastre. We indicated the Google Earth image of the point in Figure 28.



Figure 28. Landmark and Maximum Error Point

The point instituted as landmark point is a concrete structure that its center marked as shown in Figure 29. The stone is called the landmark stone.



Figure 29. Sample Landmark Stone [13]

These points are selected in high places that dominating the environment in order to be able to obtain high performance from GPS and optical devices used in zoning and cadastral measurements. Stationary position measurement process for 100 seconds (about 1.5 minute) has been performed by placing an antenna to the center of this point. We obtained scattered positions around the center as in Figure 30. Collected data has been marked as the point on the coordinate plane in Autocad software of Autodesk Firm after undergoing the coordinate conversion process (Figure 31). The measured values are shown with the conditions we were subject to during measurement in Table 8.

The amount of deviation measured from the center of the landmark point and the parameters during the test can be seen in detail in Appendix 7.2.

Relatively small HDOP parameter values in the GPGGA sentence content show that the distribution of the GPS satellites during measurement is very good [5].

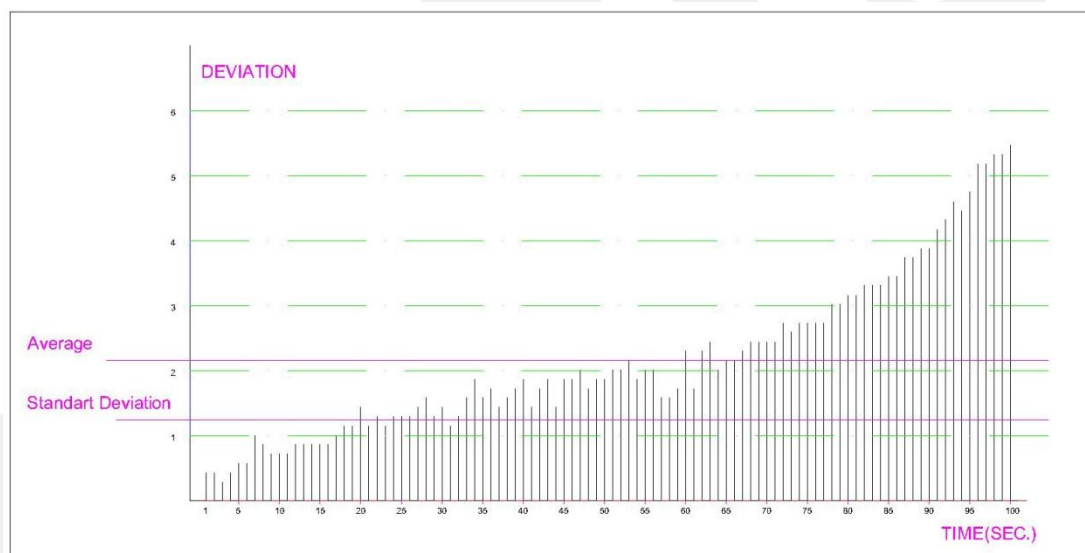

Figure 30. Distribution of Measured Distances from the Center of the Landmark Point in Time

Table 8. Landmark Measurement Test Results

Number of satellites being tracked:	9	HDOP:	1,01
Deviation average:	2,16 m	Maximum error:	5,5 m
Standard deviation:	1,24 m	Number of measurements:	100

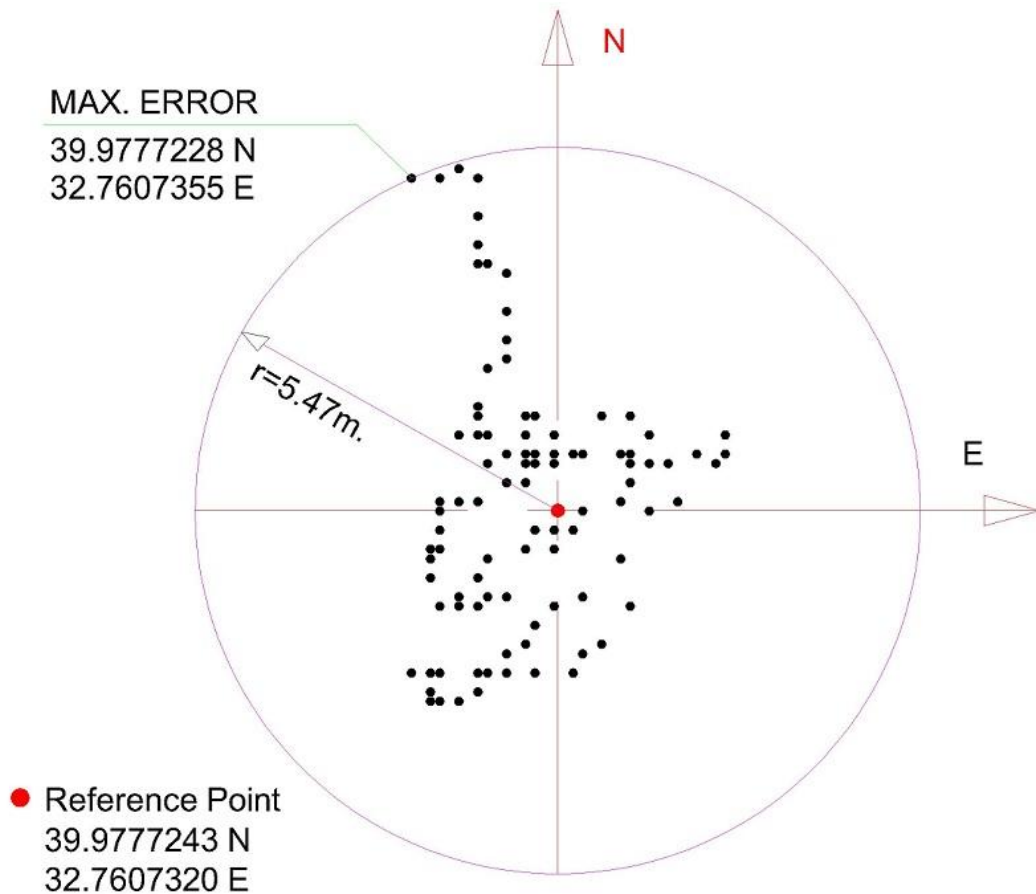

Figure 31. Measured Positions in the Landmark Point

Accuracy of the observation can be evaluated using two parameters in the GPGGA sentence, which is produced by the GPS receiver. These are the number of satellites being tracked and Horizontal Dilution of Precision (HDOP) parameter. As the number of observed satellites increases and HDOP parameter gets smaller the accuracy of the observation increases. The data collected in this process can be seen in detail with all the sentences in Appendix 7.4.

4.9 The Dynamic Test, Measurements on the Test Route

After having made the static measurements and tested the GPS system against the coordinate of a Landmark Point we decided to test the system's dynamic performance. The rationale was that the system may perform properly when the vehicle is not moving but may not perform as required when it is moving. As explained previously, we drove the vehicle with a constant speed on a Test Route while taking measurements by the GPS system regularly in every second. During the test operation, the GPS system measured the position and provided data at a rate of

1Hz. The following test data was obtained from 1.1 km long Test Route at 30 km/h average speed. Test duration is approximately 3.5 minutes. In this case approximately 210 coordinate data was obtained. A complete list of obtained data that are not converted can be found in Appendix 7.3. A subset of the data is given in Table 8.

We did not show all the data values on Figure 32 because otherwise the figure would be very crowded. Instead, we picked up one data point in each 5 data point set, that is, we used the data taken every 5 seconds uniformly and we indicated them on Figure 32. The data displayed in Figure 32 is given in Table 9 as well.

Table 9. A Subset of the Test Route Data List (Converted)

Received Data		
Id	North	East
57	39.9601631	032.7094650
62	39.9602578	032.7092366
67	39.9603276	032.7089720
72	39.9604070	032.7087508
77	39.9605900	032.7088041
82	39.9608210	032.7089751
87	39.9610608	032.7091563
92	39.9612186	032.7092798
97	39.9612216	032.7094746
102	39.9610680	032.7098088
107	39.9608968	032.7102491
112	39.9607354	032.7107528
117	39.9605755	032.7113430
122	39.9604220	032.7119870
127	39.9602681	032.7126391
132	39.9601261	032.7132350
137	39.9600111	032.7137046
142	39.9597948	032.7138511
147	39.9595031	032.7136568
152	39.9591740	032.7134476
157	39.9588530	032.7132375
162	39.9587158	032.7130195
167	39.9588438	032.7126740
172	39.9590098	032.7122911
177	39.9592236	032.7119568
182	39.9594333	032.7115858
187	39.9596030	032.7111318
192	39.9597581	032.7106495
197	39.9599143	032.7101860
202	39.9600375	032.7097590



Figure 32. GPS Test Route Results (Google Earth)

4.10 Test Route Examination

The route (the reference Route) to be followed for the test was marked on the digital map used for zoning studies obtained from the City Hall. The measured coordinate data was placed on this digital map as points while the test vehicle was in motion. Then the measured route from the GPS data was obtained by connecting these points with a straight line (Figure 34). The Autocad file reference to Figure 34 can be seen in Appendix 7.5.

In order to determine the deviation between the obtained reference route and the GPS route, perpendicular lines were drawn from each measured point on the GPS route to the reference route and the length of these lines were calculated. An example of drawing the perpendicular line from a GPS measured position to the Reference Route is shown in Figure 33.

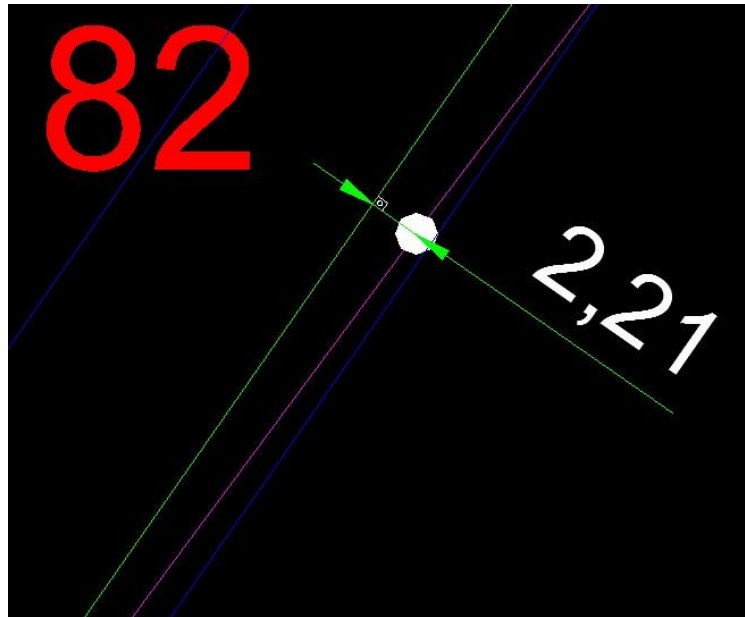

Figure 33. Sample Perpendicular Measurement

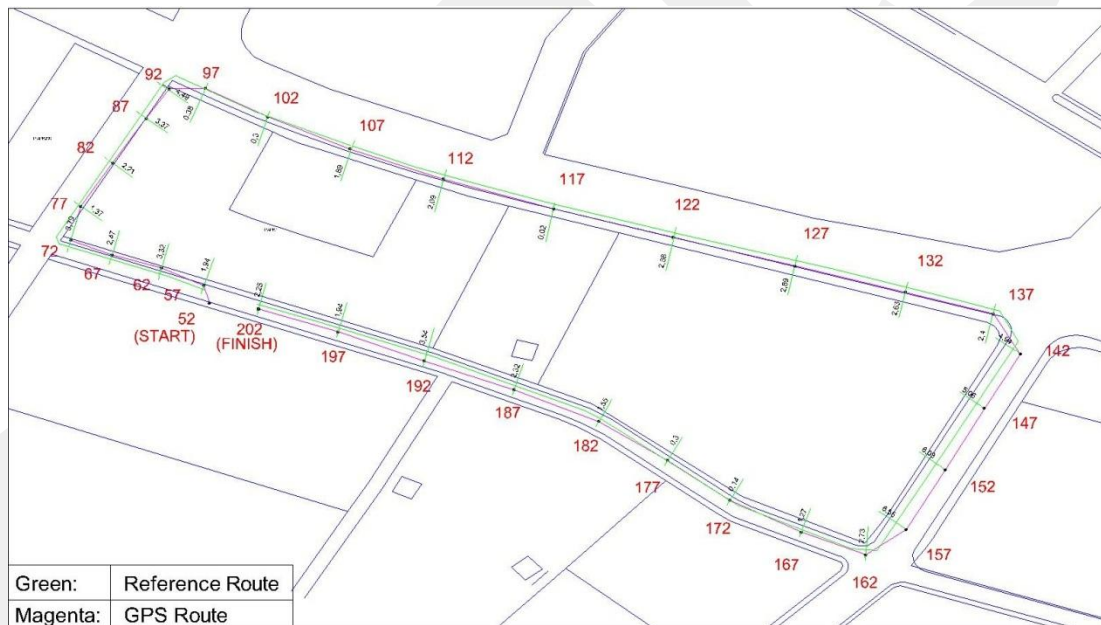

Figure 34. GPS Measurements Points on Digital Map, Which is Provided by the City Hall (Autocad)

This length value of the line shows how much the measured position deviates from the reference point. The lengths of the lines drawn from the measured positions to the Reference Route obtained along the route are given in Table 10 together with the parameters.

Table 10. The Test Route Parameters

Number of Point	Deviation	HDOP(From GPGGA Sentence)	Number of Satellites Being Tracked (From GPGGA Sentence)
57	1,94	1.17	07
62	3,32	1.17	07
67	2,47	1.17	07
72	3,79	1.17	07
77	1,37	1.17	07
82	2,21	1.17	07
87	3,37	1.17	07
92	4,49	1.17	07
97	0,38	1.17	07
102	0,30	1.17	07
107	1,89	1.17	07
112	2,09	1.17	07
117	0,02	1.17	07
122	2,58	1.17	07
127	2,89	1.17	07
132	2,63	1.17	07
137	2,40	1.17	07
142	4,94	1.17	07
147	5,06	1.17	07
152	6,03	1.17	07
157	6,55	1.17	07
162	2,73	1.17	07
167	1,27	1.17	07
172	0,14	1.17	07
177	0,30	1.17	07
182	1,55	1.17	07
187	2,32	1.07	07
192	3,54	1.17	07
197	1,94	1.30	06
202	2,25	1.17	07
Test Parameters			
HDOP:	1.17	Number of satellites being tracked	07
Maximum error:	6,55m	Distribution average:	2,55m
Standard deviation:	1,66	Number of points:	30

To assess test results better in comparing the results of static test measurements with the dynamic test measurements we need to compare the parameters obtained in both

tests. The comparison between the static and the dynamic tests parameters are made in Table 11. We observed from this table that as the number of satellites tracked during the measurement is higher than the HDOP value gets smaller and the error between the correct position and the GPS measured position gets smaller. This means that our accuracy of measurement was better when we were making static test and then that when we were making the dynamic test.

Table 11. Comparison of Parameters Between the Static and Dynamic Tests

Static Test		Dynamic Test	
HDOP:	1.01	HDOP:	1.17
Number of satellites being tracked	09	Number of satellites being tracked	07
Maximum error:	5,5m	Maximum error:	6,55m
Distribution average:	2,16m	Distribution average:	2,55m
Standard deviation:	1,24m	Standard deviation:	1,66
Number of points:	100	Number of points:	30

In general, there are errors in all of the measurements on the test route even if within the SPS. The reasons of these errors are: [14]

- ✓ Atmospheric effects,
 - Ionospheric effects,
 - Tropospheric effects,
- ✓ Multipath effect,
- ✓ Ephemeris and Clock Errors.

We can conclude that the GPS system position measurement accuracy test was performed successfully and the errors made in both static and dynamic conditions were much better than the accuracies required for the GPS Module in the Freelog Logistic System.

It has been observed that the test was successful and the results were within the SPS error limits. Therefore, we demonstrated and verified in the tests that the GPS Module was selected correctly, and it can be used safely in the Freelog Logistic System.

CHAPTER 5

CONCLUSION AND FUTURE WORK

In this study we chose, tested and verified a GPS Module to be used in measuring the positions of the vehicles that are involved in the Freelog Logistic System. The Freelog Logistic System aims to eliminate the disadvantages of conventional transportation as a transportation system on a national scale. Designing of such a logistic system involves software engineering, logistic management, business, and electronic and communication engineering.

While the Freelog Logistic System aimed at efficient use of economical resources, on the other hand it brings benefits such as safety, traceability, prevention of informal economy and creating professional organization.

The main topic of this thesis is the selection of positioning sub-system with GPS, that is a GPS Module, and after testing it properly verifying that it provides the required position accuracy for the vehicles. We first chose the GPS Module from the available commercial products, and then we developed the test hardware and software. We generated static and dynamic test scenarios, executed the tests and made measurements. We reduced the measured data from the GPS Module selected and converted them into the required position data types. We then compared these test results with the reference validated data provided by the City Hall. We showed that the position measurement accuracy obtained from the GPS Module was better than the accuracy value required by the Freelog Logistic System.

The testing environment was established by procuring the vehicle tracking hardware to be used in each carrier vehicle including the GPS Module and the software that capture the data from the GPS Module was developed. Study on the format conversion was done to extract the correct geographical coordinates from the data provided by the GPS Module and the required process was developed. The software developed was designed to record the data coming from the GPS Module in real time into a MDB database file in a PC computer.

In static test, we made measurements of positions by the GPS Module at a fixed reference position created by the City Hall for cadastral work. We compared the measured data against the coordinate of this reference landmark point. We recorded the satellite parameters (HDOP and the number of satellites tracked during the measurements) provided by the GPS System.

In dynamic test we chose a proper test route of a race track shape such that we could drive a vehicle with a constant speed on it. We succeeded to get the correct coordinates of the route selected from the City Hall on a digital map. This constituted our reference route for the dynamic test. We then made the test by making position measurements with the GPS Module at each second while the vehicle was on the move with a constant speed. We compared then the measured data, the GPS route, with the reference route and calculated the deviations from the reference route. We recorded the parameters of HDOP and number of satellites tracked during the test like we had done for the static test.

When we compared the results between the static and dynamic tests together with the parameter values recorded for both cases we saw that the deviations between the measured positions and the reference positions depend on the unpredictable satellite conditions (HDOP) and their numbers. The deviations between the measured and reference positions were seen to be within the error limits of the GPS System and the GPS Module was running correctly.

The position data measured in different time even in the static test differed from one another. This was normal and an expected behavior of the GPS System. The reason is that the number and positions of the GPS satellites tracked are changing continuously in time and the signal from the GPS System is also affected by the atmospheric and other environmental effects. However, the results we obtained were shown to be within the SPS limits of the GPS System.

The negative effects of atmospheric conditions and the environment such as closed or semi-closed environments (tunnels and wooded areas for instance) are the most serious problems for a GPS positioning system. In order to reduce these effects we need more effective satellite signals and more satellites tracked. The problem can be

minimized by using more effective antennas and with more effective error correction algorithms used in measurement software.

In the future a better antenna can be used and better correction algorithms can be developed to reduce the position errors obtained from a GPS Module.

GCPRIS

REFERENCES

- [1] Image, Retrieved from <http://www.freelog.com.tr>, on 25 June 2013
- [2] Retrieved from <http://www.gpsinformation.org/dale/nmea.htm>, 25 February 2014
- [3] **XU, G.** (2007), GPS Theory, Algorithms and Applications Second Edition, Springer.
- [4] **KAPLAN, E.D., HEGARTY, J.C.** (2006), Understanding GPS Principles and Applications Second Edition, Artech House.
- [5] Retrieved from [http://en.wikipedia.org/wiki/Dilution_of_precision_\(GPS\)](http://en.wikipedia.org/wiki/Dilution_of_precision_(GPS)), 10 March 2014
- [6] Retrieved from http://www.u-blox.com/images/downloads/Product_Docs/NEO-6_DataSheet_%28GPS.G6-HW-09005%29.pdf, 13 December 2013
- [7] Retrieved from <http://www.farnell.com/datasheets/1794015.pdf>, 25 March 2014
- [8] Retrieved from <http://www.farnell.com/datasheets/1681427.pdf>, 25 March 2014
- [9] Retrieved from https://www.u-blox.com/images/downloads/Product_Docs/NEO-6_DataSheet_%28GPS.G6HW-09005%29.pdf, 25 March 2014
- [10] Retrieved from <http://www.rfsolutions.co.uk/acatalog/DS-330R-3.pdf>, 25 March 2014
- [11] Retrieved from <http://www.farnell.com/datasheets/1681425.pdf>, 25 March 2014
- [12] Retrieved from http://home.online.no/~sigurdhu/Deg_formats.htm, 4 March 2014
- [13] Image, Retrieved from <http://www.geoks.com.tr/proje-hizmetlerimiz.aspx>, 10 March 2014
- [14] Retrieved from http://en.wikipedia.org/wiki/Error_analysis_for_the_Global_Positioning_System, 27 March 2014

7. APPENDIX

7.1 DAM1575A4 GPS Active Antenna

Part Number: DAM 1575A2A4, DAM1575C2A4

Antenna Specification

	DAS1575R (25 X 25 X 4)	DAS1575R18 (18 X 18 X 4)
Center Frequency	1575.42 MHz \pm 3 MHz	1575.42 MHz \pm 3 MHz
V.S.W.R	1.5 : 1	1.5 : 1
Band Width	\pm 5 MHz	\pm 3 MHz
Attenuation	$f_0 \pm 100$ MHz > 30 dB	$f_0 \pm 100$ MHz > 30 dB
Impedence	50 ohm	50 ohm
Peak Gain	> 3dBic Based on 7 X 7cm ground plane	> 2dBic
Gain Coverage	> -4dBic at -90°C < 0 < +90°C (over 75% Volume)	> -2dBic at -90°C < 0 < +90°C (over 75% Volume)
Polarization	RHCP	RHCP

LNA Specification

	DAM1575A2A4	DAM1575C2A4
LNA Gain (without cable)	27 dB typical	27 dB typical
Noise Figure	1.5 dB	1.5 dB
V.S.W.R	< 2.0	< 2.0
DC Voltage	3.0V \pm 0.3V	3.0V \pm 0.3V
DC Current	15mA Max	15mA Max

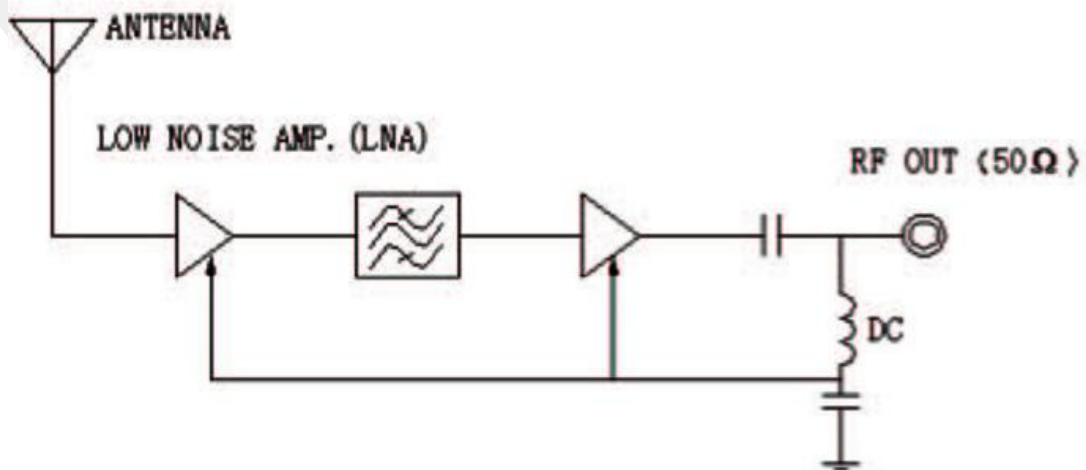

Mechanical Specification

	DAM1575A2A4	DAM1575C2A4
Weight	< 100 g	< 90 g
Size	50 X 39 X 16 mm	50 X 39 X 16 mm
Cable	SYV-50-2, 5 meter long or other RG174, 5 meter long or other	
Connector	MCX	MCX
Mounting	Magnetic base	Magnetic base
Housing	Black	Black

Environmental Specification

Work Temperature	-40°C ~ +85°C	-40°C ~ +85°C
Storage Temperature	-40°C ~ +100°C	-40°C ~ +100°C
Vibration	Sine sweep 1g(0-p) 10 ~ 50 ~ 10 Hz each axis	
Humidity	95% ~ 100% RH	
Weatherproof	100% waterproof	
MTBF = 1X10⁶/pc.hr	40°C ± 5°C, DC = 5V ± 0.5V Qty = 2000 pcs, lasting 480 hours	

WORLD BOND PIEZO-ELECTRIC CORP.

215 – 3751 Jacombs Road, Richmond, B.C., Canada V6V 2R4

Tel : (604) 821-1168 Fax: (604) 821-1623

E-Mail: sales@worldbond.com Website: www.worldbond.com

7.2 Landmark Test Parameters

Number of Point	# Satellite	HDOP	Deviation
1	09	1,01	0,43
2	09	1,01	0,43
3	09	1,01	0,28
4	09	1,01	0,43
5	09	1,01	1,15
6	09	1,01	0,57
7	09	1,01	0,86
8	09	1,01	0,86
9	09	1,01	0,72
10	09	1,01	0,86
11	09	1,01	0,72
12	09	1,01	1,72
13	09	1,01	0,86
14	09	1,01	1
15	09	1,01	0,72
16	09	1,01	0,86

Appendix 7.2 Continued

17	09	1,01	1,44
18	09	1,01	1,15
19	09	1,01	1,87
20	09	1,01	1,44
21	09	1,01	1,15
22	09	1,01	1,29
23	09	1,01	1,87
24	09	1,01	1,29
25	09	1,01	1,29
26	09	1,01	1,29
27	09	1,01	1,44
28	09	1,01	1,58
29	09	1,01	0,86
30	09	1,01	1,44
31	09	1,01	0,57
32	09	1,01	1,29
33	09	1,01	1,58
34	09	1,01	1,15
35	09	1,01	1,58
36	09	1,01	1,29
37	09	1,01	1,44
38	09	1,01	1,58
39	09	1,01	1,72
40	09	1,01	1,87
41	09	1,01	1,44
42	09	1,01	1,72
43	09	1,01	1,87
44	09	1,01	1
45	09	1,01	1,87
46	09	1,01	1,15
47	09	1,01	2,01
48	09	1,01	1,87
49	09	1,01	1,72
50	09	1,01	1,87
51	09	1,01	2,01
52	09	1,01	2,01
53	09	1,01	2,16
54	09	1,01	1,87
55	09	1,01	2,01
56	09	1,01	2,01
57	09	1,01	1,58
58	09	1,01	1,87
59	09	1,01	1,72
60	09	1,01	2,3
61	09	1,01	1,72
62	09	1,01	2,3
63	09	1,01	2,44

Appendix 7.2 Continued

64	09	1,01	2,01
65	09	1,01	2,16
66	09	1,01	2,16
67	09	1,01	2,3
68	09	1,01	2,44
69	09	1,01	2,44
70	09	1,01	2,44
71	09	1,01	2,44
72	09	1,01	2,73
73	09	1,01	2,59
74	09	1,01	2,73
75	09	1,01	2,73
76	09	1,01	2,73
77	09	1,01	2,73
78	09	1,01	3,02
79	09	1,01	3,02
80	09	1,01	3,16
81	09	1,01	3,16
82	09	1,01	3,31
83	09	1,01	3,31
84	09	1,01	3,31
85	09	1,01	3,45
86	09	1,01	3,45
87	09	1,01	3,74
88	09	1,01	3,74
89	09	1,01	3,88
90	09	1,01	3,88
91	09	1,01	4,17
92	09	1,01	4,32
93	09	1,01	4,6
94	09	1,01	4,46
95	09	1,01	4,75
96	09	1,01	5,18
97	09	1,01	5,18
98	09	1,01	5,32
99	09	1,01	5,32
100	09	1,01	5,47

7.3. Test Route GPS Data List (Excel file)

Test route measurement data shown external excel file

7.4 Stationary Point Landmark Measurement Raw Data List (Excel file)

Landmark Measurement data shown external excel file

7.5 Autocad drawing file (Figure 34)

Autocad data shown external dwg file

GCCRIS

CURRICULUM VITAE

PERSONAL INFORMATION

Surname, Name : ŞEKER, Reşat

Nationality : Turkish (TC)

Date and Place of Birth : 10.05.1979, ANKARA

Marital Status : Single

Phone : +90 505 340 96 24

Email : golge1@hotmail.com

EDUCATION

Degree	Institution	Year of Graduation
High School	ANKARA UNIVERSITY - Industrial Electronic	2002
BS	Anadolu University - Business Administration	2009

WORK EXPERIENCE

Year	Place	Enrollment
2003-2008	TEK NOKTA BİLİŞİM HİZMETLERİ	Designer- Programmer
2008-2010	ÖZBİLEK TEKNİK CİHAZLAR LTD.	Service Manager
2010-Present	ELTEMTEK A.Ş.	Project Designer

FOREIGN LANGUAGES

English – Good.

HOBBIES

Dance, tracking, outdoor sports,movies.