

**MOBILE AD-HOC NETWORKS FOR E-HEALTH CARE DECISION
SUPPORT SYSTEM**

**A THESIS SUBMITTED TO
THE GRADUATE SCHOOL OF NATURAL AND APPLIED
SCIENCES OF
ÇANKAYA UNIVERSITY**

**BY
MUSTAFA TAREQ AL-QAISI**

**IN PARTIAL FULFILLMENT OF THE REQUIREMENTS FOR THE
DEGREE OF
MASTER OF SCIENCE
IN
THE DEPARTMENT OF
COMPUTER ENGINEERING**

AUGUST 2014

Title of the Thesis : **Mobile Ad-hoc Networks for E-health Care Decision Support System**

Submitted by **Mustafa Tareq AL-QAISI**

Approval of the Graduate School of Natural and Applied Sciences, Çankaya University.



Prof. Dr. Taner ALTUNOK
Director

I certify that this thesis satisfies all the requirements as a thesis for the degree of Master of Science.



Assist. Prof. Dr. Murat SARAN
Head of Department

This is to certify that we have read this thesis and that in our opinion; it is fully adequate, in scope and quality, as a thesis for the degree of Master of Science.



Assist. Prof. Dr. Yuriy ALYEKSYEYENKOV
Supervisor

Examination Date : 08.08. 2014

Examining Committee Members

Assist .Prof. Dr. Yuriy ALYEKSYEYENKOV (Çankaya Univ.)
Assoc. Prof. Dr. Fahd JARAD (THK Univ.)
Assist. Prof. Dr. Abdül Kadir GÖRÜR (Çankaya Univ.)



STATEMENT OF NON-PLAGIARISM PAGE

I hereby declare that all information in this document has been obtained and presented in accordance with academic rules and ethical conduct. I also declare that, as required by these rules and conduct, I have fully cited and referenced all material and results that are not original to this work.

Name, Last Name : Mustafa Tareq AL-QAISI

Signature :



Date

: 08.08. 2014

ABSTRACT

MOBILE AD-HOC NETWORKS FOR E-HEALTH CARE DECISION SUPPORT SYSTEM

AL-QAISI, Mustafa

M.Sc. Department of Computer Engineering

Supervisor: Assist. Prof. Dr. Yuriy ALYEKSYEYENKOV

Co-Supervisor: Assist. Prof. Dr. Mohammed AL-SALAM

August 2014, 65 Pages

E-Healthcare systems are considered one of the most important issues all around the world; it solves the problems that the system staffs were facing before putting such a smart system in charge. E-Healthcare systems allow an easy way for connecting people with each other directly and whenever is possible such as connecting the patients with their doctors, in order to check patient situation. Hereby, the studying and analyzing to the Intelligent Decision Support (IDS) for E-Healthcare system was done. The thesis consists of two parts, (First) a specific network is designed to support the system, Mobile Ad-hoc Network (MANET) has been chosen as the network because it allows an easier way for data transmitting, reliability and scalability. The most important issue to design MANET is the routing protocol. Generally, routing protocols are classified into three types: proactive, reactive and hybrid. The thesis concentrates on studying Destination Sequence Distance Vector

DSDV (proactive) and Ad-Hoc On-Demand Distance Vector AODV (reactive) routing protocols.

A performance comparison between these two protocols is done in this work to select the best routing protocol using NS2 Simulator based on packet delivery ratio (PDR), drop packet, throughput and End to End delay. And the comparison results gave that AODV performance is better than DSDV then it is the suitable routing protocol of the network for the proposed system. (Second) the entire components that are needed to design a typical E-healthcare system are studied and designed. These components are represented by patient mobile interface, database, medical server and healthcare provider interface. C# and SQL server management R2 2008 are used for programming these issues. Moreover, the system is supported by studying and choosing the best rule to make the decision maker works efficiently. Finally, a smart website is designed in this thesis using ASP.net program to govern and control system information.

Keywords: AODV, DSDV, E-HealthCare Systems, Intelligent Decision Support System, Mobile Ad-hoc Networks, NS2 Simulator.

ÖZ

E-SAĞLIK KARAR DESTEK SİSTEMİ İÇİN MOBİL AD-HOC AĞLARI

AL-QAISI, Mustafa

Yüksek Lisans, Bilgisayar Mühendisliği Anabilim Dalı

Tez Yöneticisi: Yrd. Doç. Dr. Yuriy ALYEKSYEYENKOV

Yardımcı Tez Yöneticisi: Yrd. Doç. Dr. Mohammed AL-SALAM

Ağustos 2014, 65 Sayfa

E-Sağlık hizmet sistemleri dünya çapında en çok incelenen konulardan birisidir. Bu sistem, sistem çalışanlarının akıllı bir sistem olmadan önceki karşılaştığı sorunları çözmektedir. E-Sağlık hizmet sistemleri istendiği zaman hastanın durumunun kontrol edilmesi için hasta ile doktor arasındaki iletişimi kolay bir yol ile sağlamaktadır. Bu sebeple, E-Sağlık hizmet sistemi için bir Akıllı Karar Destek Sistemi (Intelligent Decision Support System, IDSS) incelendi ve çalışıldı. Bu tez iki çalışmadan oluşmaktadır. İlk olarak destek sistemi için özel bir ağ tasarlandı. Hareketli Eşe-Eş Ağ (Mobile Ad-hoc Network, MANET), veri gönderme, güvenilirlik ve ölçeklenebilirlik hususlarında kolaylık sağladığı için özel ağ olarak seçildi. Yönlendirme protokolü, MANET tasarımındaki en önemli konudur. Genellikle yönlendirme protokolleri üç tipe ayrılmaktadır. Bunlar, proaktif, reaktif ve melez tipleridir. Bu tezde proaktif olarak Hedef-Sıralı Uzaklık Vektör (Destination Sequence Distance Vector, DSDV) ve reaktif olarak da Eşe-Eş İsteğe Bağlı Uzaklık Vektör (Ad-Hoc On-Demand Distance Vector, AODV) yönlendirme protokolleri

üzerinde yoğunlaşıldı. Bu iki protokol arasından en iyiyi seçmek için NS2 simülatörü kullanılarak, paket gönderi oranına, drop packet, iş zaman oranına ve uç- uca gecikme miktarına göre performans karşılaştırması yapıldı. Bunun sonucunda AODV' nin performansının DSDV' nin performansına göre daha iyi olduğuna ve AODV' nin önerilen sistem için uygun yönlendirme protokolü olduğuna karar verildi. İkinci çalışmada ise tipik bir E-Sağlık hizmet sistemi oluşturmak için gerekli tüm bileşenler çalışıldı ve tasarlandı. Bu bileşenler hasta mobil ara yüzü, veritabanı, medikal sunucu ve sağlık hizmeti sağlayıcı ara yüzü olarak belirlendi. Bu bileşenleri programlamada C# ve SQL sunucu yönetimi R2 2008 kullanıldı. Ek olarak sistem, karar vericinin verimli çalışması için çalışılıp seçilen en iyi kural ile desteklendi. Son olarak sistem bilgilerini yönetmek ve kontrol etmek için ASP.net programı kullanılarak akıllı bir internet sitesi tasarlandı.

Anahtar Kelimeler: AODV, DSDV, E-Sağlık Hizmet Sistemleri, Akıllı Karar Destek Sistemi, Hareketli Eşe-Eş Ağlar, NS2 Simülatörü.

ACKNOWLEDGMENTS

I would like to express my sincere gratitude to my thesis advisor Assist. Prof. Dr. Yuriy ALYEKSYEYENKOV and my co-advisor Assist. Prof. Dr. Mohammed AL-SALAM, who they have encouraged and guided me throughout this thesis patiently.

My deepest gratitude to my father and mother for their encouragement and prayers that make me successful and hopeful in the life.

I also would like to express my sincere gratitude to my lovely sister and brother as well as my dearest and lovely aunts Dr.Elham Nafi Al-KAISSI and Dr. Orooba .N. Abdullah, who they supported and encouraged me along my life.

My great thanks to my friends Ahmed Mosa DINAR, Ayad Esho KORIAL, Mohammed Naji AL-KAISSI and all other friends for what have they done for me and for their help along my thesis work.

Finally, I thank Çankaya University precisely Computer Engineering Department for their support and creating the appropriate requirements necessary during my study. In addition, my gratitude and sincere thanks to University of Technology in Iraq for their support and the help they allowed.

TABLE OF CONTENTS

STATEMENT OF NON PLAGIARISM.....	iii
ABSTRACT.....	iv
ÖZ.....	vi
ACKNOWLEDGEMENTS.....	viii
TABLE OF CONTENTS.....	ix
LIST OF FIGURES.....	xi
LIST OF TABLES.....	xiii
LIST OF ABBREVIATIONS.....	xiv

CHAPTERS:

1. INTRODUCTION.....	1
1.1. Background and Motivation.....	1
1.2. E-Healthcare Challenges.....	3
1.3. Literature Survey.....	4
1.4. Thesis Aims.....	7
1.5. Thesis Outline.....	8
2. THEORETICAL CONCEPTS.....	9
2.1. Introduction.....	9
2.2. Decision Support System.....	9
2.2.1. Decision Support System Architecture.....	9
2.2.2. Decision Support System Applications.....	11
2.3. E-Health Care Decision Support System.....	11
2.3.1. Concepts of E-Healthcare System.....	11
2.3.2. Applications of E-Healthcare System.....	12
2.3.3. Components of E-Health Care System.....	13
2.3.3.1. Patient Side.....	15
2.3.3.2. Medical Server Side.....	17
2.3.3.3. Health Care Provider Side.....	20
2.4. Mobile Ad-Hoc Networks.....	20
2.4.1. History of Mobile Ad-Hoc Networks.....	21

2.4.2.	Architecture of Mobile Ad-Hoc Network	22
2.4.3.	Mobile Ad-Hoc Networks Challenges	23
2.4.4.	Mobile Ad-Hoc Network Routing Protocols.....	24
2.4.4.1.	Destination Sequence Distance Vector	25
2.4.4.2.	Ad-hoc On-demand Distance Vector	27
2.4.5.	Mobile Ad-Hoc Networks Application	28
3.	PROPOSED NETWORK	29
3.1.	Introduction	29
3.2.	Simulation Environment.....	29
3.3.	Network Topology Proposed.....	30
3.4.	Network Parameters	33
3.5.	Metrics Calculations.....	34
3.6.	Parameters Computation	35
3.7.	Simulation Result	40
4.	SYSTEM DESIGN	43
4.1.	Introduction	43
4.2.	Proposed System	43
4.3.	System Requirements	44
4.3.1.	Hardware Requirements.....	44
4.3.2.	Software Requirements	44
4.4.	Patient Tier Design	45
4.5.	Medical Server Tier Design.....	47
4.5.1.	Database Design.....	48
4.5.2.	Decision Making Implementation.....	49
4.6.	Healthcare Provider Tier Design	57
4.7.	Web Site Design	58
5.	CONCLUSION AND FUTURE WORK.....	64
5.1.	Conclusion.....	64
5.2.	Future Work.....	65
	REFERNCES	R1
	APPENDICES A.....	A1
	A. CURRICULUM VITAE.....	A1

LIST OF FIGURES

FIGURES

Figure 1	Decision support system	11
Figure 2	E-Healthcare system	14
Figure 3	Components of sensor node	16
Figure 4	WBAN	17
Figure 5	Medical server for E-Healthcare system.....	18
Figure 6	Database for E-Healthcare system	19
Figure 7	Decision maker process	20
Figure 8	Mobile ad-hoc network.....	21
Figure 9	Infrastructure network.....	22
Figure 10	Mobile ad-hoc network transmission range.....	23
Figure 11	MANETs routing protocols.....	25
Figure 12	Creation new route path for node A.....	26
Figure 13	Route request (RREQ) flooding	27
Figure 14	Route reply (RREP) propagation	28
Figure 15	Software architecture for NS2 simulation	30
Figure 16	E-Healthcare network with 40 patients.....	31
Figure 17	E-Healthcare network with 100 patients.....	32
Figure 18	Trace file	36
Figure 19	Throughput TCL code.....	38
Figure 20	PDR, E2Edelay, drop packet TCL code.....	39
Figure 21	Throughput Vs varying number of nodes	40
Figure 22	PDR Vs. varying number of nodes	40
Figure 23	End-To-End delay Vs. varying number of nodes.....	41
Figure 24	Drop packets Vs. varying number of nodes.....	41
Figure 25	Over view of the proposed system.....	44
Figure 26	HOLTER report.....	46

FIGURES

Figure 27	Mobile patient	47
Figure 28	Activity block diagram for the proposed system	50
Figure 29	Heartbeat analysis block diagram	53
Figure 30	Blood pressure analysis block diagram	55
Figure 31	The proposed medical server	56
Figure 32	Alarm types	56
Figure 33	Doctor interface alarms	57
Figure 34	E-Healthcare system website	58
Figure 35	Administrator web page	59
Figure 36	New patient registration webpage	60
Figure 37	Doctor login webpage	61
Figure 38	Quick patient search by ID	61
Figure 39	Patient information and take action by doctor	62
Figure 40	Contact us web page	63

LIST OF TABLES

TABLES

Table 1	Route Path Update	26
Table 2	Network Parameter	33
Table 3	Database Entities	49

LIST OF ABBREVIATIONS

US	United State
EU	European Union
HIS	Health Information System
EHR	Electronic Health Record
HMIS	Health Management Information System
UAE	United Arab Emirates
MANETs	Mobile Ad-Hoc Networks
SMS	Short Message Send
GSM	Global System for Mobile Communication
PDA	Personal Digital Assistant
PC	Personal Computer
GPRS	General Packet Radio Service
PPHS	Patients Personal Home Server
IMS	Intelligent Medical Server
SQL	Structured Query Language
PHP	Personal Home Page
DG&T	Data Gathering and Transmission
M&S	Monitoring and Surveillance
MCS	Management, Control and Storage
AODV	Ad Hoc On-Demand Distance Vector
DSDV	Destination-Sequenced Distance-Vector
PDF	Packet Delivery Fraction
NRL	Normalized Routing Load
PDR	Packet Delivery Ratio
DSR	Dynamic Source Routing
NS2	Network Simulator 2

CBR	Constant Bit Rate
TCP	Transmission Control Protocol
DSS	Decision Support System
ICUS	International Chronic Urticarial Society
WBAN	Wireless Body Area Network
WHO	World Health Organization
ORP	Optoelectronic Retinal Prosthesis
ECG	Electrocardiography
EMG	Electromyography
EEG	Electroencephalography
ADC	Analog to Digital Converter
MS	Medical Server
EDGE	Enhanced Data Rates for GSM Evolution
GPS	Global Positioning System
ALOHA	Arial Locations of Hazardous Atmospheres
CSMA	Carrier Sense Medium Access
DARPA	Defense Advanced Research Project Agency
SURAN	Survivable Adaptive Radio Networks
GSR	Global State Routing
HSR	Hierarchical State Routing
LAR	Location Aided Routing
TORA	Temporally Ordered Routing Algorithm
ZRP	Zone Based Routing Protocol
RREQ	Route Request
RREP	Route Reply
RERR	Route Error
MAC	Media Access Control
TCL	Tool Command Language
OTCL	Object Oriented Extension of Tcl

ASP	Active Server Pages
NC	Normal Case
UA	Upper Abnormal
LA	Lower Abnormal
NS	Normal Systole
ND	Normal Diastole
SUA	Systole Upper Abnormal
SLA	Systole Lower Abnormal
DUA	Diastole Upper Abnormal
DLA	Diastole Lower Abnormal
IMHMS	Intelligent Mobile Health Monitoring System

CHAPTER 1

INTRODUCTION

In this chapter E-healthcare system background has been described. This background firstly describes the history of E-healthcare systems and applied to several developed countries such as (Turkey, Russia and UAE). Also the challenges of E-healthcare systems will be presented. Then, discuss the related works for this thesis. Finally thesis aims and outline will be listed.

1.1. Background and Motivation

In recent years the world went to the electronic direction. Computer applications are used in all fields of life, whether it was in the field of industry, health and all areas of life. Almost all natural phenomena are digitized now. The improvements in computer technologies are increasing rapidly and continuously, covering all fields of the life. Employment of computer technology in the field of health-care is an ancient event but there are still some things of health-care where computer applications can make a difference. Improving the quality of life for chronic disease patients by computer application is one of those. Chronic diseases are a most dangerous type of diseases which can make the life miserable. In most of the cases; the disease changes the life of patient up-side-down. Chronic disease patients have to live with the disease [1].

Health care system is one of the major issues for providing better and easy life for patients whose have any type of chronic disease. Each year millions of people die from chronic diseases, In EU countries, the heart disease is the most common cause of death. From the US National Center for Health Statistics, major chronic diseases such as heart disease, cerebrovascular disease, and diabetes account for 35.6% of death in US in the year 2005. In addition to basic health care deficiencies, major public health threats face all from shortage of health professionals,

insufficient health education, to out of date clinical treatment. Lack of access to accurate and health awareness, therefore the recent researches concentrate on the health care field [2].

E-Healthcare means employing the electronic tools to establish an interaction between patients and doctors for health related uses. In order to enhance the quality and safety conditions of health care, E-Health is the best suitable way could be applied with the use of recent information and communication technology that be used to face all needs of patients, citizens, health care providers, doctors etc. In other way, E-Health stands for electronic health, which refers to healthcare practice supported by electronic processes, Internet communication and related technologies [3].

Health Information System [HIS] is a typical application of E-Health. With the help of HIS, such as Electronic Health Record [EHR] and Health Management Information System [HMIS], healthcare providers can manage the patients files more organized and get health care information more conveniently, so as to provide health care services more efficiently[4]. For optimizing the healthcare sector in all developed and developing countries (E-Health News; E-Health Europe, 2009; ITU, 2008; Drury P; S. Denise, 2003), E-Health activities are becoming common and have the ability to do this. Finally the increase in the incidence of chronic diseases and increasing the proportion of deaths, causes the E-Healthcare studies to be improved, this will give both patients and healthcare providers more flexibility and reliability to be in touch .

In Turkey, modern operating system for healthcare services, family medicine, was first conducted in Düzce in 2005. Today, in 23 provinces equivalent about nine million people are benefiting from this. Approximately 20% of Turkish people were registered to the family doctors. Primary care services are put at the beginning of public agenda due to increase the family medicine practicing, this leads to make care attractive and thus provide easy and widespread of these services. Successful of this system leads to decreasing number of patients visiting doctor or hospital and reduce overload at hospitals.

Healthcare is being one of the four sectors, in the national project plan for the Russian government in 2006, which aims to improve these sectors. \$3.2 billion is approved to be devoted for healthcare to cover increasing salary for doctors and nurses, also to purchase new equipment for clinics and the building of eight high-tech medical centers in Russia's outlying regions.

Also in the UAE especially in Dubai, the government aims to optimize overall luxury of its people. The strategy in UAE government works to provide patient-specific care. The healthcare providers in Dubai provides most popular medical services which includes immunizations and vaccinations, psychiatric treatments, medical fitness examinations, community services (such as marriage and family counseling), adult and infant yoga therapy, rehabilitation, and education on health and nutrition [5].

1.2. E-Healthcare Challenges

E-healthcare systems faced many types of challenges; this research concentrate on the major challenges can be heavily affected to the E-healthcare system.

➤ Network for the system

The design of the network is the most important thing for establishing any type of healthcare system for it is the coordinator of how the data will be transferred from the patient to the healthcare provider, and how the members of the system communicate together in a simple way. For data transfer, many issues should be considered:

- Throughput of the network.
- End to End delay for transfer data.
- Packet Delivery Ratio.
- Drop Packet.

➤ Cost

The cost to establish healthcare system should be taken into consideration. Reducing transfer cost of the data will make the system more desirable and economical.

➤ Decision making

Decision making is an important part to design smart health care system; this helps the healthcare provider to be faster to response for any abnormal case

for the patient.

➤ Reliability

Healthcare system should be reliable; it gives the system better performance and makes the system always in touch to all members of the system.

➤ Scalability

Scalability for any healthcare system very important, means the system accept verses number of members.

1.3. Literature Survey

This section deals with some of the previous related works to MANETs technology and E-Healthcare systems, that are studied and proposed by number of researchers.

1- Sumeet Priyadarshree Dash in 2007[2], presented health decision support system for rural india. The system have five major modules:

- Module of SMS technique for sending and receiving messages between mobile phone and server.
- Establishment and maintenance the database through database design module.
- SMS analyst which is used to provide validation and authentication of received and sent SMS messages.
- Disease Surveillance Module for collection, save and analyze the surveillance data.
- Query Manager for generation of customized reports.
- Diagnosis Module for resolving user diagnosis query.
- Location Tracking Module for detection of concerned location.

The architecture for this system has three functional units Surveillance unit, Diagnosis unit and Emergency controller. The mechanism of the proposed system is that, the message sent from the patient by using GSM, when the serve received the message, it will be interpreted in two phases, parsing and classification. The parsing process check the message if it is real or not, if the message is unreal it will be discard else it will go to the classification process. In the classification part the message will be analyzed to three possible cases

Surveillance, Diagnosis and Emergency. Finally the researcher for this work used the decision tree for the diagnoses.

- 2- Asma Shaheen and Waqas Ahmad Khan in 2009[1], suggested an e-healthcare system for the diabetic disease. Their system included all requirements for design any healthcare system as (database, web server and user interface). The proposed system depends on the data entered by the patient from the web site of the system; after data entered it will go to the main server of the system. The server works to analyze these data and take the action, if the data in the critical case directly an alarm message will be going to the emergency department also to the doctor. If the data can be solved by the server, the server will give the patient directly the medicine or pass it to the healthcare provider to give the patient medicine or appointment. The main goal of this research is to reduce the unnecessary visits for the patient to the hospital and make the connection between the doctors and their patients more easy and available at anytime and anywhere.
- 3- Mohammad Ariful Basher and Palash Chandra Roy in 2009[3], studied the e-healthcare system in their country (Bangladesh) and in development countries then made comparison between them. From this they proposed e-healthcare system depends on smart E-Health card, this card contains all information for the patients, doctors, nurses and every one member in the system. Also proposed smart device (PDA) can be integrated with the card instead of PC or Laptop to provide flexibility when the user uses his card. The main goals for this research is to support the e-health care system in Bangladesh by making the interaction between doctors and their patients more easy in the appointment field, diagnosis field and to access all information.
- 4- Rifat Shahriyar et al. in 2009[6], had designed E-Healthcare system. The system was designed to monitor the patient and send his case to the specialist doctor by using reliable internet or using GPRS, 3G. This system applies two servers, Patients Personal Home Server [PPHS] and Intelligent Medical Server [IMS]. The system used was designed that the central node in the patient body collected the data from the sensors then sent it to the smart device PPHS, this server analyzed the data and decided if this data is necessary to be sent to the

IMS or not. If the data sent to the IMS, it will analyze by using the data stored in the database for this patient and gave a decision to be taken into account.

- 5- Mervyn Charles Abrahams in 2010[7], proposed E-Healthcare system for the diabetic diseases, the system included three main parts the mobile diary application, the mobile social networking application, and the website interface. The first part is a smart device used to enter the readings of diabetic disease to the system. Second part is a social networking used to support the system and can be connected with other social networks. the third part focus on the web site of the system, for the web site is a tool that make the members and all things communicate to the system will be directly related to the database and server of the system. The researcher used the Appach Server to design the server and also used My Sql and php my admin to design the database. Finally used the php.net to design the web site for the system.
- 6- Stefan Plank, Thomas Nowotny and Thomas J. Lampoltshammer in 2011[8], presented E-Health monitoring system for Elderly In-home. This system divided into three main parts data gathering and transmission [DG&T], monitoring and surveillance [M&S] as well as management, control and storage [MCS]. the proposed system work on putting sensor nodes in the patient's body and monitoring for example the heart rate and movement for the patient, and put at least one camera in the room of the patient, if any emergency case read from the sensors directly the camera take capture for the patient and send it with the data to the healthcare provider. This research aim to give the doctor all information when his patient has abnormal case.
- 7- Akshai Aggarwal, Savita Gandhi and Nirbhay Chaubey in 2011[9], analyzed performance for three main protocols of MANETs DSR and AODV reactive protocols and DSDV proactive protocol. The analysis in this research based on different metrics as PDF, NRL, End to End Delay and throughput used high mobility case under low, medium and high density scenario. The researcher varied the number of nodes from 25 (low density) to 200 (high density) in a fixed topography of 1000 x 1000 meters, and they founded AODV performance is the best considering its ability to maintain connection by periodic exchange of information. Also in the throughput field AODV and DSR perform better than DSDV even when the network has a large number of nodes. Average End-to-

End Delay is the least for DSDV and does not change if the numbers of nodes are increased. Finally they concluded that AODV routing protocol is a best choice for MANETs except in the NRL because the NRL in the AODV go to increase with increase in the number of nodes.

- 8- Nisarg Gandhewar and Rahila Patel in 2011[10], determined the performance of most popular AODV in MANETs based on various performance metrics such as PDR, End to End delay and packet loss, by used NS2 simulation. The researchers depend on varying number of nodes in the network, and they founded there is nonlinear change in the values of these metrics also we realized working and control messages involved in AODV protocol.
- 9- G. Jose Moses. et al. in 2012[11], evaluated the performance of the MANET routing protocols AODV, DSR, and DSDV used NS2 simulation based on CBR traffic. The comparison between these routing protocols showed that the scalable performance was effective to the performance evaluation mechanism developed by the project. Average end-to-end delay, Packet delivery ratio, Routing load and Throughput are the terms for the comparison between three routing protocols. The simulations have shown that performance of a routing protocol varies widely across different performance differentials. The researchers proved that both AODV and DSR perform better in simulations than DSDV. Therefore, they concluded that AODV and DSR better than DSDV for the CBR based traffic in MANETs environments, also AODV and DSR may be used as a base protocol when they talk of developing a new protocol for Ad-hoc networks and the future research should be focused on optimizing and implementing a new protocol for MANETs.

1.4. Thesis Aims

This research aim's to study and analysis performance of E-healthcare system for both patients and their doctors, by designing:

- A network to make the interaction between all members in the system more easy and transfer the data from patients to their doctors more economical and flexible by implementing MANETs technology.
- Decision making for the system to help both patients and healthcare provider.
- Finally the system should be reliable and scalable.

1.5. Thesis Outline

This thesis is divided into five main chapters. A brief description of all these chapters illustrated below:

Chapter One: The chapter describes the background of thesis topic, also the challenges of E-healthcare system is explained. In addition, the related work for number of researches that deals with thesis topic has been described. Finally the objects of this thesis are listed in the chapter.

Chapter Two: The concepts of the decision support system and one of its applications (E-Healthcare) has been mentioned in this chapter. Moreover, Mobile ad-hoc network is described through the chapter.

Chapter Three: The chapter talks about the studying and the analyzing of the proposed network. Using the results we got in this chapter, we published a paper in International Journal of Computer Engineering & Technology (IJCET) titled **(Behavior Analysis of Routing Protocols for a Health Decision Support System)**.

Chapter Four: The chapter demonstrates the designing of the proposed system using high level languages C# and ASP.NET. In addition, the rule of that is selected for the decision support system is presented.

Chapter Five: Conclusion and future work are introduced in this chapter.

CHAPTER 2

THEORETICAL CONCEPTS

2.1. Introduction

This chapter deals with two main parts, the first part will describes the decision support systems (DSS) and its applications, DSS is a set of computerized information system used to support activities of decision-making for business and organizational. Correct design of the DSS helps the decision makers to compile useful information from raw data, documents, personal knowledge, and/or business models to determine and solve problems and make decisions. DSS can be used in different fields as a business field and medical field. Also this chapter will explains the e-healthcare system one of the DSS application. the second main part for this chapter will describes the mobile ad-hoc networks (MANETs) and its applications, MANET is a collection of wireless devices connected together directly without any central device, MANET can be used in various fields as a military and medical.

2.2. Decision Support System

Decision support system is a tool based on computers that are used to support difficult decision-making and solving the problems. Decision support systems are computer-based systems gives the human help for making better decision. DSS works and serve the operations, administration, and planning levels of an organization and assist to give decisions, which may be quickly changing and difficulty specified in advance. Decision support systems may be either fully human, computerized or a combination of both [12].

2.2.1. Decision Support System Architecture

Decision support systems are not far different from other systems and require a structure method. DSS has three main levels:

1. Technique levels.
2. Members.
3. The developmental methods.

1- Technique levels have three levels of hardware and software :

- Specific DSS.
Specific DSS is the application that user will be used it, and it allows the decision maker to make decisions in a specific problem area. The user can deal with that specific problem.
- DSS generator.
DSS generator includes hardware and software environment that makes people to easily develop specific DSS applications. This level makes use of case tools or systems.
- DSS tools.
DSS tools have hardware and software in lower level, DSS generators including function libraries, linking modules and special languages.

2- Members have five roles in the development cycle of DSS the end user, an agent, technical supporter, experts and developer.

3- The developmental methods for a DSS system should be frequently. This makes the application to be redesigned and changed at different periods. The first problem is used to design the system then tested and reviewed to get the desired outcome [13].

Components of any DSS divided into three main parts:

- The database used to store all information related to the system.
- The model means that which field the DSS will be used.
- The user interface is a way enable the members of the system interact with the system [14].

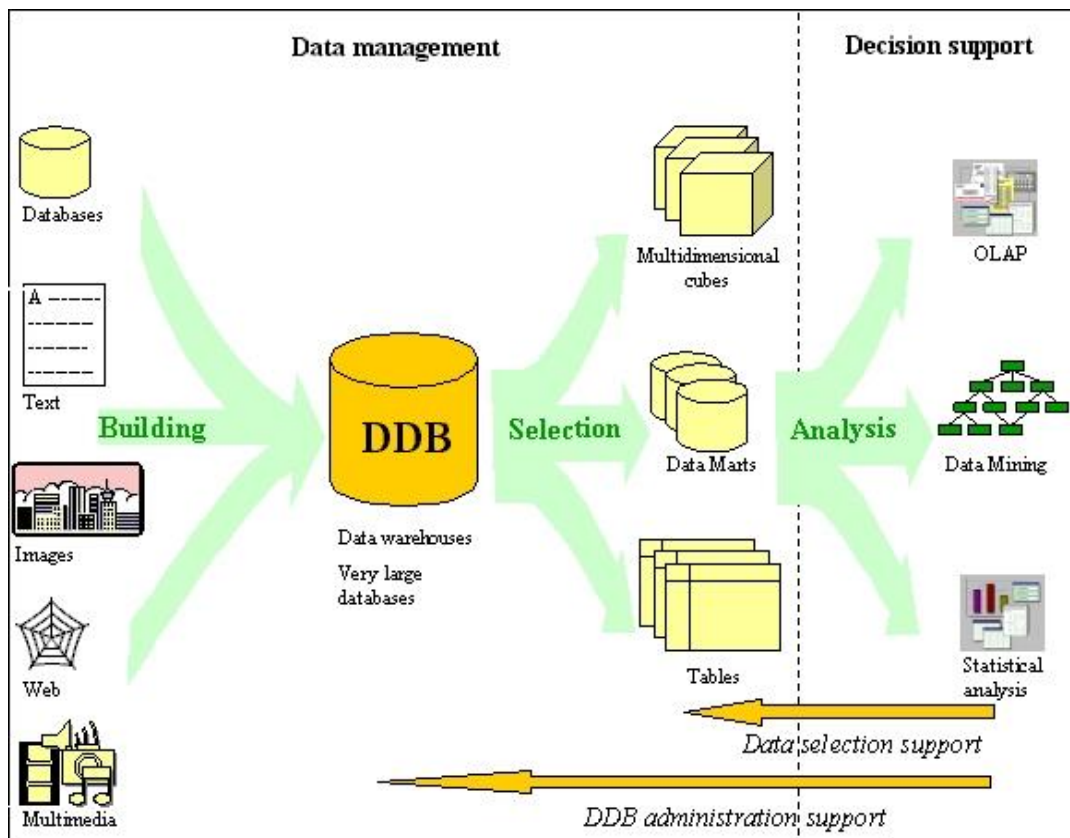

Figure 1: Decision support system

2.2.2. Decision Support System Applications

Decision support system used in a lot of fields, below some of fields integrated with DSS will be listed.

- A DSS used in medical field.
- DSS has been used to forecast the demand for water in particular areas.
- DSS also used in integrating weather conditions and air traffic management.
- Also, many businesses have integrated with DSS [15].

2.3. E-Health Care Decision Support System

In this section concepts and applications of an e-healthcare system will be described. Then the components of an e-healthcare system and its tiers will be explained.

2.3.1. Concepts of E-Healthcare System

E-healthcare, introduced as self-monitoring/testing, in order to allow health care provider to monitor a patient remotely using different technological devices.

Managing chronic diseases or specific conditions, like diabetes or heart disease, are the primary usage for this method. The benefit from these services is to providing health outcomes similar to traditional person patient meetings to the doctor, providing better satisfaction to patients, reduce the cost. For capture and transmit the biometric data like a heartbeat and temperature to the doctor, the sensors are used in remote E-Health monitoring. This may be done in either real time or the data will be stored then send it. Examples of e-health monitoring include:

- Home-based nocturnal dialysis.
- Cardiac and multi-parameter monitoring of remote ICUs.
- Home Tele-health.
- Disease management.

In other hand E-Healthcare system helps to monitor important data of a patient continuously like heartbeat, temperature etc., by the help of sensors which captures these data then send it to the health care provider in case of some abnormality of these data [16].

2.3.2. Applications of E-Healthcare System

1- Heart Diseases

Time may be one of the major parameter to be taken in consideration in cardiovascular disease, which has a relation to heart and blood vessels. About 30% of deaths because of heart disease according to world heart organization. One half of these die before reaching the hospital, therefor it is clear that, this kind of patients should have a continuous monitoring and effort the care requirements when needed. One of these requirements is the WBAN, which is the key technology provides the real time continuous monitoring and transmit data between patients and physicians to give the patients all required treatment as soon as possible.

2- Asthma

WBAN can help asthma patients by monitoring allergic agents in the air and providing real time feedback between physician and patient. The server collects the real time data from network of air quality stations and alarm physician – patient if it finds anything allergic to the patient.

3- Cancer Detection

One of the biggest threats in human life is the cancer, which increased rapidly in recent years. To differentiate between ordinary cells and cancerous cell WBAN with a set of sensors can be used in this field.

4- Diabetes

More than 220 million people all around the world have diabetes and 1.1 million people died because the diabetes in 2005 as reported in World Health Organization (WHO).

Below some of the complications may be occurs due to the diabetes

- Amputations.
- Blindness.
- Kidney disease.
- Stroke.
- High blood pressure.
- Heart disease.

A WBAN can be used to help for treating diabetes, by providing a more consistent, less complex and accurate method for monitoring glucose levels in the body.

5- Artificial Retina

The implantation of Optoelectronic Retinal Prosthesis (ORP) chips into the back of human eye can helps blinds and/or patients with low vision to see normally [17].

2.3.3. Components of E-Health Care System

E-healthcare decision support system provides a lot of benefits for both patient and doctor. The e-healthcare decision support system consists of:

- Main Server.
- Various server/client in various zones.
- Telemedicine.
- Smart devices.
- Telecommunication.
- HER.

- Mobile van.
- Research and academics institutions.
- Domestic health professionals and their associations.
- Consumers, patients and their associations.
- Paraprofessional training institutions and electronic medical colleges for the training of E-Health system.
- Non-governmental organizations.
- Telecommunication and health decision-makers at the central
- E primary, secondary and tertiary care institutions, manned by medical and paramedical personnel.
- Computer literate personal at Central as well as difference zones.
- The private sector, including foundations and industries related to health and ICTs.
- E health management information system.
- The media [18].

Any E-Healthcare system has three main tiers. The first tier is a patient side that means the sensors attached to the body of the patient to reading the data that should be monitored for this patient and collects these data by the smart device (personal server). The second tier, is a medical server side (server and database) using to support the system and user interface. Finally, the third tier is a healthcare provider side. All this will discuss below.

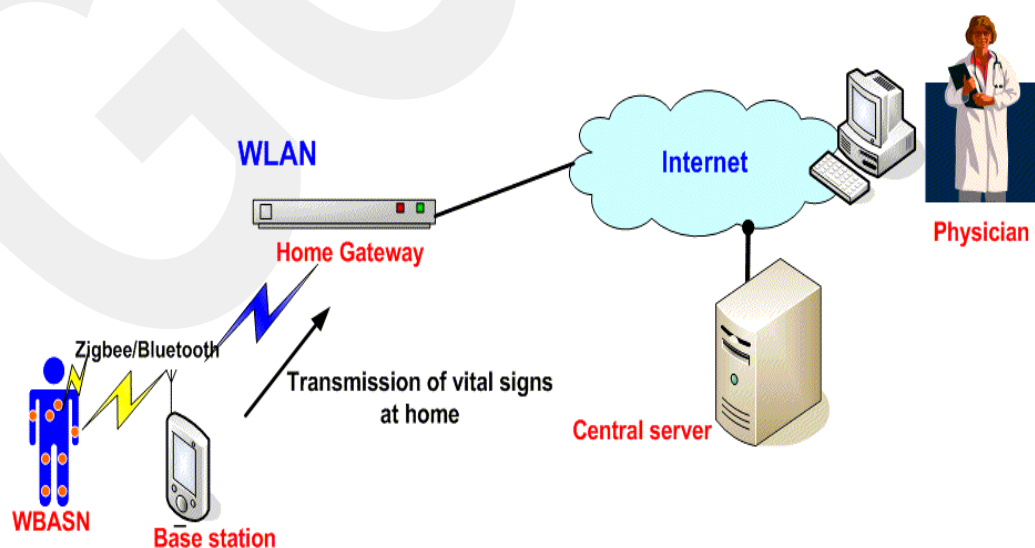

Figure 2: E-Healthcare system

2.3.3.1. Patient Side

Patient side includes sensors attached to the body of the patient and the smart device which collects the data captured by the sensors then sends it to the medical server.

A) Sensor Nodes

Monitoring the patient, the sensors should be attached to the body of the patient; these sensors work to capture various physiological signals of medical interest. Each node is capable of sensing, sampling, processing, and communicating physiological signals. For example, to monitor activity of the heart, ECG sensor can be used, to monitor muscle activity, EMG sensor can be used, to monitor brain electrical activity EEG sensor can be used, to monitor blood pressure, blood pressure sensor will be used, to monitor trunk position tilt sensor can be used, also breathing sensor for monitoring respiration. Sensor nodes can be wireable send data or wireless. In the recent years, e-healthcare system focused on the sensor that sends data in the wireless way to provide mobility to the patient [19].

B) Components of Sensor Node

Sensors node have three main components:

1. Microcontroller

This part is used to control the monitoring, that means, the sensor in the deactivated case, will be led to the sleeping mode. In addition, the data read by the sensor it is along signal the micro controller has ADC using to convert the analog signal to digital signal.

2. radio transceiver

This part used for generating radio waves, it's enable the sensor to be connecting with control sensor or with personal sever by wireless way. For this part many types of radio waves are used like bluetooth and zigbee.

3. energy source like battery

Last part for the sensor node is the battery, it is like a heart for the sensor, it provides the power to the sensor. This part can be reachable from the external connector [20].

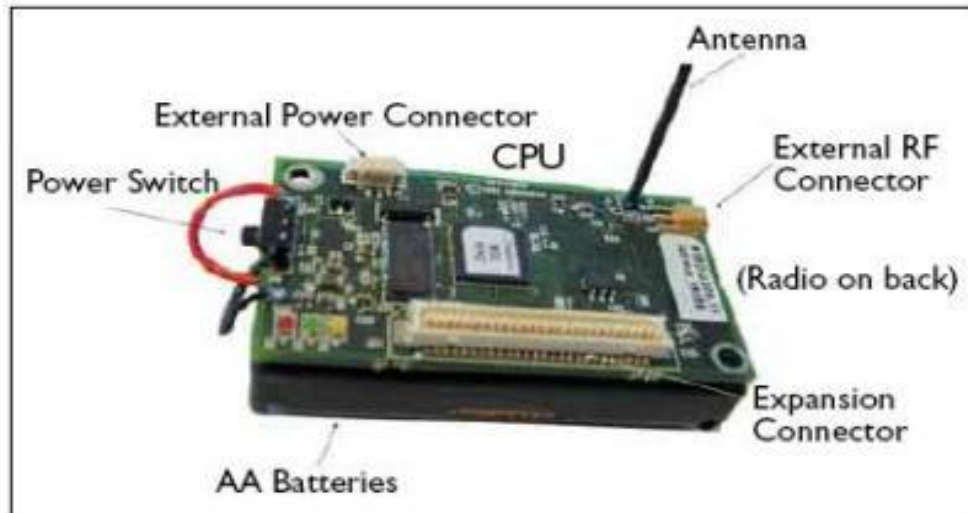

Figure 3: Components of sensor node

C) Sensor Nodes Connectivity

The sensor captures the data from patient body, and then will be ready to send this data to the personal server. If the sensor nodes are a wearable, it will directly send the data to the personal server. Otherwise, it will be wireless sensor nodes, this type of nodes send the data in two ways. Firstly, the sensor sends the data directly to the personal server. Secondly, the sensor sends the data to the coordinator node (sink node). The sink node is used to coordinate the data transfer from the sensor nodes to the personal server to send it to the medical server. Sensor nodes are connected together using one of different types of topologies like, star, mesh, tree or any type of the topologies that depend on selecting the best suitable one for the system. The technique for collecting data from the sensor nodes then sending it to the personal server in a wireless way called wireless body area network [WBAN] [21].

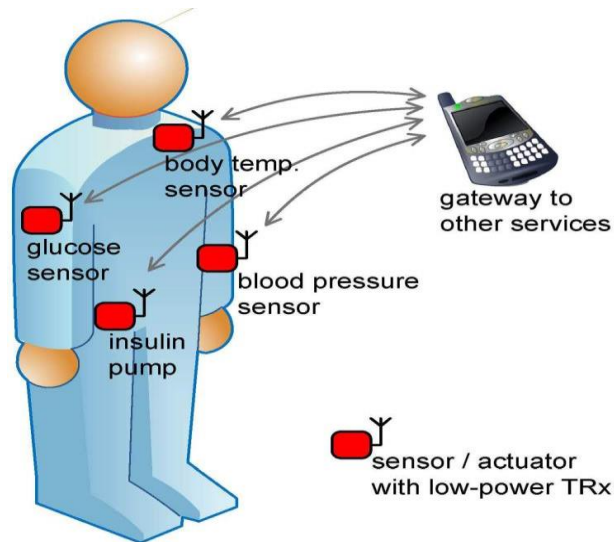

Figure 4: WBAN

D) Personal Server

The patient's personal server can be a personal computer or mobile devices such as cell phone/PDA. Personal server received data from the sensor nodes of the WBAN then send it to the medical Server. If the personal server is a personal Computer it will communicate with the MS using Internet. Otherwise, it will be a smart device communicates with the MS using GPRS / Edge / SMS. To establish communication between personal server and WBAN, Zigbee or bluetooth capability is required depending on the platform. The responsibility for sensors configuration is managed through personal server including node registration (type and number of sensors), initialization (e.g., specify sampling frequency and mode of operation), customization (e.g., run user-specific calibration or user-specific signal processing procedure upload), and setup of a secure communication (key exchange). Also the personal server has capability to send the position of the patient in case of been outside the door by using GPS technique. The personal computer or cell phone/PDA is connected easily to a single MS without any problem [22].

2.3.3.2. Medical Server Side

The medical server is the most important part of any E-healthcare systems because it is considered as the heart of the system. Medical server is a communicated ring between patient side and healthcare provider side of the system. The medical server stores electronic patient records in a database and supply the authenticating registered health monitoring system users and accepting session uploads, summarizes

and automatically analyzes the physiological data received from patient side. When abnormal conditions are detected, the medical server will be responsible for generating alerts to the physician and emergency and providing the better solution. Medical server interacts with three main parts, the database, decision maker and user interface, all these parts are described next [23].



Figure 5: Medical server for E-Healthcare system

A) Database

The database of any e-healthcare system is used to store information of all members in the system. For example, the database saves all information of the patients, doctors and nurses. The medical server can access the database of the system and can interact with it. All readings from patient side are collected in the medical server, and will be saved if it is necessary in the database. In the other hand, the way for the medical server to access and interact with all information of the E-healthcare system will be through the database.

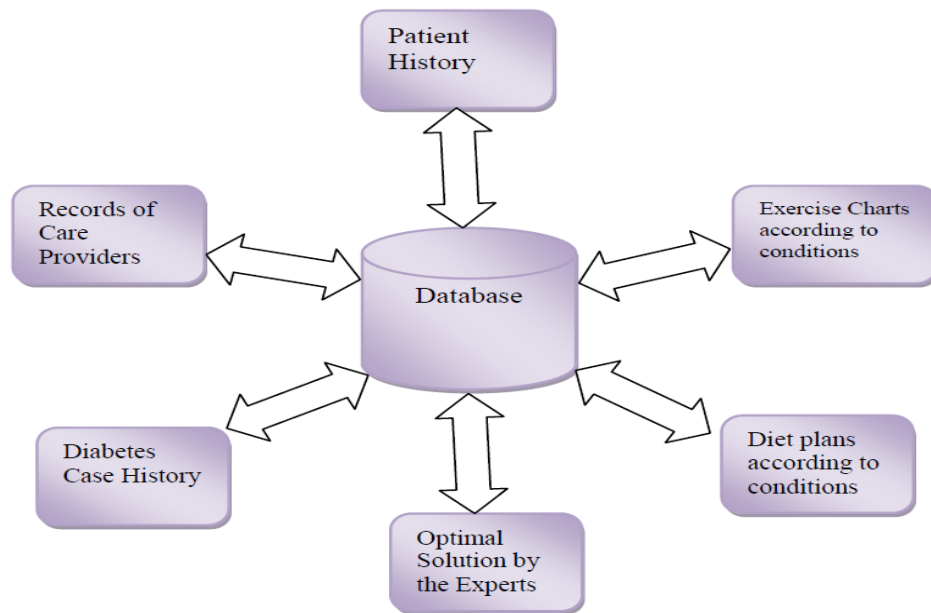

Figure 6: Database for E-Healthcare system

B) Decision Making

Decision making is a rule used by medical server to analyze the physiological data coming from the patient. Decision making makes the medical server to help the doctors in the healthcare system for taking an action for patient case. In another words, reducing the burden on the doctor, for example reducing the number of patients visiting to their doctors. Recent researches focused on the rules that were supporting the decision maker; the types of the rules are summarized below:

- 1- Data mining technique to analyze the data then take an action.
- 2- Neural network to support a decision maker.
- 3- Fuzzy logic for analyzing the data.

In other hand, when physiological data are read by the sensors that are attached on the patient's body, the data will be sent to the medical server. Medical server works on analyzing these data based on the type of the algorithm which is used in the system. After analyzing these data and getting the result, the result will be sent to the concerned side such as healthcare provider. Fig.7 below explains the scheduling process for decision maker of a diabetic healthcare system [2], [6].

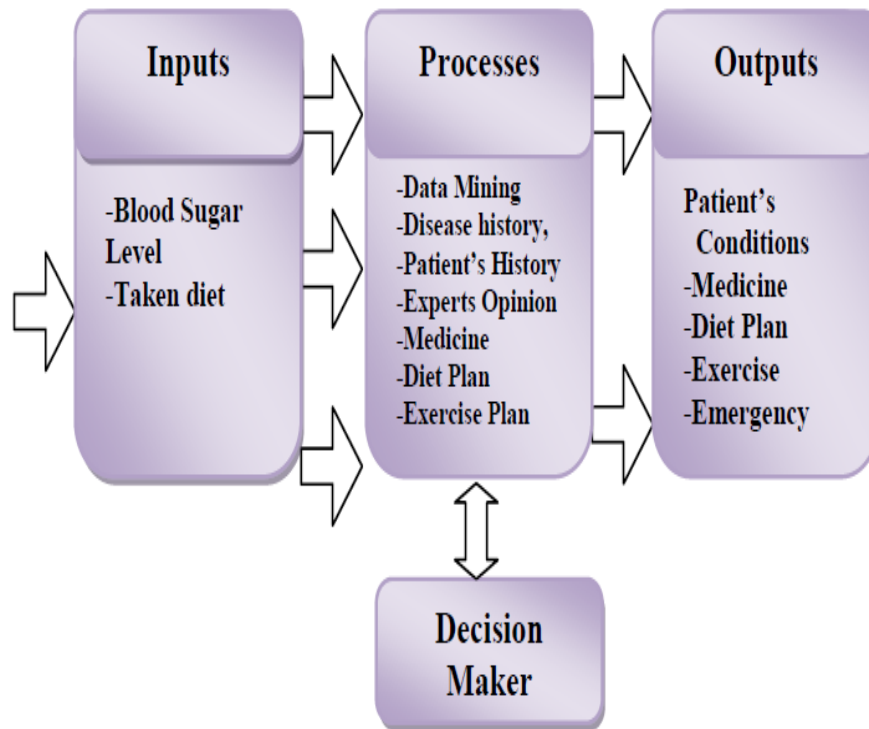

Figure 7: Decision maker process

C) User Interface

User interface is a tool used to enable all users to interact with their system. User interface is considered such as web site or mobile application used to provide users ability to access the system in an easy way. The accessibility to user interfaces should be easily and self-explaining if they are used by the patients directly, also it should be advanced enough for the healthcare providers. User interface preferably be reachable via external connections. Finally remote access to user interface is important as well.

2.3.3.3. Health Care Provider Side

Healthcare provider is a third tier for any e-healthcare system. This tier consists of number of people who take care of patients. Health care providers can be doctors, nurses, trainer, paramedics and pharmacists. When the healthcare providers' team works effectively and efficiently, they can improve the quality of patient life.

2.4. Mobile Ad-Hoc Networks

Mobile Ad hoc network (MANET) is a collection of wireless devices communicating together without any centralized control. The recent research has been focused on the

MANETs technology due to it's the availability of small and inexpensive wireless communicating devices. MANETs could be used in different applications such as medical, mobile classrooms, battlefield communication and disaster relief applications [24].

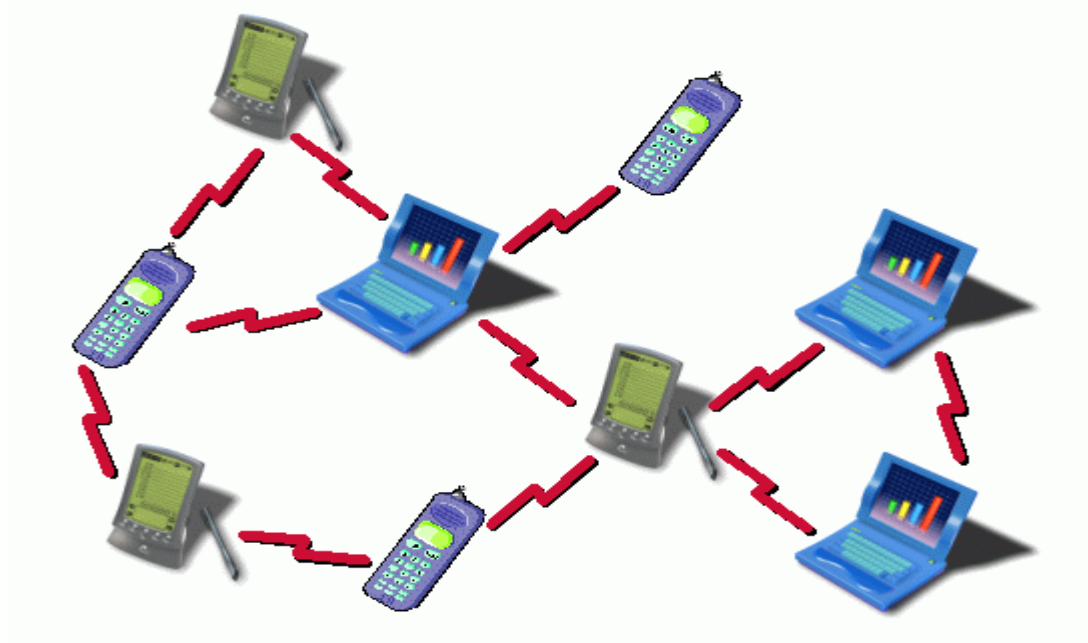

Figure 8: Mobile ad-hoc network

2.4.1. History of Mobile Ad-Hoc Networks

The life cycle of ad hoc network could be characterized into three generations first, second and third. The present Ad hoc networks systems are the third generation.

In 1972 the first generation of ad-hoc network founded that was called PRNET (Packet Radio Networks), at the same time for founding ALOHA (Ariol Locations of Hazardous Atmospheres) and CSMA (Carrier Sense Medium Access). At this time mobile ad-hoc network used by the Defense Advanced Research Project Agency (DARPA) in the military field.

In 1980 the second generation of Ad hoc networks has been defined. At that time the SURAN (Survivable Adaptive Radio Networks) has been enhanced and implemented ad-hoc network systems as a part of its program for providing mobile networks to the battlefield in an environment without infrastructure. Also, this program has been proved to be beneficial in optimizing the performance of radios by making them cheaper, smaller and resilient to electronic attacks.

In 1990 the third generation has been introduced, and the idea of ad hoc networks arrived with notebook computer and other communication tools in the life. The researches especially IEEE 802.11 committee in this time proposed the idea of mobile ad-hoc technology, and starts to look in possibility of developing ad-hoc networks in different applications area [25].

2.4.2. Architecture of Mobile Ad-Hoc Network

Wireless networks can be classified into two types based on their system architecture. Infrastructure is the first one and ad-hoc network is the second. The main different between them is infrastructure networks have central control and nodes, but the ad hoc networks are independent from central node. In the infrastructure networks, node can't connect directly with other node in the same cell and other cell. Central node works to control message. Message is sent to the central node and then the central node delivers the message to the destination node. If a node wants to communicate with other node located in other cell, the central node will relay the message to other central node, which has control over desired cell. The central's nodes can be connected via wireless way or wired. The main problem in infrastructure network, if the central node destroyed, all nodes in this cell can't perform any connection.

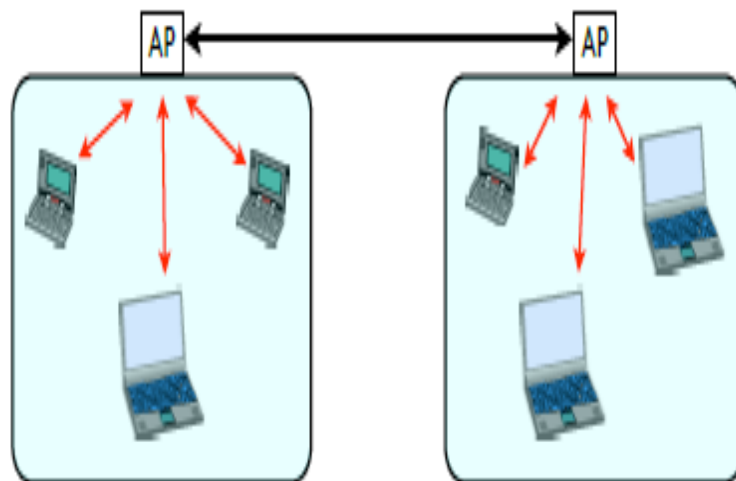

Figure 9: Infrastructure network

Ad hoc networks have a different approach for nodes connections. Fig.10 example for ad-hoc network, Where N1 desires connect with N5. N5 outrange transmission of

N1, so N1 should hop the message to N4-N2-N3-N5 OR N2-N3-N5. The best route will be selected based on routing algorithm. The main advantage of ad-hoc network is if N4 leaves the network, N1 still has a route to N5. Therefore ad hoc networks are more robust than infrastructure. MANET is the modern generation of ad-hoc network, but the work of MANETs like the work of ad-hoc network just the difference between them, MANETs provide motility to the nodes in the network, this provides dynamic topology for the network [26].

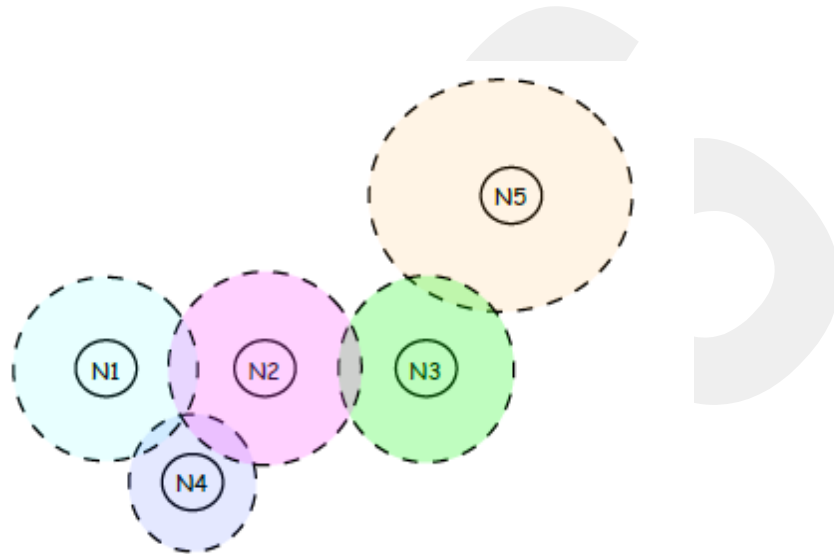

Figure 10: Mobile ad-hoc network transmission range

2.4.3. Mobile Ad-Hoc Networks Challenges

- Packet losses

May be occur, due to mobile ad-hoc network is an infrastructure less means there is no centralized control and every device can communicate directly with other every device. This provides difficulty to detect and manage the faults.

- Scalability

The scalability is important thing in MANET as it is used in medical or military communications, due to network size grows according to the need, therefore each mobile device in the network should be has ability to handle the density increase of network and to accomplish the task.

- Security

The Security issue in MANETs has to be addressed. High degree of security is requiring in some applications of MANET like Military and Confidential Meetings to prevent attack of enemies and active/passive eavesdroppers. Also, the changing in topology of the network makes it very vulnerable to infiltration, eavesdropping and interference [25, 27].

- Routing

Routing packets between source and destination nodes becomes a challenging task due to the continuous changing in topology of MANET's. Most of routing algorithms has been implemented to solve this problem. In addition the random movements of nodes within the network give challenge to the multi cast routing [28].

2.4.4. Mobile Ad-Hoc Network Routing Protocols

The main issue in transfer the data from node to node in MANETs is a routing protocol. In the other hand when node in the MANET desire to send data to another node in the same network, the routing protocol works to discover the path from source to destination and decided which path is the best.

MANETs have many types of routing protocols; they are classified into three main parts:

1. Proactive protocols

Proactive routing protocol means every node maintains routing information of the network continuously. This is happened by flooding network periodically to discover any possible change in network topology based on network status information. Examples of Proactive Routing Protocols are:

- a) Global State Routing (GSR).
- b) Hierarchical State Routing (HSR).
- c) Destination Sequenced Distance Vector Routing (DSDV).

2. Reactive protocols

In this routing protocol each node maintains information paths to the destination node only which it's active. For each new destination route search

is needed. Quickly change wireless network topology may be breaking active route and result new route search. Examples of Reactive Routing Protocols are:

- a) Ad hoc On-demand Distance Vector Routing (AODV).
- b) Dynamic Source Routing (DSR).
- c) Location Aided Routing (LAR).
- d) Temporally Ordered Routing Algorithm (TORA).

3. Hybrid protocols

Hybrid routing protocol is a combining of globally reactive and locally proactive states. Hybrid routing algorithm is ideal for Zone Based Routing Protocol (ZRP) [29].

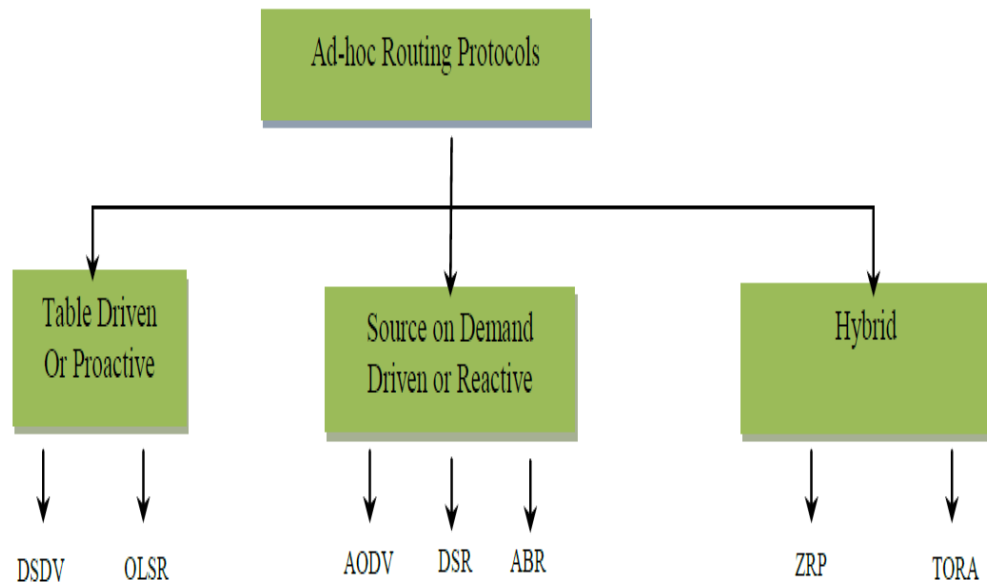

Figure 11: MANETs routing protocols

2.4.4.1. Destination Sequence Distance Vector

DSDV is a proactive routing protocol based on the idea of the classical Bellman-Ford Routing Algorithm. The main contribution of the algorithm was to solve the Routing Loop Problem. This protocol depends on table-driven means that every node in the network maintains a routing table to send data from source to destination. DSDV is a suitable routing protocol for ad-hoc network with small number of nodes, but it has some disadvantage, that this protocol so effect in dynamically change of network because it need regular update for the route path, addition to its performance is not good with large number of nodes in the network [30].

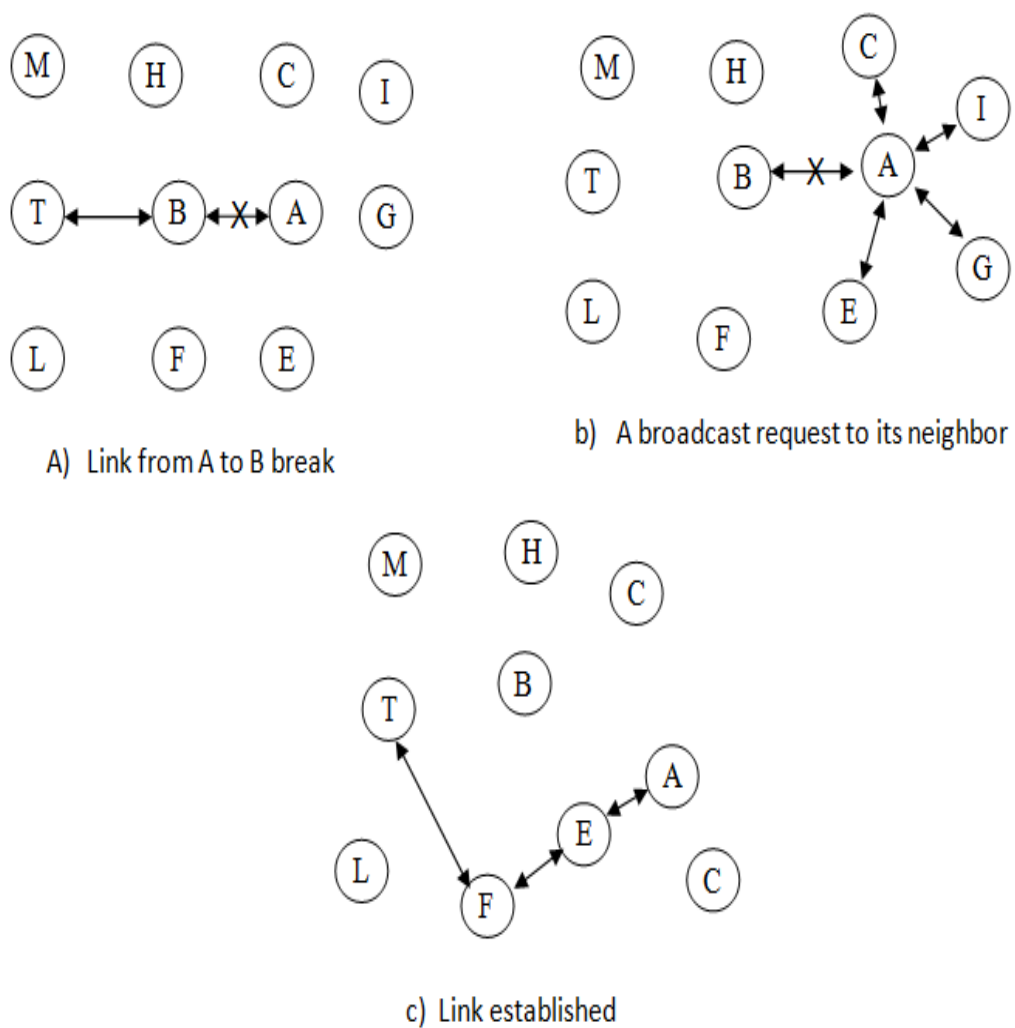

Figure 12: Creation new route path for node A

Table 1: Route Path Update

Neighbor	Hop number	Via node	Update Time
C	2	H	1756
I	3	A	805
G	3	E	1050
E	2	F	1860

In Fig.12 and Table.1, The link between node A and node B was broken, for that node A search for a new path to connect with node T by its neighbors and select a new route path depend on less number of hops and the last update for route table .

2.4.4.2. Ad-hoc On-demand Distance Vector

AODV protocol is both an on-demand and a table-driven protocol discover routes only as needed. AODV is a reactive protocol, although it still uses features of a proactive protocol. AODV takes the interesting parts of DSR and DSDV, in concept of sequence numbers and sending of periodic hello messages from DSDV and it uses the concept of route discovery and route maintenance of DSR. The protocol uses different messages to discover and maintain links. When a node desire to connect with another node, it checks if there is a valid route path to the destination, the node use this route to connect with the destination node. If not valid , the source node send a route request (RREQ) to its neighbor, if this neighbor has a route to the destination or it is a destination ,it will reply (RREP) to the source node to send the data as shown in Figs.13,14. If there is RERR receive by the source node that mean the source node go to discover a new path to the destination [31].

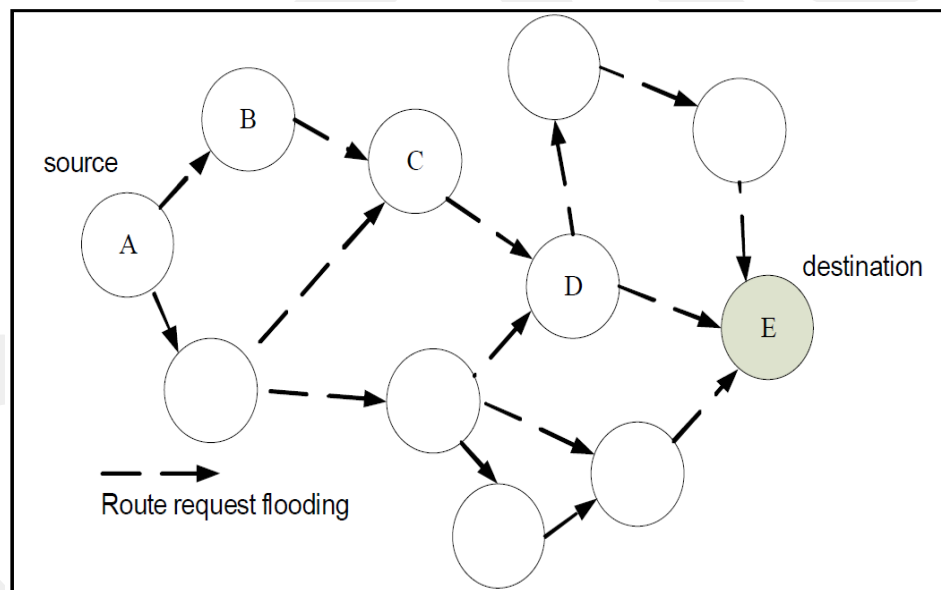

Figure 13: Route request (RREQ) flooding

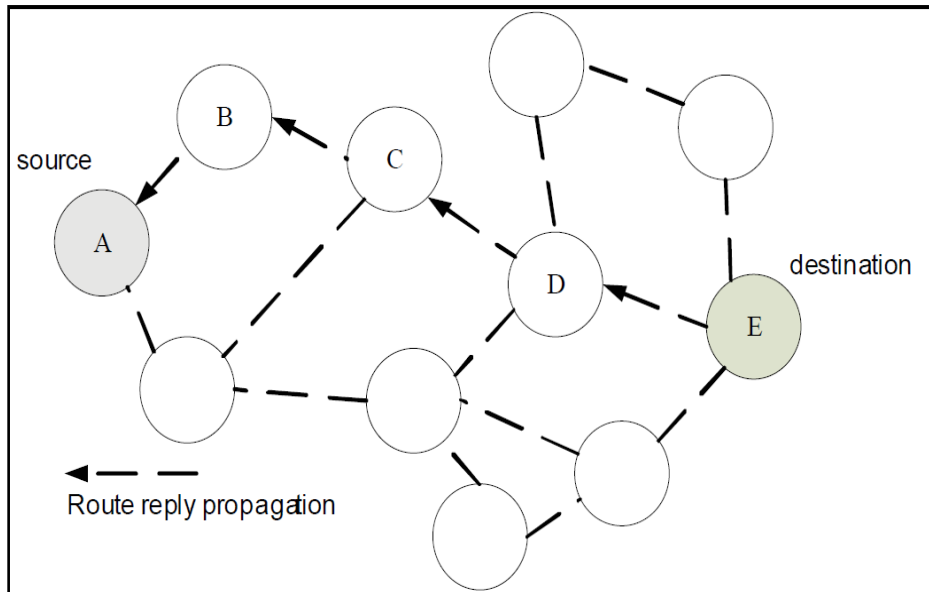

Figure 14: Route reply (RREP) propagation

2.4.5. Mobile Ad-Hoc Networks Application

- Communications and operations in military.
- Policing and firefighting.
- Supporting doctors and nurses in hospitals.
- Home/office wireless networking.
- Conferences, meeting rooms.
- Universities and campus settings.
- Multi-user games.
- E-commerce, electronic payments anytime and anywhere.
- Sports stadiums, trade fairs, shopping malls.
- Networks of visitors at airports.
- Outdoor Internet access.
- Data tracking of environmental conditions, animal movements, chemical/biological detection [32].

CHAPTER 3

PROPOSED NETWORK

3.1. Introduction

This chapter describes the network proposed for DSS E-healthcare, this network based on MANETs that provide free wireless for transferring data from patient's side to the doctor and provide scalability for the network. The simulation that is selected to simulate this network is NS2 simulation. NS2 simulation works on testing the best routing protocols for the network which is based on four metrics, (PDR, End to End delay, throughput and drop packet).

3.2. Simulation Environment

In this kind of simulations, a best version 2.34 of NS-2 has been used in this work. Ns-2 is a discrete event simulator targeted at networking research. It began as a part of the real network simulator and it is evolved through an ongoing collaboration between the University of California at Berkeley and the VINT project [33].

The selected NS-2 is considered as the advanced platform since NS-2 is a very potent, widely used, and open source simulator. NS-2 provides effective and suitable ways to arrange networks and nodes. NS-2 has been commonly used in MANETs simulations.

The excessive improvement on using ns-2 is that it is open source, famous and generally used by researchers. This means that anybody willing to fulfill its explanation for executing ns-2 simulations can use the same code.

Two languages are used in NS-2, C++ and Otcl. Users can use Otcl language to simply adjust the restrictions of protocols and algorithms executed in C++. NS-2 also allows us to have the benefit of the abundant existing source codes.

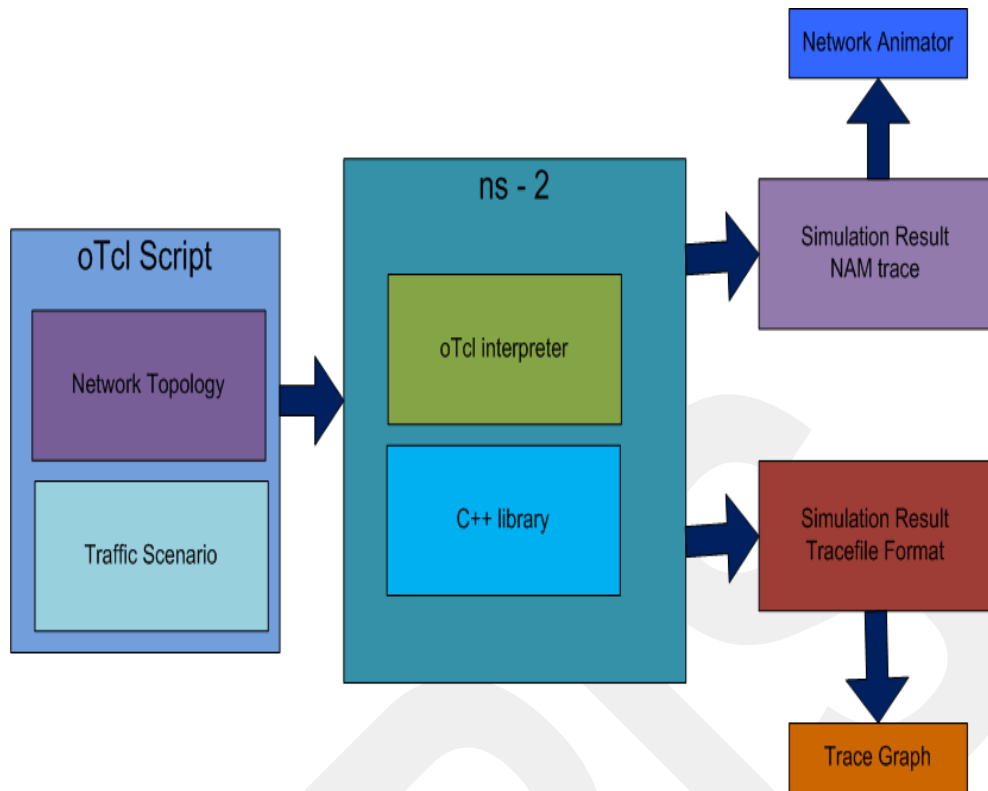

Figure 15: Software architecture for NS2 simulation

3.3. Network Topology Proposed

Network in this research deals with healthcare field for the DSS and consternate on transfer data, where number of patients are placed in the same local area and each one of them has a smart device like mobile or PDA, this device is designed to transmit the data from the patient to the doctor. This data is captured by the sensor attached in the body of the patient as seen in chapter 2. Also this network has high scalability because at any time, the network can have 20 patients and after little time the number of patients will be extend to be 80 or 120. This field was supported by MANETs technology that provide free mobility and free wireless transmission of data by covering 1000m*1000m. In the other hand, patients are placed in one cluster that covers 1000m*1000m area, with one gateway to connect this network with another. Moreover, this network can be extended to a large area in this scope. Also the GPS technique used in this proposed network to determine the position of the wireless device that helps in the emergency situation to know the position of the patient [34].

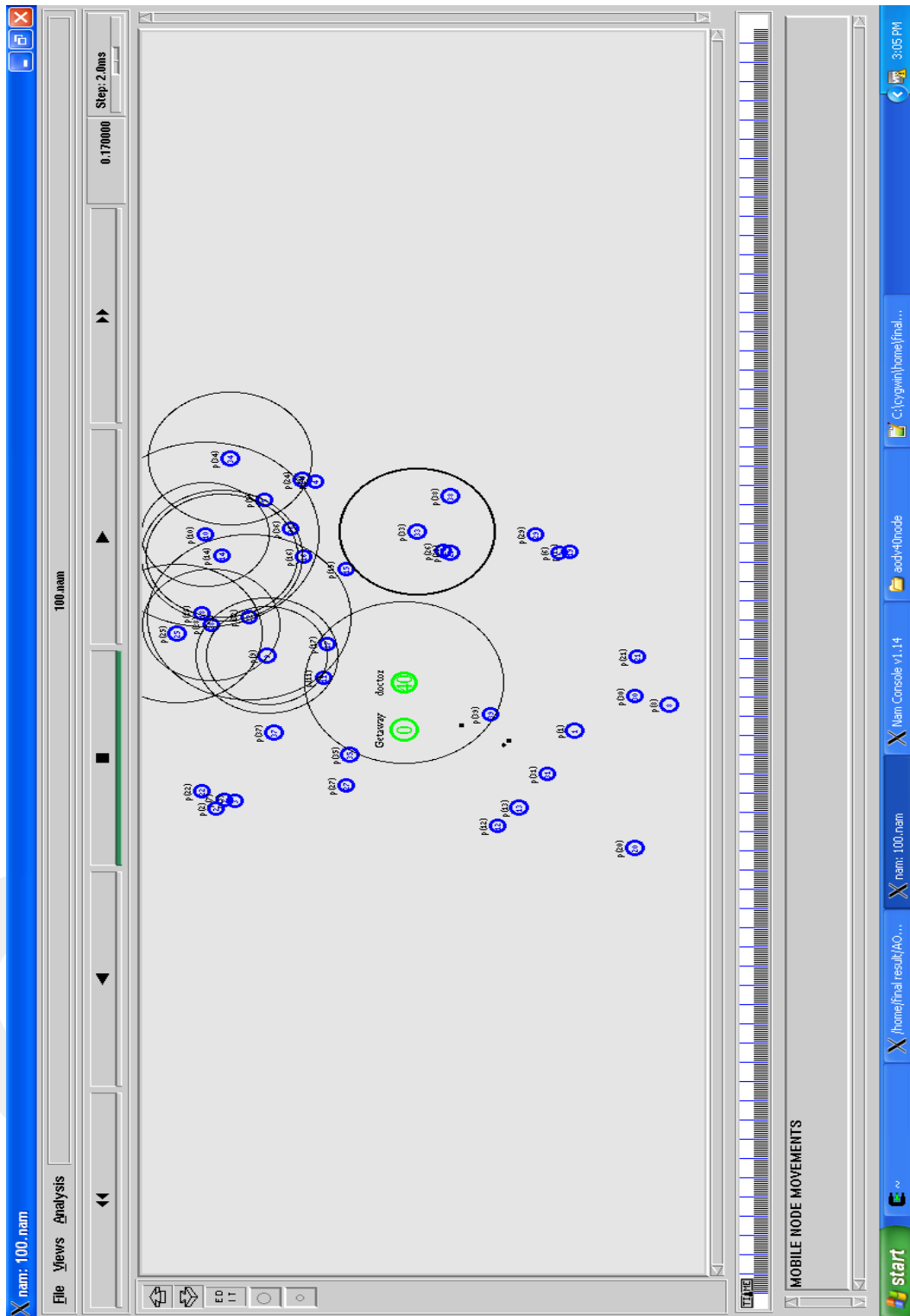

Figure 16: E-Healthcare network with 40 patients

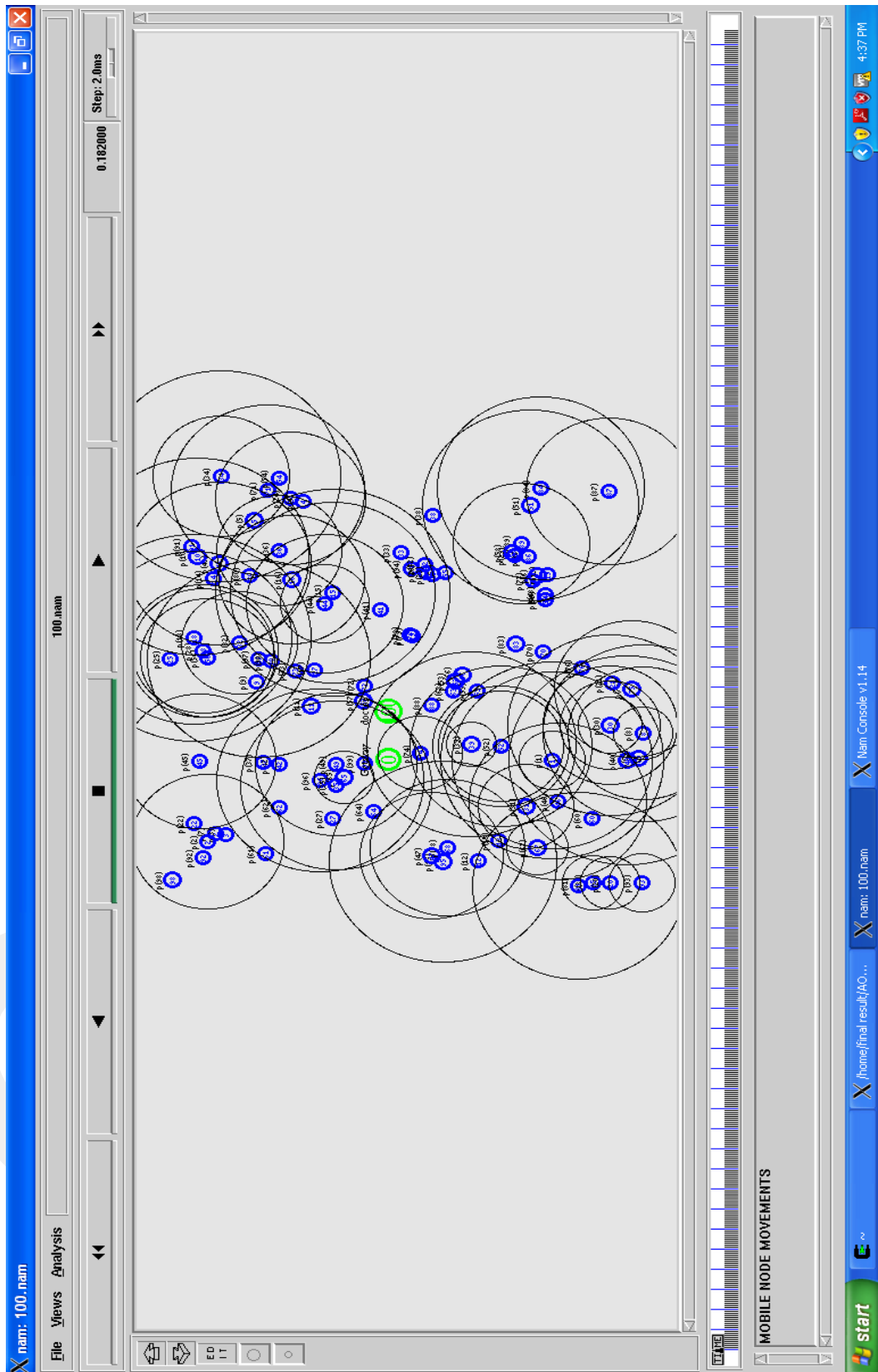

Figure 17: E-Healthcare network with 100 patients

As seen in Figs.(16,17), when the smart device needed to send data from the patient to the doctor, the mobile device uses MANET technology to transfer data firstly to the gateway of the network and then, the gateway will directly send the data to the doctor at other network. As mentioned in chapter 2, MANET represents the collection of the wireless devices that are connected together without any centralized device using multi hop technique in order to transfer the data from source to destination. The most important thing in MANET is selecting the best routing protocol for the network. MANET has many kind of routing protocols as seen in chapter 2, AODV and DSDV are the most important routing protocol for the proposed network.

3.4. Network Parameters

When design any type of network a lot of parameters should be taken in consideration. The parameters of the designed network are illustrated in following table:

Table 2 : Network Parameter

NETWORK PARAMETER	TYPE
Simulator	Ns2.34
Channel type	Channel/Wireless Channel
Simulation area	1000m*1000m
Mac protocol	IEEE802.11
Mobile nodes	20,40,60,80,100,120
Antenna type	Omni Antenna
Propagation model	Two Ray Ground
Routing protocols	AODV,DSDV
Traffic sources	TCP
Packet size	512 Bytes
Simulation time	500 s
Mobility model	Random

The parameters that are selected to configure the proposed network will be described below:

- 1) As mentioned before, NS2 is the best simulator to simulate the proposed network.
- 2) For the type of channel, wireless is selected to support mobility for the patients.
- 3) Simulation area was taken 1000m*1000m because the patients are placed in that fixed area range with one cluster.
- 4) The reason of selecting IEEE802.11 for the mac protocol to support the transmission range for the network. In addition, IEEE802.11 has a lot of advantages such as the resistance for shadowing, refraction and reflection.
- 5) AODV and DSDV are general types of routing protocols as mentioned in chapter 2, and they are tested to select the best one for the proposed network.
- 6) TCP protocol for the traffic source was selected due to the type of data that is sent from the patient to the doctor, is represented as a text data included patient's id and the date of the data with the position of the patient by using GPS technique .

In this research, the comparison between AODV and DSDV is done to select the best one for the proposed network based on four metrics PDR, End to End delay, throughput and drop packet.

3.5. Metrics Calculations

Four performance metrics were selected to compare the two routing protocols AODV and DSDV:-

1. Average End-to-End Delay

It is average of time taken by the data packets that propagate from source to destination through a MANET. This includes all possible delays caused by buffering during routing discovery latency, queuing at the interface queue, and retransmission delays at the MAC, propagation and transfer times.

Average End-to-End Delay = $\frac{\text{Sum (for each } i \text{ equal to packet number, (packet received time- packet sent time))}}{\text{packet number}}$ (3.1)

NOTE: The lower value of the end -to-end delay means better performance for the protocol.

2. Packet Delivery Ratio (PDR)

It is a ratio of the number of data packets successfully delivered from the destinations to those generated by sources.

$$\text{PDR} = \text{received packets/sent packets} * 100 \quad (3.2)$$

NOTE: The higher value of the PDR leads to better protocol performance.

3. Packet Loss

It is the total number of packets dropped by nodes due to various reasons [9].

$$\text{Packet lost} = \text{No.of packet send} - \text{No .of packet received.} \quad (3.3)$$

NOTE: The lower value of the packet lost for better performance of the protocol.

4. Throughput

It is the rate of successfully transmitted data packets in a unit time in the network during the simulation.

$$\text{Throughput} = \text{Total received packet} / \text{Elapsed time between sent and receive} \quad (3.4)$$

NOTE: Higher value of the throughput for better performance of the protocol.

3.6. Parameters Computation

As seen above, NS2 uses two languages Otcl and C++. TCL code is used to program the proposed network. After running TCL code, two main files will be created, the first one called NUM file which is used to display the graphic of the proposed network, the second one called trace file which is used to analyze the features of the network.

```

1 v 0 eval {set sim_annotation {MOBILE NODE MOVEMENTS}}
2 M 0.10000 1 (307.32, 190.11, 0.00), (639.91, 916.75), 8.60
3 M 0.10000 2 (113.64, 912.66, 0.00), (296.89, 847.31), 6.97
4 M 0.10000 3 (131.43, 875.82, 0.00), (935.65, 417.55), 7.48
5 M 0.10000 4 (923.47, 712.85, 0.00), (322.26, 191.50), 4.81
6 M 0.10000 5 (878.37, 815.36, 0.00), (812.87, 964.32), 4.09
7 M 0.10000 6 (747.74, 221.11, 0.00), (195.28, 31.31), 1.77
8 M 0.10000 7 (133.81, 896.97, 0.00), (915.97, 743.83), 5.39
9 M 0.10000 8 (371.51, 0.98, 0.00), (820.58, 436.72), 9.29
10 M 0.10000 9 (493.83, 810.84, 0.00), (89.67, 111.43), 7.97
11 M 0.10000 10 (792.76, 934.87, 0.00), (193.40, 440.24), 0.79
12 M 0.10000 11 (437.06, 697.45, 0.00), (833.38, 614.17), 3.80
13 M 0.10000 12 (70.29, 345.99, 0.00), (35.60, 266.77), 6.09
14 M 0.10000 13 (117.11, 302.72, 0.00), (261.18, 649.20), 1.13
15 M 0.10000 14 (739.75, 902.23, 0.00), (682.29, 299.34), 0.66
16 M 0.10000 15 (707.01, 651.20, 0.00), (424.68, 551.08), 9.32
17 M 0.10000 16 (738.55, 736.75, 0.00), (376.24, 443.24), 5.19
18 M 0.10000 17 (521.31, 688.80, 0.00), (882.65, 776.71), 1.95
19 M 0.10000 18 (598.08, 943.46, 0.00), (145.25, 261.31), 7.98
20 M 0.10000 19 (749.10, 201.35, 0.00), (970.82, 545.03), 2.72
21 s 0.100000000 _1_ AGT --- 0 tcp 40 [0 0 0 0] ----- [1:0 0:0 32 0] [0 0]
22 r 0.100000000 _1_ RTR --- 0 tcp 40 [0 0 0 0] ----- [1:0 0:0 32 0] [0 0]
23 s 0.100000000 _2_ AGT --- 1 tcp 40 [0 0 0 0] ----- [2:0 0:1 32 0] [0 0]
24 r 0.100000000 _2_ RTR --- 1 tcp 40 [0 0 0 0] ----- [2:0 0:1 32 0] [0 0]
25 s 0.100000000 _3_ AGT --- 2 tcp 40 [0 0 0 0] ----- [3:0 0:2 32 0] [0 0]
26 r 0.100000000 _3_ RTR --- 2 tcp 40 [0 0 0 0] ----- [3:0 0:2 32 0] [0 0]
27 s 0.100000000 _4_ AGT --- 3 tcp 40 [0 0 0 0] ----- [4:0 0:3 32 0] [0 0]
28 r 0.100000000 _4_ RTR --- 3 tcp 40 [0 0 0 0] ----- [4:0 0:3 32 0] [0 0]
29 s 0.100000000 _5_ AGT --- 4 tcp 40 [0 0 0 0] ----- [5:0 0:4 32 0] [0 0]
30 r 0.100000000 _5_ RTR --- 4 tcp 40 [0 0 0 0] ----- [5:0 0:4 32 0] [0 0]

```

Figure 18: Trace file

Table 3: Trace File Format

Event	Time	From node	To node	Pkt. type	Pkt. size	Flags	Fid	Src. addr.	Dst. addr.	Seq. num.	Pkt. id
-------	------	-----------	---------	-----------	-----------	-------	-----	------------	------------	-----------	---------

As seen in Fig .10 and Table .3, 12 fields of the trace string are as follows:

1. Type event:

- “r”: a packet reception event
- “d”: a packet drop (e.g., sent to drop Head) event
- “c”: a packet collision at the MAC level

2. Time: time for creating the packet tracing string .

3. From node.

4. To node.

The two fields (3, 4) denote the IDs of the source and the destination nodes of the tracing object.

5. Packet type: packet type name.
6. Packet size: packet size in bytes.
7. Flags: A 7-digit flag string
 - “**I**”: disable
 - 1st = “**E**”: ECN (Explicit Congestion Notification) echo is enabled.
 - 2nd = “**P**”: the priority in the IP header is enabled.
 - 3rd : Not in use
 - 4th = “**A**”: Congestion action
 - 5th = “**E**”: Congestion has occurred.
 - 6th = “**F**”: The TCP fast start is used.
 - 7th = “**N**”: Explicit Congestion Notification (ECN) is on.
8. FID: means flow ID.
9. Source Address.
10. Destination Address.

The format of the two fields (9, 10) is “**a.b**”, where “**a**” is the address and “**b**” is the port.

11. Sequence Number.
12. Packet Unique ID

In this research, awk tool used to process the trace file. The awk tool allows to perform simple operations on trace files such as averaging the values of a given column, summing or multiplying terms between several columns, all data- formatting tasks, etc.

After creating the trace file, awk tool should be put at the same path for the trace file, for example writing the following short script to get the result of the parameters:

awk -f throughput.awk final-network.tr > outfile

The trace file here is **final-network.tr**, the output file for the parameter which will be determined, is **outfile** and the awk tool that is used to analyze the trace file is **throughput.awk**.

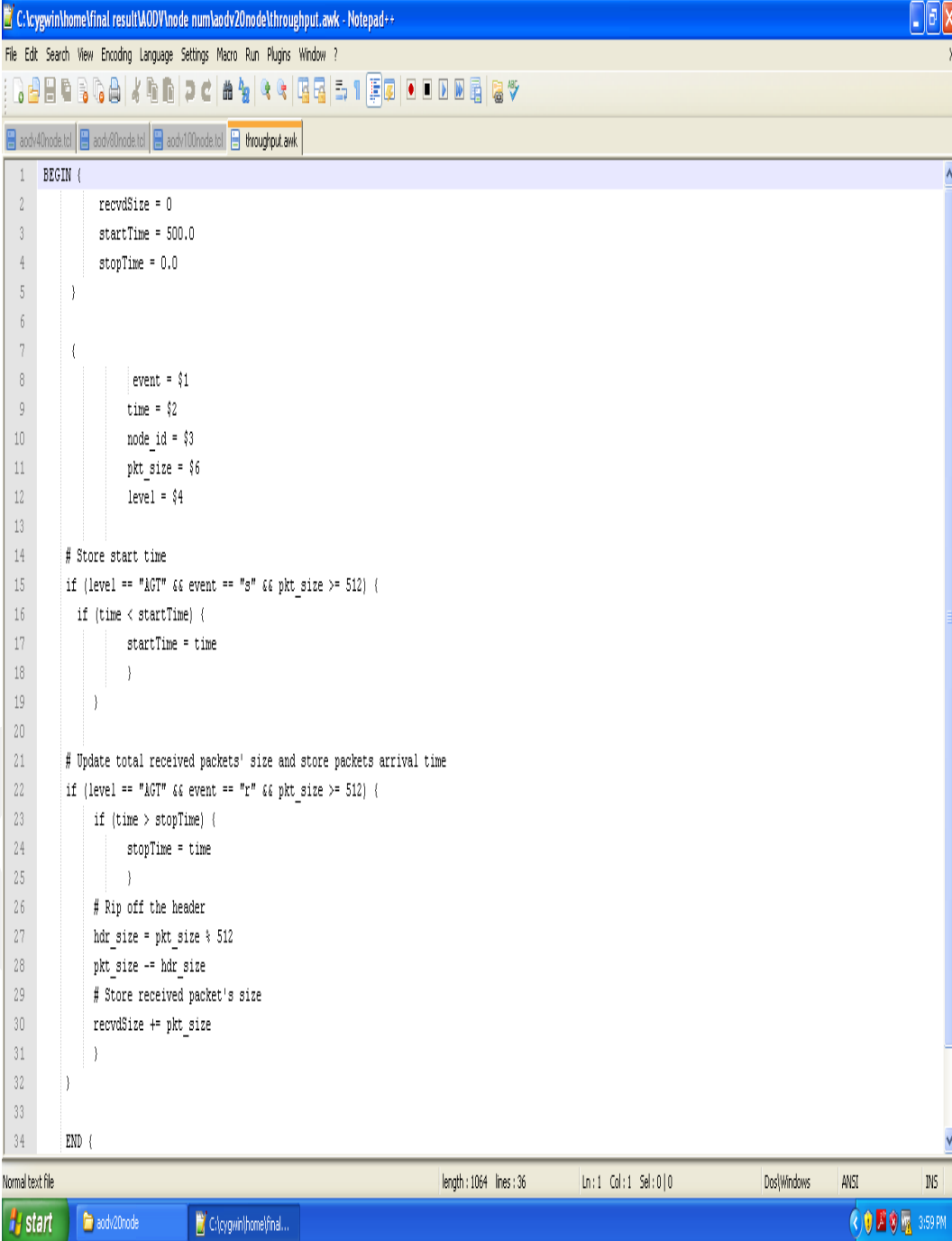

```
1 BEGIN {
2     recvdSize = 0
3     startTime = 500.0
4     stopTime = 0.0
5 }
6
7 {
8     event = $1
9     time = $2
10    node_id = $3
11    pkt_size = $6
12    level = $4
13
14    # Store start time
15    if (level == "AGT" && event == "a" && pkt_size >= 512) {
16        if (time < startTime) {
17            startTime = time
18        }
19    }
20
21    # Update total received packets' size and store packets arrival time
22    if (level == "AGT" && event == "r" && pkt_size >= 512) {
23        if (time > stopTime) {
24            stopTime = time
25        }
26
27        # Rip off the header
28        hdr_size = pkt_size % 512
29        pkt_size -= hdr_size
30        # Store received packet's size
31        recvdSize += pkt_size
32    }
33
34    END {
```

Figure 19: Throughput TCL code

```

C:\cygwin\home\final result\AODV\mode num\ao dv20\mode\ZeDelay.awk - Notepad++
File Edit Search View Encoding Language Settings Macro Run Plugins Window ?
e2edelay.awk
25     start_time[$6] = $2;
26     } else if(($7 == "tcp" && ($1 == "r")) {
27         end_time[$6] = $2;
28     } else if($1 == "D" && $7 == "tcp") {
29         end_time[$6] = -1;
30     }
31 }
32 END {
33
34     for(i=0; i<=seqno; i++) {
35         if(end_time[i] > 0) {
36             delay[i] = end_time[i] - start_time[i];
37             count++;
38         }
39         else
40         (
41             delay[i] = -1;
42         )
43     }
44     for(i=0; i<=seqno; i++) {
45         if(delay[i] > 0) {
46             n_to_n_delay = n_to_n_delay + delay[i];
47         }
48     }
49     n_to_n_delay = n_to_n_delay/count;
50     print "\n";
51     print "GeneratedPackets      = " seqno+1;
52     print "ReceivedPackets          = " receivedPackets;
53     print "Packet Delivery Ratio    = " receivedPackets/(seqno+1)*100
54 "%";
55     print "Total Dropped Packets = " droppedPackets;
56     print "Average End-to-End Delay  = " n_to_n_delay * 1000 " ms";
57     print "\n";
58 }

```

Figure 20: PDR, E2Edelay, drop packet TCL code

Figs.(19, 20) represents the codes that are written using TCL and C++ programs in order to determine the introduced parameters (PDR, End to End delay, throughput and drop packet).

3.7. Simulation Result

In this section the comparison between two routing protocols for MANET technology in DSS field AODV and DSDV for the E-healthcare network is done to test which one is suitable and better to support the network.

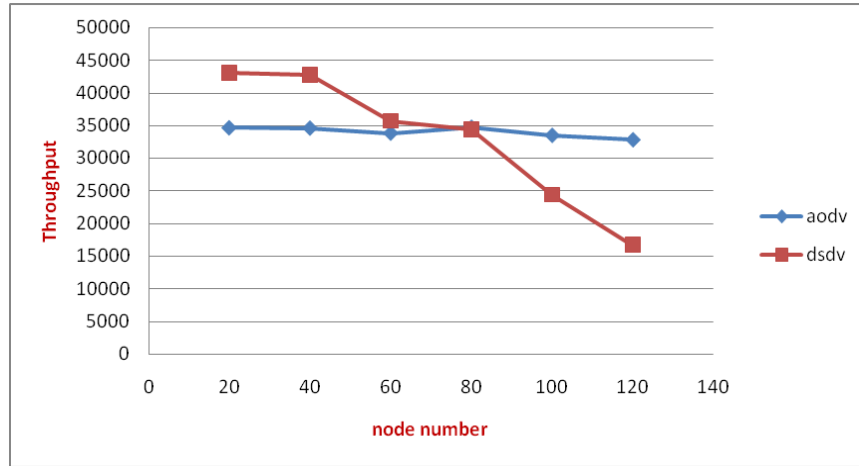

Figure 21: Throughput Vs. varying number of nodes

In the throughput case, it was noticed that the AODV routing protocol keeps the throughput at the same range with increasing the number of nodes, whereas the DSDV routing protocol far decrease with increasing the number of nodes. Therefore, the performance of the AODV is better than the DSDV. This is seen in Fig.21.

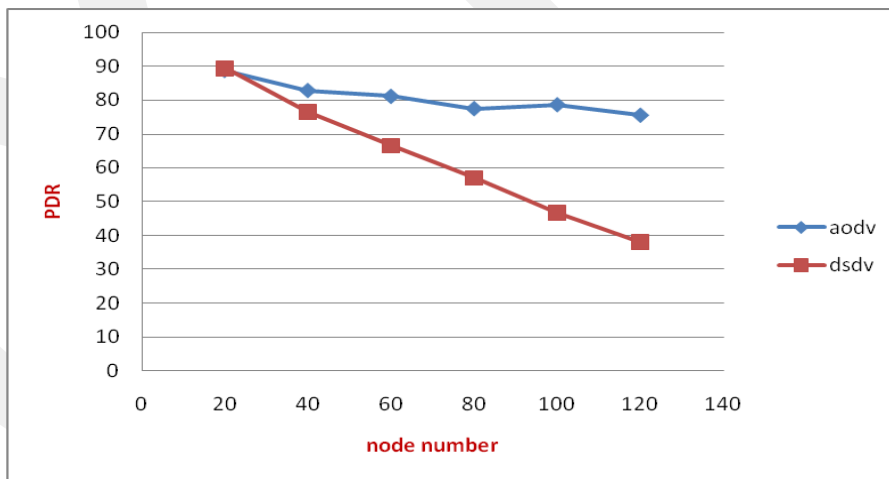

Figure 22: PDR Vs. varying number of nodes

Fig.22 shows the case of PDR. It is clear that the AODV routing protocol slightly decreases with increasing the number of nodes, whereas the DSDV routing protocol

far decreases with increasing the number of nodes. Therefore, the performance of the AODV in this case is better than the DSDV.

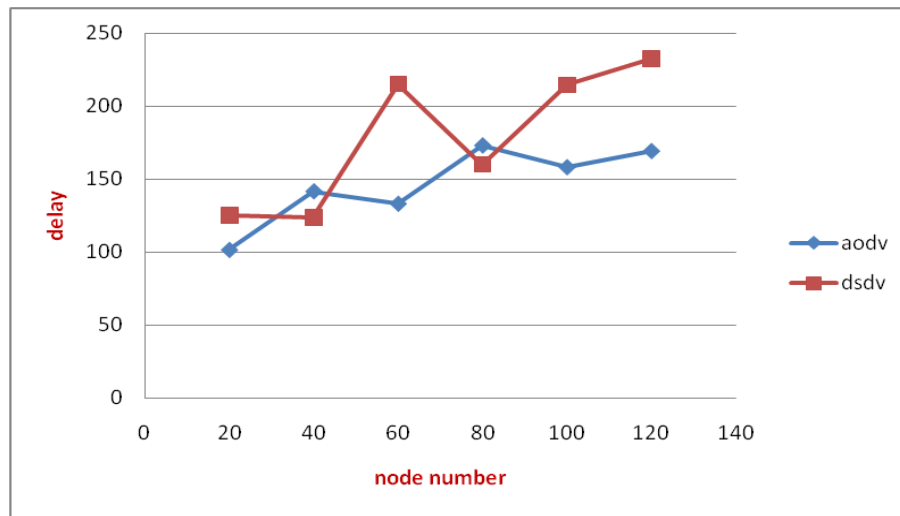

Figure 23: End-To-End delay Vs. varying number of nodes

The case of end to end delay as shown in Fig.23, the AODV routing protocol slightly increases in the e2e delay with increasing in the number of nodes, whereas the DSDV routing protocol far increase in the e2e delay with increasing the number of nodes. Therefore, the performance of the AODV in this case is better than in the DSDV.

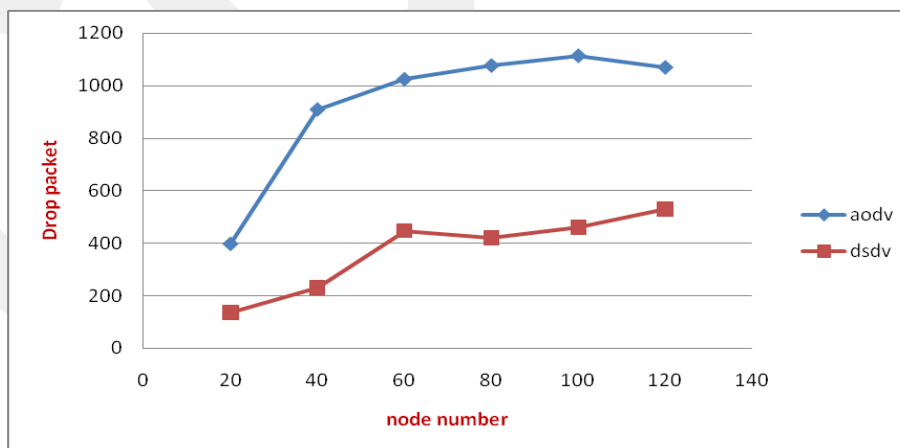

Figure 24: Drop packets Vs. varying number of nodes

In case of drop packets in Fig.24, it is obvious that the AODV routing protocol drop packet far increase with increasing the number of nodes, whereas the DSDV routing

protocol few increase with increasing in the number of nodes. Therefore, the performance of the DSDV is better than the AODV.

From all previous results, we conclude that the performance of DSDV is better than AODV in the drop packets. Whereas, AODV routing protocol is better than DSDV in the cases of throughput, PDR and End to End delay, when we increase the number of nodes in our proposed network, we note that AODV routing protocol keep their stability but the DSDV routing protocol go down. Therefore, the suitable routing protocol that makes the proposed network for the E-healthcare system works well is AODV routing protocol.

CHAPTER 4

SYSTEM DESIGN

4.1. Introduction

In this chapter we will describe the proposed E-healthcare system and explain all requirements (hardware and software) that took in consideration to design the proposed system. The system that is proposed in this work generally divided into three tiers patient, medical server and healthcare provider. All these tier are designed and programming in this section used high level language C#. Moreover, the rule of the decision maker in the medical server is chooses to support the system. In addition, the main issue of designed any E-healthcare system, website is designed and programming in this section used ASP.net.

4.2. Proposed System

In Fig.25 below, over view of our proposed system for the E-healthcare system is presented. As mentioned in chapter 2, any E-Healthcare system included three main parts as our proposed system that be divided into three main tiers.

- 1- The first tier is related to the patient. This tier is represented as a data which will be read by the smart device (mobile or PDA) then the smart device sends the data to the medical server to be analyzed.
- 2- The second tier responsible of the medical server included the decision maker to analyze the data that is coming from the patient, also the database used for the proposed system.
- 3- Last but not least, the third tier deals with the healthcare provider completely.

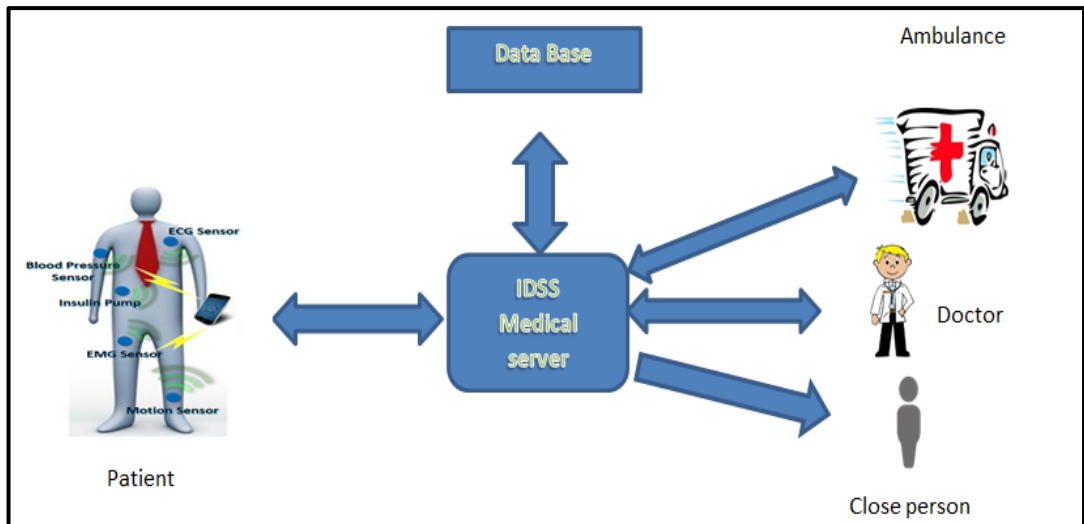

Figure 25: Over view of the proposed system

Moreover, the website for the proposed system is too important thing in order to communicate the tools among the tiers that were mentioned before.

4.3. System Requirements

The next step in designing such systems is constructing the hardware and the software requirement. This is in use now because a typical system is designed such that the resources implementation fulfills system requirements.

4.3.1. Hardware Requirements

The server we used in this thesis is based on this PC such that the components of the system can be connected together and can reach the database using the server. In addition, the website of our proposed system is hosted on this server.

4.3.2. Software Requirements

➤ Operating system

Operating such a system is come true by choosing windows 7 as our operating system.

➤ server and database software

SQL server management R2 2008 is used to implement server and database. The reason to use SQL server due to the Microsoft open source propriety, widely use, and it is easy to setup and usage. SQL server management is available at [35].

➤ **Website software**

In order to design the website we need pages such that are dynamically generated, **ASP.net** with visual basic language is the best select to program the website. **ASP.net** has a lot of advantages to so that it deserves to get the first places in the international classification. The open source is one of these advantages. Moreover, the accuracy that is provided by the **ASP.net** recommends this program to be the best selecting in order to use it in the smart devices. Our proposed system requires reaching to the website by the smart devices that are used through the healthcare providers and other members.

➤ **End user interface**

C# language is the best select to program this item, and the rules that are used to analyze the data are coming from the patient. Also the communication between end user and the server was established by using **C#** language. **C#** language is selected because of, it is high level language of **C++** and it is open source. **C#** and **ASP.net** are free sources extracted from Microsoft; they are founded in visual studio and available at [36].

4.4. Patient Tier Design

As mentioned in chapter 2, the patient side has various types of sensors attached on the body of the patient, these sensors work to capture the vital data from the body then send it to the smart device using whether wired or wireless connection like Bluetooth or Zigbee. Next, the smart device works to send these data to the medical server for analyzing issues.

The proposed work in this section concentrates on reading the data form patient mobile and uploading it to the medical server. Patient tier is designed using **C#** program. The program designed to read the data from log text file in the same pc that works as server.

As mentioned in chapter (1, 2), there are many types of chronic diseases that the researchers focus on. The increasing in heart disease infections in the world put this kind of disease in the first place of chronic disease that should be taken in consideration. Therefore, the recent researches focus on the suggestion and the design of E-Health monitoring system which helps to decrease the load on the

Fig.27 below shows the form design of the patient mobile that includes the following:

- 1- Patient ID.
- 2- The Date and the time for the data that will be sent.
- 3- The Position of the patient that will be used in the emergency situations. This position is provided by using GPS technique in the proposed network as seen in chapter3.
- 4- Finally, the heartbeat and the blood pressure that are captured by the sensors node.

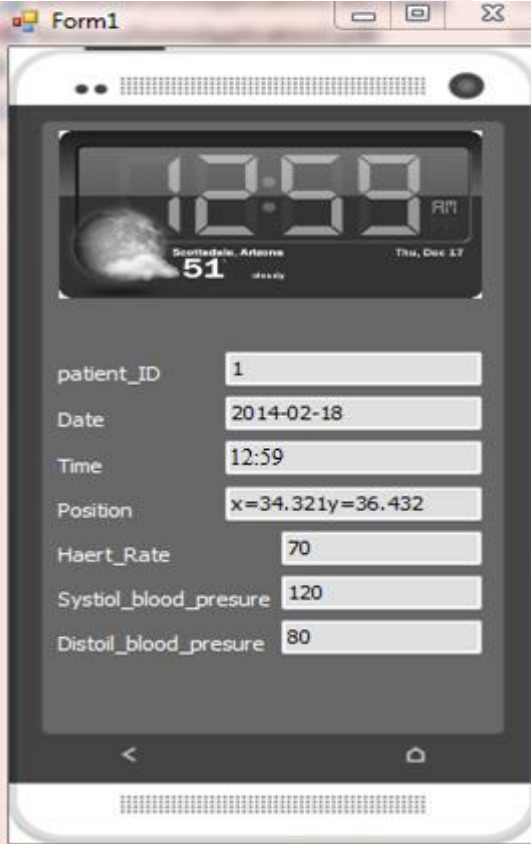

The image shows a screenshot of a mobile application window titled "Form1". The window displays a digital clock showing 12:59 AM, the location "Scottsdale, Arizona", and the date "Thu, Dec 17". Below the clock, there are several input fields for patient data:

Field Name	Value
patient_ID	1
Date	2014-02-18
Time	12:59
Position	x=34.321y=36.432
Haert_Rate	70
Systol_blood_presure	120
Distoil_blood_presure	80

Figure 27: Mobile patient

When the data is read from patient program, it will be sent to the server. The server will analyze these data as description in the next section.

4.5. Medical Server Tier Design

The medical server such as the heart of the proposed system makes all system components to be in touch and provides access to the database of the system.

Besides, the server is responsible of the rules for the DS that works to analyze the data and help the healthcare provider to get the best and the faster decision. In other hand, the tasks that be performed through the server are listed below:

1- Access to the database

Server should be able to interact with the database for the system that depends on the request received from the system components.

2- Communication between patient mobile and database

In this order, the server allows the patient mobile to insert data to the database for the system; this data is saved in the database and will be used by other components.

3- Perform DS

The server is responsible of the rules used to analyze the vital data comes from the patient and give the best solution that helps both patients and doctors, which will be described later.

4- Hosted website

The website is hosted in the server which is used in the proposed system. In addition, the server allows the users of the system to be directly interacted with the database though the website with different levels.

4.5.1. Database Design

The database in our proposed system is used to store and retrieve the data. This database consists of some information sorted in a specific collection used by the applications of the system. This information is related to the patients that are registered in the system, also some information for the doctor, nurses, and the administrations of the system.

Some issues are taken into consideration when we designed the database security and authentication, these issues are provided by using SQL server management R2 2008 as we mentioned before. The database has number of tables, all these tables describes below.

Table 3: Database Entities

Table name	Description
Patient information	Includes patient [ID, Name, Age, Gender, Address, Phone Number, Email, Doctor Name, Type Of Disease, The Status Case Of Patient Disease ...etc.]
Staff information	Includes Staff [ID, Name, Position, Email, Phone, specialize...etc.]
Monitoring data	Contains the monitor data that is coming from the patients
Queue data	The data that helps for scheduling the mining of other data that is used in the server
Contact us data	Contains [Name, Email, Department, Type Of Question and Description], this information comes from the Website →Contact us page.

4.5.2. Decision Making Implementation

Decision maker is a set of rules that be used to support our E-healthcare system. In this thesis, data mining technique is used to get the data that are stored in the database of the patient, these data is represented as a range limited by the doctor.

When a patient got health problem, absolutely, a doctor specializes in that problem should be seen. The doctor diagnoses the problem of the patient to find out the problem that caused the disease. Normally, the doctor controls patient disease after sometimes, hereby the patient will be registered in the e-healthcare system to get real health monitoring and better life. The registration issues will be done by the doctor, in order to count the cases that the patient suffers. Finally, patient cases are kept in the database. Generally, these cases are classified into three parts:

- Normal case.
- Abnormal case.
- Emergency case.

The rules of decision maker in the medical sever is interacted with these data ranges above to make a compression with the data received from patient mobile to find out patient situation, this process is described in the following Fig.28.

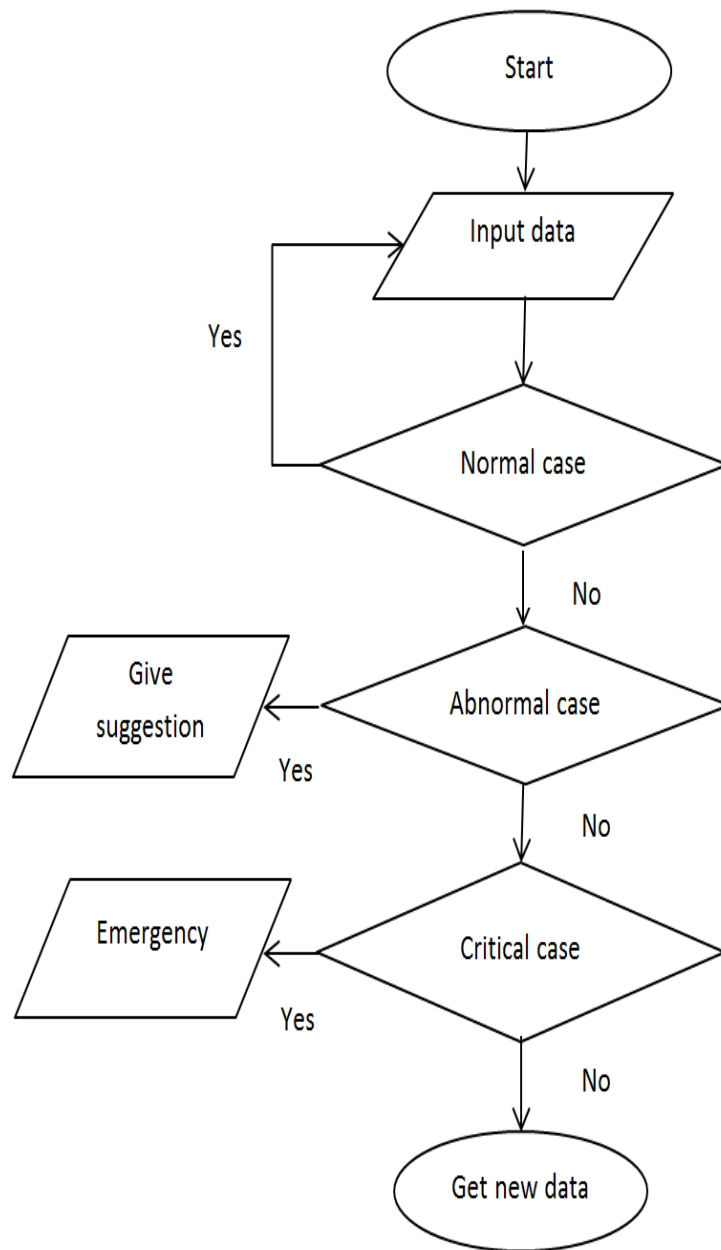

Figure 28: Activity block diagram for the proposed system

Our system works to provide better and easier life for the patients that they have heart disease. In order to monitor these kinds of patients, the heartbeat and blood pressure should be monitored continuously, as we mentioned before, the data is sent from patient mobile then will be analyzed by the server. The algorithm that is used to analyze the data based on some issues that are described as follows:

The normal range of heartbeat for adults, including elderly and every one over 10 years, is between 60 and 100 heartbeats a minute.

- For Neonates ranging from 70-190.

- For baby between 1 and 11 months 80-160.
- For one up to two years old 80-130.
- For three up to four years old 80-120.
- Between five and six years old 75-115.
- Between seven and nine years old 70-110.
- For ten and over years old 60-100.

Normal heartbeats affected by health changes, where these changes are responses to some conditions, which are composed of exercise, body temperature, body position (such as for a short while after standing up quickly), and emotion (such as anxiety and arousal).

- Tachycardia means the heart is beating too fast at rest (usually over 100 beats a minute).
- Bradycardia is a heart rate that is too slow (usually below 60 beats a minute) [37].

The values which gave are typical, but if are above or below the range may be normal and harmless for some. The introduced algorithm is used to analyze the data that depends on the values that the doctor puts in the database.

In order to make these issues of the heart rate more clear, we take an example for one patient is registered in our proposed system and a doctor who inserts the heartbeat range of that patient for normal, abnormal(tachycardia and bradycardia) and critical cases.

- ❖ Name: Gali kamel.
- ❖ Gender: male.
- ❖ Age: 60.
- ❖ Normal heartbeat: 60-95.
- ❖ Abnormal1 tachycardia: 95-110.
- ❖ Abnormal2 tachycardia: 110-120.
- ❖ Abnormal bradycardia: 50-60.
- ❖ Critical tachycardia: over 120.
- ❖ Critical bradycardia: under 50.

For this patient, the server works to compare the data coming from patient mobile with these data above. As we mentioned above, the normal heartbeat for this patient is limited from 60 to 95, if the data comes at this range, the server just works to keep this data in the database of this patient. Abnormal tachycardia has two parts, the first part is ranged from 95 to 110 which happens in case of an effort is done by the patient such as sport exercises practicing or entering in a bad situation such as getting angry. These situations effect on heartbeat not heavily such that the heart can return back to its normal behavior according to the range mentioned above. Hereby, the medical server waits 30 minutes and then will send an alarm message to the patient and the doctor. The second part of tachycardia is ranged from 110 to 120 and the case of (bradycardia) is ranged from 50 to 60 that affect directly on the patient. Therefore, the server will send an alarm to the doctor in order to diagnose and treat the patient directly; also an additional alarm will be sent to the close person of the patient. Last but not least, the critical case of the patient is ranged over 120 or fewer than 50, in this situation a number of alarms will be sent directly to the emergency department to hurry up and help depending on the position data that is coming from the mobile using GPS technique. In accordance, the doctor and the close person will receive an alarm.

All these issues are described in Fig.29.

- Z means the heart rate comes from patient mobile per minute.
- The normal case (NC) is start form x_{nc} to y_{nc} .
- The abnormal1 tachycardia (ua1) starts form x_{ua1} to y_{ua1} .
- The abnormal bradycardia (la) starts form x_{la} to y_{la} .
- The abnormal2 tachycardia (ua2) starts form x_{ub2} to y_{ub2} .
- The critical tachycardia is (x_e).
- The critical bradycardia is (y_e).

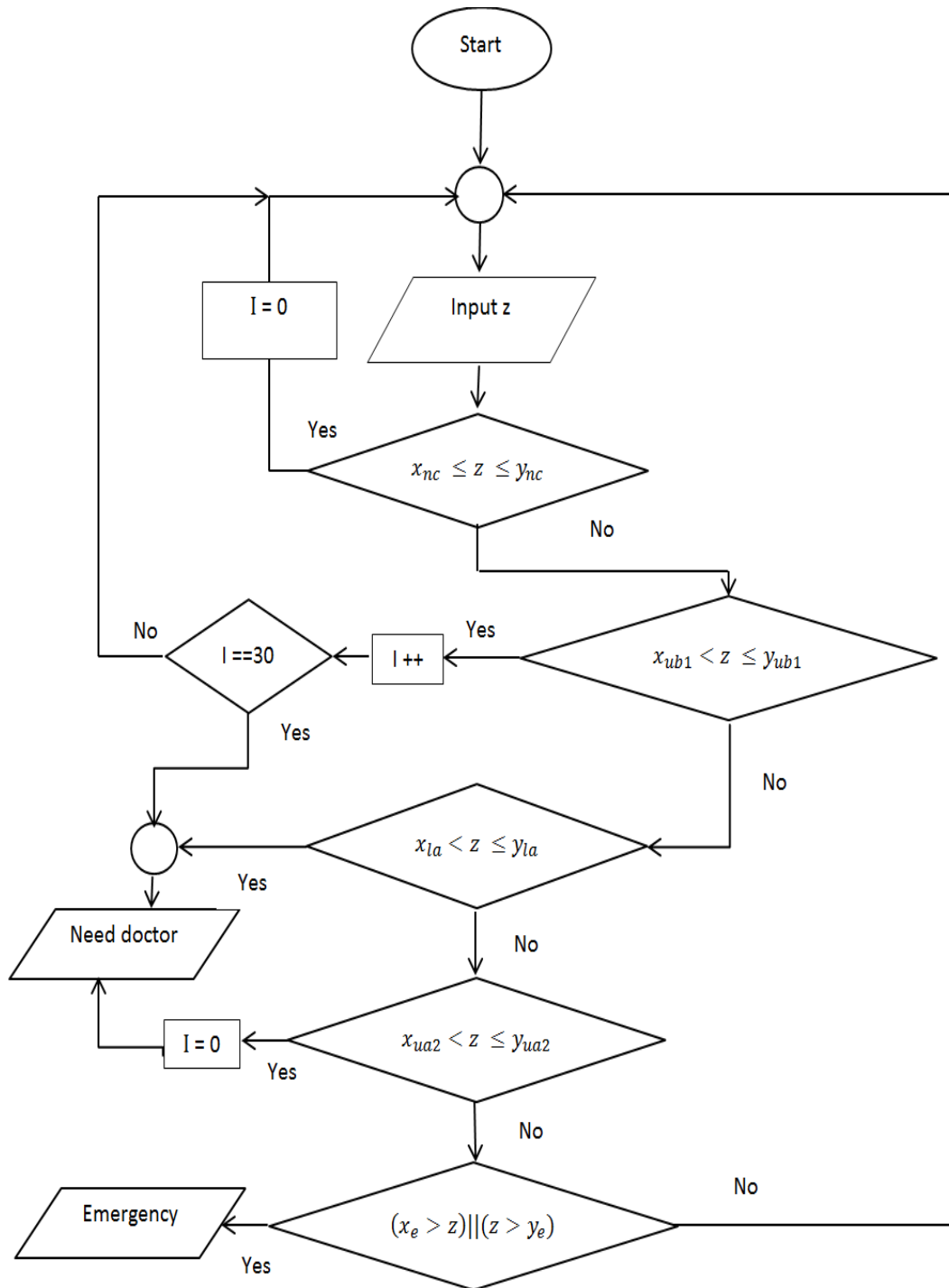

Figure 29: Heartbeat analysis block diagram

The second issue that will be monitored next is the blood pressure. Blood pressure issue is divided into three cases, normal, abnormal and critical. Generally, blood pressure issue has two levels, high level denoted as systole and low level denoted as diastole. The normal range of the human blood pressure is about 120 systole and 80 diastole, less or more than the range we specified, the human case will be considered

as abnormal or critical. Data of the blood pressure that are inserted by the doctor to the database of the same patient above, illustrated below. these data are used to compare with data coming from the patient mobile into medical server in order to decide case of the patient if there is an alarms should be sent or not. The difference between heartbeat and blood pressure is the first one sends every minute but the second is sent each 4 hours as needed.

- ❖ Normal systole: 100-140.
- ❖ Normal diastole: 70-90.
- ❖ Abnormal upper systole: 140-170.
- ❖ Abnormal upper diastole: 90-100.
- ❖ Abnormal lower systole: 80-100.
- ❖ Abnormal lower diastole: 60-70.
- ❖ Critical systole: over 170.
- ❖ Critical systole: under 80.
- ❖ Critical diastole: over 100.
- ❖ Critical diastole: under 60.

The following block diagram in Fig.30 illustrates blood pressure diagnosis using suitable DS.

- Zs means the systole blood pressure; Zd means the diastole blood pressure that is come from patient mobile each 4 hours.
- The normal systole blood pressure (NS) starts form x_{ns} to y_{ns} .
- The normal diastole blood pressure (ND) starts form x_{nd} to y_{nd} .
- The abnormal systole blood pressure in the upper case (SUA) starts form x_{sua} to y_{sua} .
- The abnormal systole blood pressure in the lower case (SLA) starts form x_{sla} to y_{sla} .
- The abnormal diastole blood pressure in the upper case (DUA) starts form x_{dua} to y_{dua} .
- The abnormal diastole blood pressure in the lower case (DLA) starts form x_{dla} to y_{dla} .
- The critical systole is $(x_{se}), (y_{se})$.
- The critical diastole is $(x_{de}), (y_{de})$.

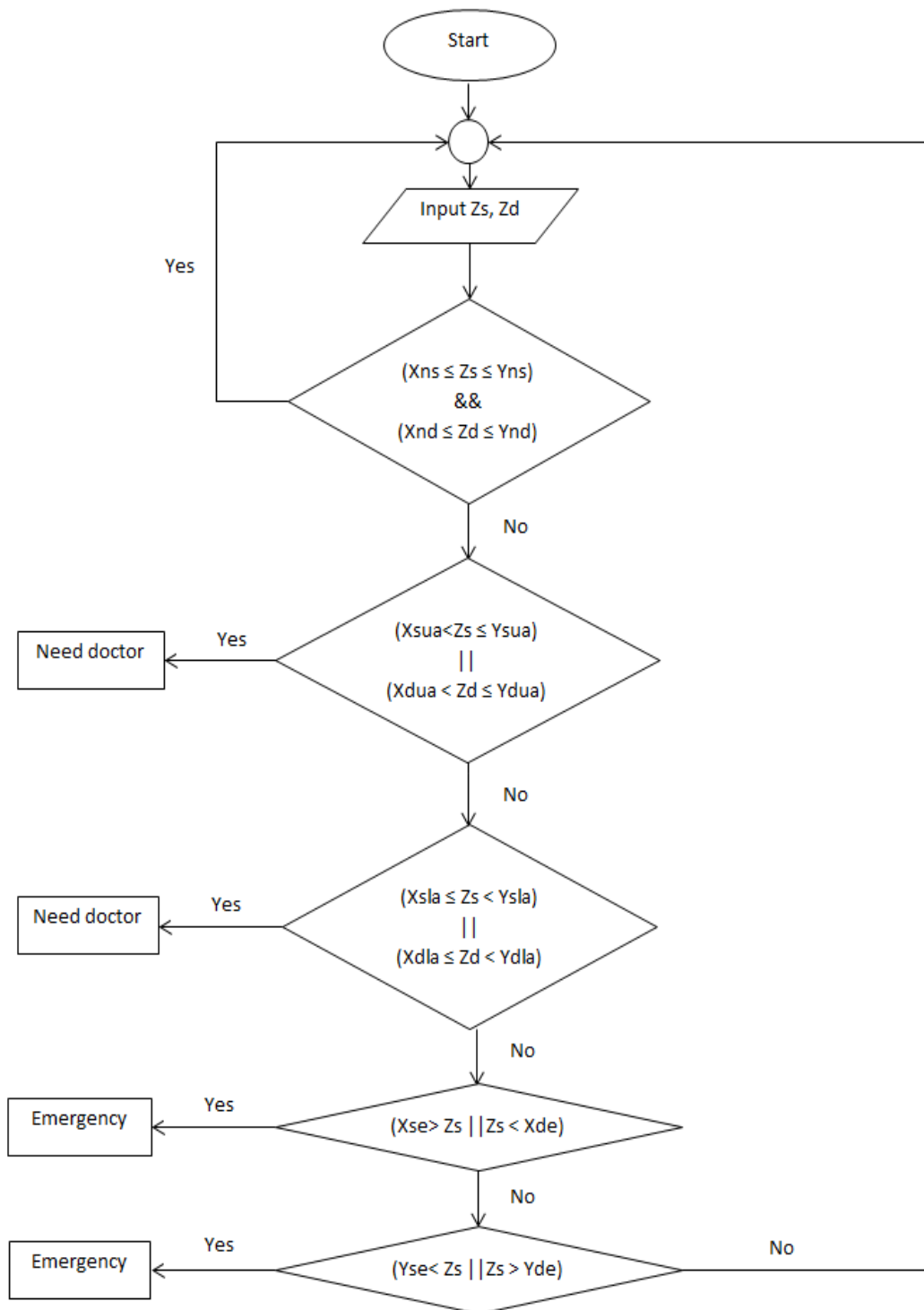

Figure 30: Blood pressure analysis block diagram

C# program is used to control server operations in order to analyze patient mobile data using the algorithms we presented above to take the decision. As shown in the following figures, the alarms that are sent to the doctor, patient, close person and emergency alarm are described.

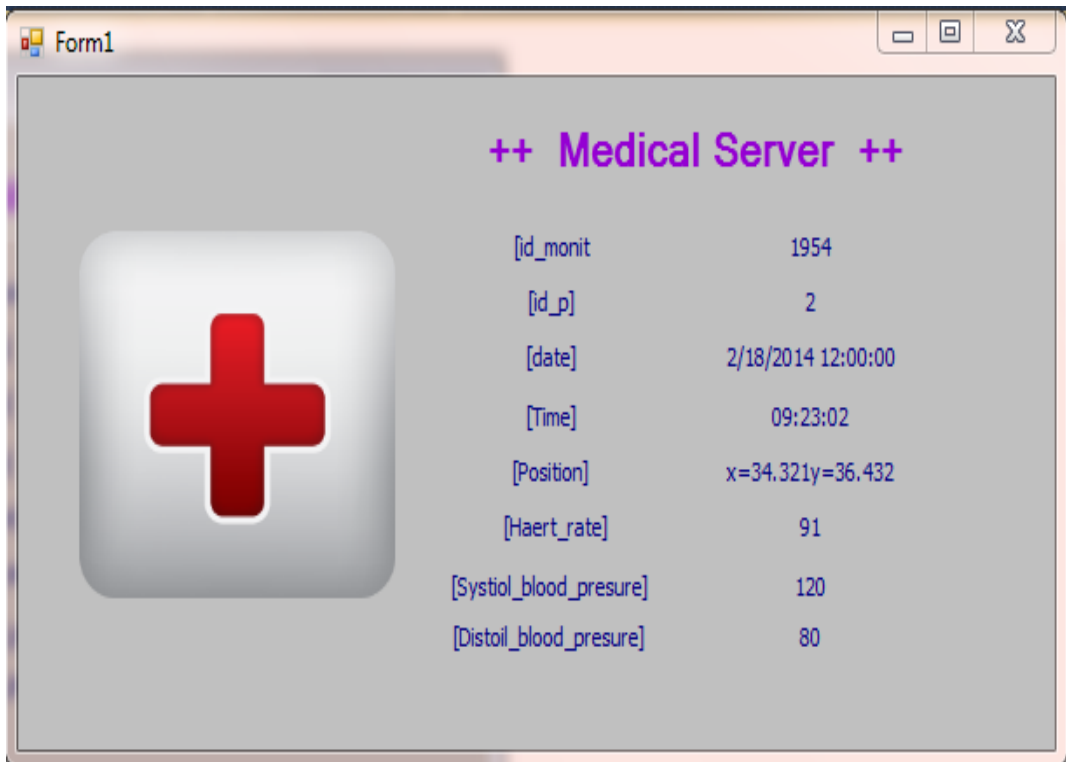

Figure 31: The proposed medical server

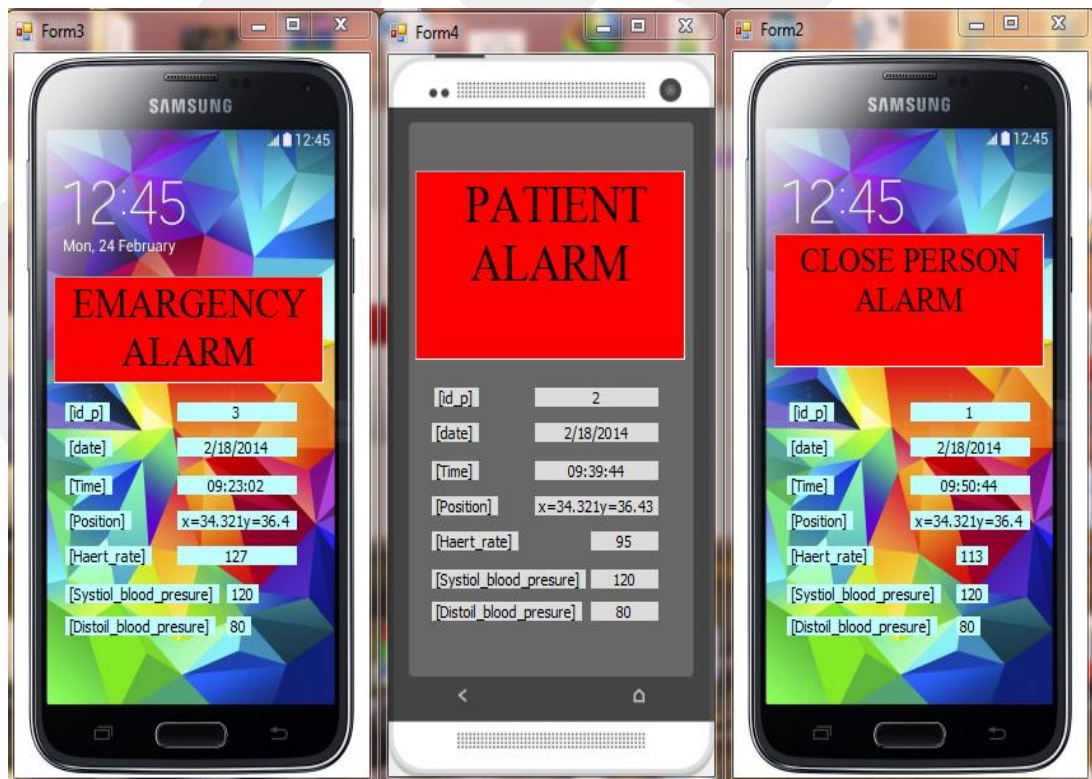

Figure 32: Alarm types

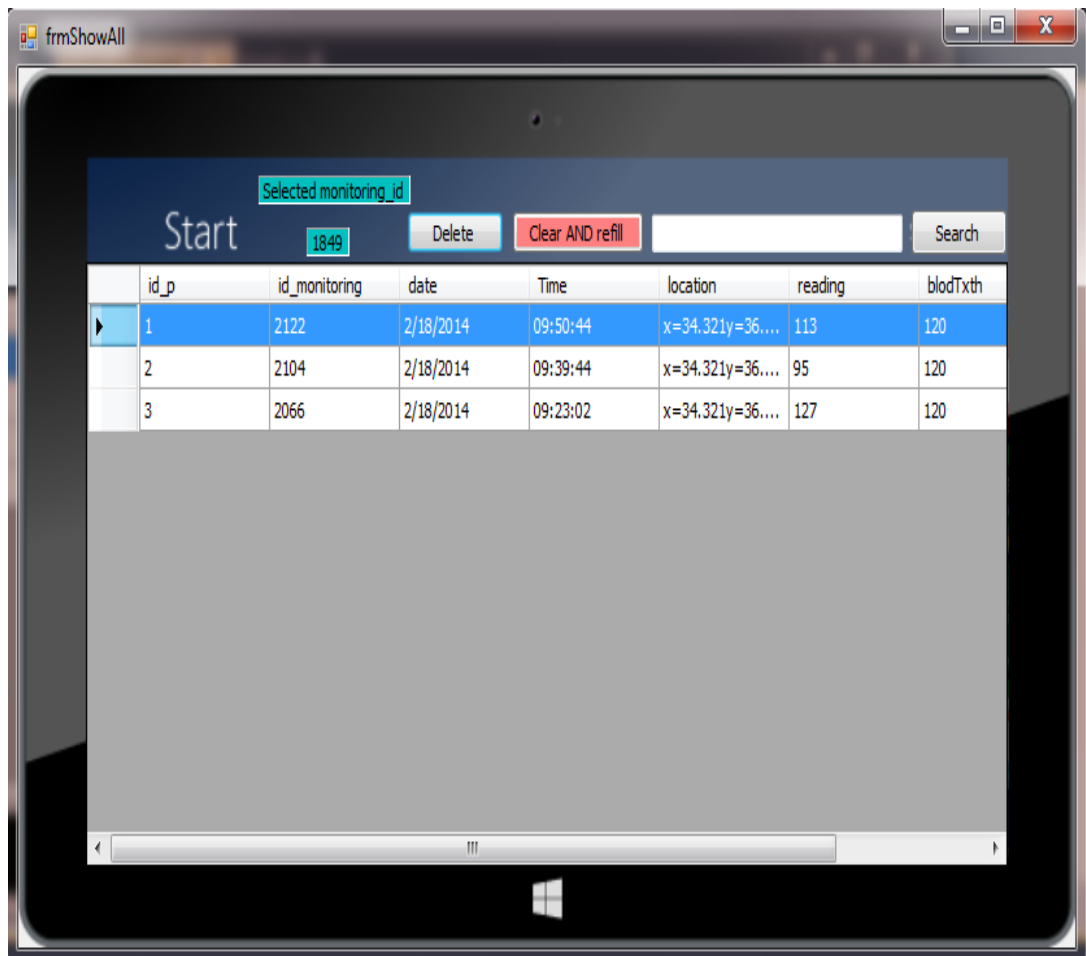

Figure 33: Doctor interface alarms

4.6. Healthcare Provider Tier Design

Healthcare provider is the third tier of our proposed e-healthcare system that contains all system members that help the patients such as doctors, nurses and paramedics.

When a patient had got an abnormal case decided by the medical server, number of alarms will be sent to the healthcare providers depending on the type of the case.

Hereby, the doctor will receive number of alarms from different patients. These alarms will be shown on the screen of the smart device as a notification in order to simplify doctor job. This technique is proposed by the social network (Facebook).

The data that is received by the healthcare provider includes patient ID, date, time of the data, position of the patient and the vital data. The most important thing is the patient ID which helps the healthcare provider to access all patient information that is saved in the database. This process will be done writing patient ID in the website of the system. The website supports the proposed system, first by accessing all

information of the patient by quick search way, second by feedbacking answers to the patient using different ways. All these will be illustrated in the next section.

Moreover, an advanced graphical user interface GUI is designed for the doctor such as displaying the number of alarms for different patients at the same time, searching for a patient using patient id. Finally, a new technique is performed in order to remove patient alarm after satisfying the problems that were encountered.

4.7. Web Site Design

E-Healthcare system usually needs a website in order to allow the subscribers to access the database of the system. In our proposed system, we designed a durable website to obtain an easier way to enter the database. The website is constructed using ASP.net language as mentioned before.



Figure 34: E-Healthcare system website

The proposed website is divided into three different levels specialize in controlling a certain group as follows:

- 1- **First level:** This level is governed by an administrators which is responsible of:
 - A- Registering a new member.
 - B- Registering a new patient.
 - C- Changing system data.
 - D- The persons in this level can reach their information.

In the other word, the administrators are considered the main governor of the entire system and also have all responsibility of the doctors as shown in the following Figs. (35, 36).



Figure 35: Administrator web page

localhost:3740/WebSite21. x

localhost:3740/WebSite21/Default11.aspx

CANKAYA ÜNİVERSİTESİ
1997

SMART E-HEALTH CARE SYSTEM

HOME NEWS STAFF PATIENT ABOUT CONTACT US

Patient Name

Birth Date

gender Male ▾

address

phone

email

Disease

status_normal

status_abnormal_0

status_abnormal_1

status_abnormal_2

status_critical

normal_systol

normal_distol

abnormal_systol_1

abnormal_distol_1

abnormal_systol_2

abnormal_distol_2

critical_systol

critical_distol

kindred_name

kindred_phone

doctor

Notes

user_name

password

Confirm

Add Patient

Figure 36: New patient registration webpage

- 2- **Second Level:** This level deals with system doctors such that it gives the doctors several characteristics as shown in the following steps:
- A- Quick patient information access that consists of public information and recorded monitoring data for the patients. Moreover, taking the sufficient measurements in case of the abnormal patient conditions should be encounter.
 - B- Add or Remove patients form the website.
 - C- The persons in this level can reach their information.

As we mentioned in previous section when the doctor is received an alarm from the patient. The doctor should be going to the website of the system then login. After the doctor logged in, the patient data will be accessed through the (quick patient search by id) link by the doctor. After the doctor is diagnosed the patient's case, suggestion will be feedback to the patient by using email, sms and calling. These steps are illustrated in the following Fig. 37:



Figure 37: Doctor login webpage



Figure 38: Quick patient search by ID

HOME NEWS STAFF PATIENT ABOUT CONTACT US

Input Patient ID

gali_kamel@yahoo.com
patient phon 07901

kindred.phon 07901

id	1	id_monitoring	id_p	date	Time	location	reading	blodTxth	blodTxtl
name	gali kamel			2/18/2014					
age	20	1789	1	12:00:00	09:10:22	x=34.321y=36.432	105	120	80
gender	male			2/18/2014					
address	iraq-baghdad-alsaydeya	1790	1	12:00:00	09:11:12	x=34.321y=36.432	101	120	90
phone	07901111111			2/18/2014					
email	gali_kamel@yahoo.com	1791	1	12:00:00	09:12:33	x=34.321y=36.432	104	123	80
Disease	patient has chest infection			2/18/2014					
status_normal	60-95	1792	1	12:00:00	09:13:34	x=34.321y=36.432	105	120	80
status_abnormal_0	95-110			2/18/2014					
status_abnormal_1	110-120	1794	1	12:00:00	09:14:45	x=34.321y=36.432	106	120	80
status_abnormal_2	50-60			2/18/2014					
status_critical	50-120	1796	1	12:00:00	09:15:11	x=34.321y=36.432	105	120	70
normal_systol	100-140			2/18/2014					
normal_distol	70-90	1798	1	12:00:00	09:16:12	x=34.321y=36.432	105	120	80
abnormal_systol_1	140-170			2/18/2014					

Figure 39: Patient information and take action by doctor

- 3- **Third Level:** Particularly, this level has a direct relation with the nurses and the paramedics that are available in the system. The persons in this level can perform the following:
 - A- Quick search for patients' information exactly as the doctors.
 - B- The persons in this level can reach their information.

In addition, the registered patients in the system are allowed to see their information and can connect to the members of the system with high priority from the visitor of the website. Our web site such as any website included the home page and simple text about the system, with all information that is needed by users or visitor for the system.



Figure 40: Contact us web page

CHAPTER 5

CONCLUSION AND FUTURE WORK

5.1. Conclusion

We built our thesis to serve and satisfy the patients, especially those who have chronic diseases. Hence, we are sure that we can help the medical world using our theory and idea. The first contribution of this thesis is designing a smart system by building a robust network (MANET) specializes in transmitting the data with a low cost and, allows scalability and reliability for the proposed system.

The network we used (MANET) was studied using NS2 simulator in order to make a typical comparison between two well-known routing protocols that are denoted in popular as AODV and DSDV. Basing on the comparison results which based on throughput, PDR, End to End delay and packet lose, we concluded that AODV routing protocol performance was better than DSDV in mobility case under low, medium and high density scenario. In the other hand, our system allows unfixed capacity such that it can hold between 20-120 patients.

The second contribution of this thesis is modeling an intelligent E-Healthcare system by putting in to consideration all requirements that are needed to design such a durable system. In our work, we concentrated on a specific rule to support the decision maker of the system. The term (decision maker) is used in order to simplify health care provider to diagnose patient case and to offer the help if it is needed. The rules we used in our thesis, are represented using data mining techniques because it is considered one of the best techniques that support E-Healthcare system throughout the world. Moreover, a smart application is used to design the health care provider GUI in order to be in touch with the system and to interact with the interested alarms that can be sent in the risky cases. These parameters are programmed using a high level C# language. Last but not least, we designed a firm website to govern the system by providing the factors: accuracy, security and usability for the subscriber

that uses E-Healthcare system. Finally, ASP.net language is applied to design the website for our proposed system.

5.2. Future Work

The proposed decision support E-Healthcare system has many points as a suggestion for future work, including the following:

1. As the telecommunication infrastructure improves in the future, so the enhancement in the system regarding communication quality and faster transmission of data, allow the healthcare professionals to provide better patient services.
2. The development of such system for other wearable medical monitoring applications, such as sugar level.
3. Incorporating more parameters to improve system performance and assist pregnant women.
4. Developing the Patient Server by giving this device the ability to process and analysis the sensed data instead of medical database.

REFERNCES

1. **Shaheen A., (2009)**, “*Intelligent Decision Support System in Diabetic E-Health Care From the perspective of Elders*”, Master Thesis, Department of Computer Science, Blekinge Institute of Technology, Ronneby, Sweden, pp. 17-29.
2. **Priyadarshee S., (2007)**, “*A Health Decision Support System For Rural India*”, Master Thesis, Department of Computer Science and Engineering, National Institute of Technology, Rourkela, India, pp. 25-30.
3. **Mohammad A. B., (2011)**, “*Introducing an e-Health card for Developing Countries: A case study of Bangladesh*”, Master Thesis, Department of Computer and Systems Sciences, Stockholm University, Stockholm, Sweden, pp. 35-48.
4. **Jingyi W., (2011)**, “*A Service-Oriented Architecture for Integrating Clinical Decision Support in a National E-Health System*”, Master Thesis, Department of Computer and Systems Sciences, Stockholm University, Stockholm, Sweden, pp. 8-14.
5. **Allianz Worldwide Care**, <http://www.allianzworldwidecare.com>. (Data Download Date: 25.04.2014).
6. **Shahriyar R., Bari M. F., Kundu G., Ahamed S. I., and Akbar M. M., (2009)**, “*Intelligent Mobile Health Monitoring System (IMHMS)*”, International Journal of Control and Automation, vol. 2, no.3, pp. 13–28.
7. **Mervyn C. A., (2010)**, “*E-Health Diabetes Management System*”, Master Thesis, Department of Computer Science, University of Cape Town, pp. 4-9.
8. **Stefan P., (2011)**, “*ICT System Design & Implementation Using Wireless Sensors to Support Elderly In-home Assistance*”, Master Thesis, Department of Computer and Electrical Engineering, Halmstad University, Halmstad, Sweden, pp. 14-21.
9. **Aggarwal A., Gandhi S., and Chaubey N., (2011)**, “*Performance Analysis Of AODV, DSDV and DSR in MANETs*”, International Journal of Distributed and Parallel Systems, vol. 2, no.6, pp. 167–177.
10. **Gandhewar N., and Patel R., (2011)**, “*Performance Evaluation of AODV protocol in MANET using NS2 Simulator*”, International Journal of Computer Applications, vol. 28, no.5, pp. 1–4.

11. **Jose G., Sunil D., Suresh P., and Supriya N., (2012)**, “*A Simulation Based Study of AODV, DSR, DSDV Routing Protocols in MANET Using NS-2*”, International Journal of Advanced Research in Computer Science and Software Engineering, vol. 2, no.3, pp. 43–51.
12. **Information Builders**, <http://www.informationbuilders.com/decision-support-systems-dss/>. (Data Download Date: 28.01.2014).
13. **Decision Support Systems**, <http://www.repec.org/>. (Data Download Date: 23.03.2014).
14. **Druzdzel M., and Flynn R., (2002)**, “*Decision Support Systems*”, Decision Systems Laboratory School of Information Sciences and Intelligent Systems Program, University of Pittsburgh, New York, America, vol. 67, no. 30, pp. 120–133.
15. **Science and Education Publishing**, <http://pubs.sciepub.com/>. (Data Download Date: 13.02.2014).
16. **Verulkar S., Limkar M., (2012)**, “*Real Time Health Monitoring Using GPRS Technology*”, International Journal of Computer Science and Network, Mumbai University, vol. 1, no. 3, pp. 310–323.
17. **Abidoye A., Ayofe N., Adesina A., Agbele K. and Nyongesa O., (2011)**, “*Using Wearable Sensors for Remote Healthcare Monitoring System*”, Journal of Sensor Technology, vol. 1, pp. 22–28.
18. **Vyas N. and Pal P., (2012)**, “*E-Healthcare Decision Support System Based on Ontology Learning: A Conceptual Model*”, International Journal of Computer Applications, vol. 59, no. 9, pp. 12–16.
19. **Poon C. and Zhang Y., (2006)**, “*A Novel Biometrics Method to Secure Wireless Body Area Sensor Networks for Telemedicine and M-Health*”, IEEE Communications Magazine, vol. 06, pp. 73-81.
20. **Lauzurica D. B., (2012)**, “*Development of a ZigBee Wireless Sensor Node*”, Master Thesis, Department of Division of Intelligent Future Technologies, Mälardalen University, Västerås, Sweden, pp. 42-46.
21. **Alemdar H. and Ersoy C., (2010)**, “*Wireless Sensor Networks for Healthcare*”, Computer Networks Research Laboratory, vol. 54, pp. 2688–2710.

22. **Rashid A., Abd Rahim M., Syed S., Arifin, Syed S. and Faisal N. , (2008)**, “*Wireless Biomedical Sensor Network for Home-based ECG Monitoring*”, *Int. J. Biomedical Engineering and Technology*, vol. 47, no. 4, pp. 639–649.
23. **Dinkar P., Gulavani A., Ketkale S., Kadam P. and Dabhade S., (2013)**, “*Remote Health Monitoring using Wireless Body Area Network*”, *International Journal of Engineering and Advanced Technology*, vol. 2, no. 4, pp. 399–402.
24. **Iarsson T., (1998)**, “*Routing Protocols in Wireless Ad-hoc Network-A Simulation Study*”, Master Thesis, Department of Computer Science and Engineering, Lulea University of Technology, Stockholm, Sweden, pp. 22-34.
25. **Kaur S. and Sharma C., (2013)**, “*An Overview of Mobile Ad hoc Network: Application, Challenges and Comparison of Routing Protocols*”, *Journal of Computer Engineering*, vol. 11, pp. 07–11.
26. **Dipobagio M., (2010)**, “*An Overview on Ad Hoc Networks*”, Institute of Computer Science, Freie Universität Berlin, pp. 1–9.
27. **Kumar M. and Mishra R., (2008)**, “*An Overview of MANET: History, Challenges and Applications*”, *Indian Journal of Computer Science and Engineering*, vol. 3, no. 1, pp. 121–125.
28. **Goyal P., Parmar V. and Rishi R., (2011)**, “*MANET: Vulnerabilities, Challenges, Attacks, Application*”, *International Journal of Computational Engineering & Management*, vol. 11, no. 5, pp. 32–37.
29. **Shrivastava A., Chander N., (2010)**, “*Overview of Routing Protocols in MANET’s and Enhancements in Reactive Protocols*”, Department of Computer Science, Lamar University, pp 1–8.
30. **Abd Rahman A. and Zukarnain Z., (2014)**, “*Performance Comparison of AODV, DSDV and I-DSDV Routing Protocols in Mobile Ad Hoc Networks*”, *European Journal of Scientific Research*, vol. 31, no. 4, pp. 566–576.
31. **Gupta S. K. and Saket R. K., (2011)**, “*Performance Metric Comparison of Aodv And Dsdv Routing Protocols In Manets Using Ns-2*”, *International Journal of Research and Reviews in Applied Sciences*, vol. 7, no. 3, pp. 339–350.
32. **Ghosekar P., Katkar G. and Ghorpade P., (2010)**, “*Mobile Ad Hoc Networking: Imperatives and Challenges*”, *International Journal of Computer Applications*, vol. 1, no. 1, pp. 153–158.

33. **Abdullah A. A., (2013)**, “*Simulating Dynamic Node Movements for MANET in NS-2*”, Master Thesis, Department of Computer Science, University of New Brunswick, Fredericton, Canada.
34. **Alyeksyeyenkov Y., Abdullah M. and Nafea M., (2014)**, “*Behavior Analysis Of Routing Protocols For A Health Decision Support System*”, International Journal of Computer Engineering & Technology, vol. 5, no. 4, pp. 194–201.
35. **Microsoft webpage**, www.sql_server_r2_2008.com. (Data Download Date: 09.01.2014).
36. **Visual studio webpage**, <http://www.visualstudio.com>. (Data Download Date: 15.12.2013).
37. **MNT Knowledge Center webpage**, <http://www.medicalnewstoday.com>. (Data Download Date: 14.02.2014).

APPENDICES A

A. CURRICULUM VITAE

PERSONAL INFORMATION

Surname, Name: AL-QAISI, Mustafa

Date and Place of Birth: 19 January 1989, Baghdad - Iraq

Marital Status: Single

Phone: +90 539 839 85 98, +964 771 237 82 00

Email: Mustafa_real64@yahoo.com

EDUCATION

Degree	Institution	Year of Graduation
M.Sc.	Çankaya Univ., Computer Engineering	2014
B.Sc.	University of Technology	2011
High School	Al-Kindi High School	2005

WORK EXPERIENCE

Year	Place	Enrollment
2011 January	Iraqi Arab Contract Company	Computer Engineer
2009 May	SIEMENS Company	Maintenance Engineer

FOREIN LANGUAGES

Arabic (Mother Language), Advanced English, Beginner Turkish

PUBLICATIONS

Y. Alyeksyeyenkov, M. Abdullah and M. Nafea, (2014), “*Behavior Analysis Of Routing Protocols For A Health Decision Support System,*” International Journal of Computer Engineering & Technology, vol. 5, no. 4, pp. 194–201.

HOBBIES

Football, Travelling, Movies, Swimming