



**ANALYSIS AND DESIGN OF BROADBAND MICROWAVE DISTRIBUTED
AMPLIFIERS**

REYHAN YURT

JUNE 2017

**ANALYSIS AND DESIGN OF BROADBAND MICROWAVE DISTRIBUTED
AMPLIFIERS**

**A THESIS SUBMITTED TO
THE GRADUATE SCHOOL OF NATURAL AND APPLIED
SCIENCES OF
ÇANKAYA UNIVERSITY**

**BY
REYHAN YURT**

**IN PARTIAL FULFILLMENT OF THE REQUIREMENTS FOR THE
DEGREE OF
MASTER OF SCIENCE
IN
THE DEPARTMENT OF
ELECTRONIC AND COMMUNICATION ENGINEERING**

JUNE 2017

Title of the Thesis: **Analysis and design of broadband microwave distributed amplifiers.**

Submitted by **Reyhan Yurt**

Approval of the Graduate School of Natural and Applied Sciences, Çankaya University.

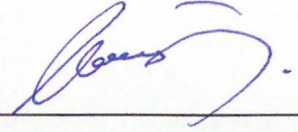

Prof. Dr. Can ÇOĞUN
Director

I certify that this thesis satisfies all the requirements as a thesis for the degree of Master of Science.

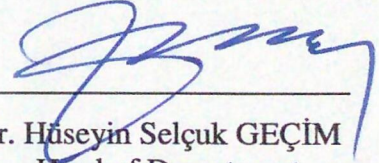

Prof. Dr. Hüseyin Selçuk GEÇİM
Head of Department

This is to certify that we have read this thesis and that in our opinion it is fully adequate, in scope and quality, as a thesis for the degree of Master of Science.

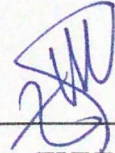

Prof. Dr. Halil Tanyer EYYUBOĞLU
Supervisor

Examination Date: 29.06.2017

Examining Committee Members

Assoc. Prof. Dr. Fırat HARDALAÇ

(Gazi Univ.)

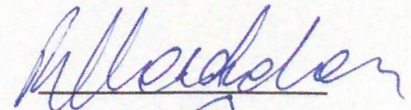

Prof. Dr. Halil Tanyer EYYUBOĞLU

(Çankaya Univ.)

Assist. Prof. Dr. Göker ŞENER

(Çankaya Univ.)

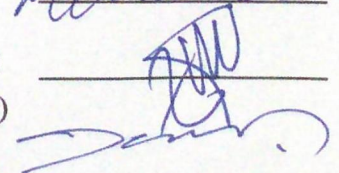

STATEMENT OF NON-PLAGIARISM PAGE

I hereby declare that all information in this document has been obtained and presented in accordance with academic rules and ethical conduct. I also declare that, as required by these rules and conduct, I have fully cited and referenced all material and results that are not original to this work.

Name, Last Name : Reyhan Yurt
Signature : 
Date : 29.06.2017

ABSTRACT

Analysis and design broadband microwave distributed amplifiers

YURT, Reyhan

M.Sc., Department of Electronic and Communication Engineering

Supervisor: Prof. Dr. Halil Tanyer EYYUBOĞLU

June 2017, 78 pages

In this thesis, microwave amplifier design techniques are analyzed and especially distributed technique is applied for broadband amplifier in L-S band according to the IEEE radar-frequency band. Conventional distributed amplifier (CDA) design topology is implied at 1-3 GHz frequency range. Available gain is obtained 14+2.5 dB with flatness. Optimum number of stages of amplifier is investigated and the result is evaluated as restriction of this topology so amplifier is designed with one stage. To increase gain performance cascaded single stage distributed amplifier (CSSDA) topology is analyzed and designed as 2-CSSDA at 1-3 GHz. In this design, almost 26 dB is obtained as peak value of available gain near 2.7 GHz and available gain is observed as 23.9+2 dB with simulations. CSSDA designed topology can be integrated with breakthrough circuit and approach so that more qualified distributed amplifier (DA) may be improved.

Keywords: Broadband Microwave Amplifier, Distributed Amplifier, Conventional Distributed Amplifier, CSSDA

ÖZ

Mikrodalga Geniş Bantlı Dağıtılmış Yükselteçlerin Analizi ve Tasarımı

YURT, Reyhan

Yüksek Lisans, Elektronik ve Haberleşme Mühendisliği Anabilim Dalı

Tez Yöneticisi: Prof. Dr. Halil Tanyer EYYUBOĞLU

Haziran 2017, 78 sayfa

Bu tezde, mikrodalga yükselteç teknikleri incelenmiş ve IEEE radar frekans bandına göre özellikle dağıtılmış yükselteç tekniği L-S bantta geniş bantlı mikrodalga yükselteç için uygulanmıştır. Geleneksel dağıtılmış yükselteç tasarım topolojisi 1-3 GHz frekans aralığında uygulanmıştır. Mevcut kazanç $14+2.5$ dB düzgün olarak elde edilmiştir. Yükseltecin en uygun aşama sayısı araştırılmış ve sonuç bu topolojinin bir sınırlaması olarak değerlendirilmiştir ve bu yüzden yükselteç bir aşama ile tasarlanmıştır. Kazanç performansını arttırmak için, seri bağlı tek aşamalı dağıtılmış yükselteç topolojisi incelenmiştir ve 1-3 GHz 'de 2-SBTADY olarak tasarlanmıştır. Bu tasarımda, simülasyonlar ile yaklaşık 26 dB mevcut kazancın en yüksek değeri olarak 2.7 GHz civarında elde edilmiştir ve mevcut kazanç $23.9+2$ dB olarak gözlemlenmiştir. Tasarlanan SBTADY topolojisi, büyük yenilik içeren devre ve yaklaşımla entegre edilebilir böylece daha nitelikli DY geliştirilebilir.

Anahtar Kelimeler: Geniş Bantlı Mikrodalga Yükselteç, Dağıtılmış Yükselteç, Geleneksel Dağıtılmış Yükselteç, Seri Bağlı Tek Aşamalı Dağıtılmış Yükselteç

to my parents and nephew Ömer Asaf,

ACKNOWLEDGEMENTS

I would like to thank my supervisor Prof. Dr. Halil Tanyer EYYUBOĞLU for his guidance and suggestions throughout this thesis study.

I would like to express special thanks to Doç. Dr. Mehmet YÜCEER. I am really thankful to him because I started to study at this field with just one course and he was so helpful for my first studies in microwave amplifier world as instructor of this course. Moreover, he helped me to develop myself and gain a point of view in designing microwave amplifier.

I would like to thank the jury members for their valuable comments on the thesis.

I am really thankful to Dean of Engineering Faculty of Yalova University Prof. Dr. Mustafa ÖZTAŞ for their valuable support.

I am grateful to my family for their support and their unfailing encouragement during this study.

TABLE OF CONTENTS

STATEMENT OF NON PLAGIARISM.....	iii
ABSTRACT.....	iv
ÖZ.....	v
ACKNOWLEDGEMENTS.....	vii
TABLE OF CONTENTS.....	viii
LIST OF FIGURES.....	x
LIST OF TABLES.....	xiii
LIST OF ABBREVIATIONS.....	xiv
CHAPTERS:	
1. INTRODUCTION.....	1
1.1. RF and Microwave Amplifiers	1
1.2. Two Ports Network.....	2
1.3. Impedance Matching and Main Parameters.....	5
1.4. Organization of Thesis.....	11
2. BROADBAND AMPLIFICATION.....	12
2.1. Overview of Broadband Amplifiers	12
2.2. Methods of Broadband Amplifiers.....	12
2.3. Distributed Amplification.....	16
3. ANALYSIS OF DISTRIBUTED AMPLIFIER.....	19
3.1. Principles of Distributed Amplifier.....	19
3.2. Analytical Analysis of Distributed Amplifier.....	21
3.3. About Transistors Used in Case Study.....	24
3.4. Stability Analysis.....	25
3.5. Bias Circuit of Used Transistor.....	27
3.6. Input and Output Matching Circuits.....	28

4. DESIGN OF THE DISTRIBUTED AMPLIFIER.....	32
4.1. Design and Simulation Results of Conventional Distributed Single Stage Distributed Amplifier.....	32
4.2 Proposed Design of Single Stage Distributed Amplifier.....	42
4.3 2- Cascaded Single Stage Distributed Amplifier.....	49
5. CONCLUSION.....	55
REFERENCES.....	58
APPENDICES.....	61
A. DIE MODEL OF ATF-54143.....	61
B. TOUCHSTONE FILE OF ATF-54143 FOR $V_{ds}= 3V$, $I_{ds}= 60mA$	62

LIST OF FIGURES

FIGURES

Figure 1	Basic block diagram of microwave transistor amplifier [3].....	2
Figure 2	Two port network.....	3
Figure 3	Incident and emerging waves.....	4
Figure 4	Input matching on Smith Chart.....	6
Figure 5	Output matching on Smith Chart.....	7
Figure 6	Input and output matching networks (left-input, right-output) ...	7
Figure 7	WithImpedanceMatching and WithoutImpedanceMatching circuit schematics.....	8
Figure 8	Comparison between matched and unmatched network.....	9
Figure 9	Lossy matched amplifier topology (given in [15]).....	13
Figure 10	Balanced amplifier topology (given in [9]).....	14
Figure 11	Feedback amplifier topology (given in [15])	16
Figure 12	Basic diagram of N-stage distributed amplifier (given in [9])...	18
Figure 13	Simplified schematic of 2 – DA with lumped elements [21].....	19
Figure 14	Basic concept of conventional distributed amplifier.....	20
Figure 15	The equivalent circuit of a single unit cell of the gate line [9]...	21
Figure 16	The equivalent circuit of a single unit cell of the drain line [9]..	22
Figure 17	Stability analysis of ATF-54143 at operating frequency range for $V_{ds}=3V$ and $I_{ds}=60\text{ mA}$ s.....	25
Figure 18	Stability circuit schematic.....	26
Figure 19	Stability analysis after the connecting stability circuit.....	26

Figure 20	Bias circuit schematic.....	27
Figure 21	Input matching on Smith Chart	30
Figure 22	Output matching on Smith Chart.....	31
Figure 23	Input and output impedance matching circuits (left -input matching, right –output matching).....	31
Figure 24	Basic schematics of T type and L type artificial transmission lines [25].....	34
Figure 25	Conventional single stage distributed amplifier schematic.....	35
Figure 26	Available gain single stage distributed amplifier.....	36
Figure 27	S parameters in logarithmic magnitude (in dB) of conventional SSDA.....	37
Figure 28	Input matching on Smith Chart.....	38
Figure 29	Output matching on Smith Chart.....	39
Figure 30	Input and output matching circuits of conventional SSDA.....	39
Figure 31	Schematic of impedance matched conventional SSDA.....	40
Figure 32	Available gains of SSDA and impedance matched SSDA.....	41
Figure 33	Stability control of conventional single stage distributed amplifier.....	42
Figure 34	Optimized single stage distributed amplifier.....	45
Figure 35	Gain performance of optimized SSDA and conventional SSDA amplifier designs	46
Figure 36	Stability Analysis of optimized single stage distributed amplifier.....	47
Figure 37	S parameters (in dB) of optimized single stage distributed amplifier.....	48
Figure 38	Designed 2-CSSDA schematic.....	49
Figure 39	Stability analysis of 2-CSSDA	50
Figure 40	Gain performance of 2-Cascaded SSDA	51
Figure 41	S Parameters of 2-Cascaded SSDA	52

Figure 42	Gain analyses of 2-CSSDA and conventional SSDAs	53
Figure 43	Noise figure comparison of conventional DAs and CSSDA	54



LIST OF TABLES

TABLES

Table 1	Input and output impedances of unconditionally stable transistor at 1.6-2.4 GHz.....	6
Table 2	Input and output impedances of biased circuit for impedance matching circuits.....	31
Figure 3	Input and output impedances of biased circuit at 1-3 GHz.....	39

LIST OF ABBREVIATIONS

RF	Radio Frequency
DA	Distributed Amplifier
TWT	Traveling Wave Tube
S-Parameters	Scattering Parameters
MTA	Microwave Transistor Amplifier
CAD	Computer-Aided Design
BJT	Bipolar Junction Transistor
FET	Field Effect Transistor
PHEMT	Pseudomorphic High Electron Mobility Transistor
CDA	Conventional Distributed Amplifier
CSSDA	Cascaded Single Stage Distributed Amplifier
SSDA	Single Stage Distributed Amplifier

CHAPTER 1

INTRODUCTION

1.1 RF and Microwave Amplifiers

In radio frequency and microwave communication systems, amplifier is one of the most significant components. Signal amplification is required to transfer message signal with determined power gain or and noise figure. Moreover, amplifier can be designed for transmitter and receiver antenna to achieve transmission with undistorted signal, high gain and low noise figure thanks to low design approaches.

In the past, amplification function was carried out with Klystron, traveling-wave tubes (TWT) and magnetrons [1]. However, today developing semi-conductor technologies has provided opportunities to use transistors. Therefore, solid state amplifiers [2] can be designed for systems which need approximately at most 100 watts.

According to the system which includes amplifier in, design criteria varies. High-gain, bandwidth and low noise are the most important amplifier requirements for microwave engineering areas such as radars, satellite communication and optical communication also, point to point, point to multipoint and multipoint to multipoint radio links. In addition, transistor amplifiers are commonly preferred in today wireless communication technologies because of these basic requirements.

MTA (Microwave Transistor Amplifier) fundamentally consists of input and output matching circuits, bias circuit and stability, gain-flatness and low noise networks can be made available if these features are placed in system requirements. 50Ω , 75Ω or

100Ω system impedances are matched to active device input and output port according to its scattering parameters which is determined based on frequency.

In this study, 50Ω system impedance is matched with transistor according to its gate to source and drain to source capacitances by drawing artificial inductive transmission lines for all configurations of distributed amplifier. After that, by helping AWR Microwave Office CAD tool simulations are carried out. Also, simulation results are used to analyze designed amplifier circuit by using AWR Microwave Office CAD tool as design environment. Moreover, schematics are drawn to explain topologies in thesis in AWR Microwave Office Project-Circuit Schematics part such as in Fig.1 represents basic transistor amplifier diagram.

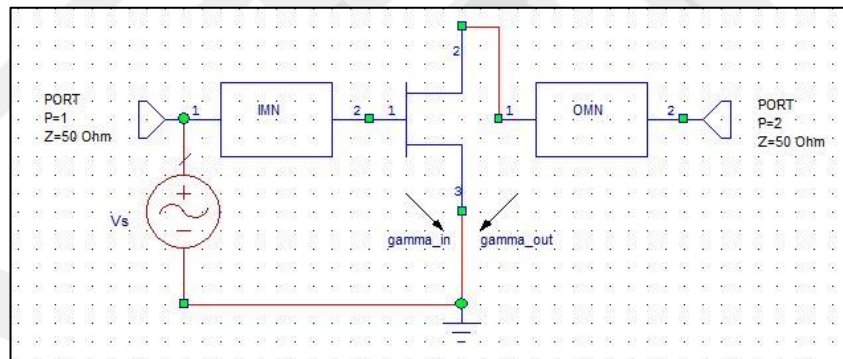

Figure 1 Basic block diagram of microwave transistor amplifier [3]

1.2 Two Port Network

System ports which have one or more ports are accepted as networks. They correspond to a pair of electrical terminals describe electrical behavior of active and passive devices. As in Fig.2 these ports are named “Port 1” and “Port 2” or input and output ports. When designing amplifier mostly input and output ports are used.

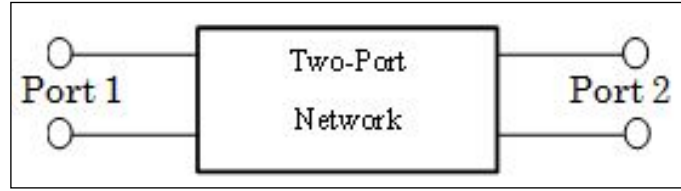

Figure 2 Two port network

Z, Y, ABCD and Scattering Parameters (S-Parameters) are significant transfer variables to figure out terminal currents which are I_1 and I_2 and terminal voltages V_1 and V_2 . Z parameters are expressed with terminal currents whereas Y parameters are expressed with terminal voltages.

$$V_1 = Z_{11}I_1 + Z_{12}I_2 \quad \text{and} \quad V_2 = Z_{21}I_1 + Z_{22}I_2 \quad (1.1)$$

$$I_1 = Y_{11}V_1 + Y_{12}V_2 \quad \text{and} \quad I_2 = Y_{21}V_1 + Y_{22}V_2 \quad (1.2)$$

$$V_1 = AV_2 + BI_2 \quad \text{and} \quad I_1 = CV_2 + DI_2 \quad (1.3)$$

- A: open-circuit, inverse voltage gain
- B: short-circuit, forward transfer function
- C: open-circuit, forward transfer admittance
- D: short-circuit, inverse forward current gain

In addition, ABCD parameters are mixture of impedance and admittance variables [2, 3].

Matthews [4] explains that current and voltage measurements at high frequency differently from at low frequencies in reference to conventional circuit theory become ambiguous. However, it is possible to measure incident and emerging waves. For this reason, Z, Y and ABCD parameters are not always the most suitable transfer parameters for microwave network applications. Moreover, many active devices

become unstable when they are terminated with open and short circuits so S parameters provide an advantage for active network.

Wave propagation is considered in short-wave length circuit at high frequencies. Incident and emerging waves affect many dimensions such as power, phase, reflection coefficients from load to source [4, 5, 6]. Therefore, physical terminal behaviors such as reflection coefficient, return loss, gain and the numbers of incident and emerging waves are expressed by means of complex S- parameters based upon frequency. In Fig.3, there is a diagram which represents basically incident and emerging wave's relation with network.

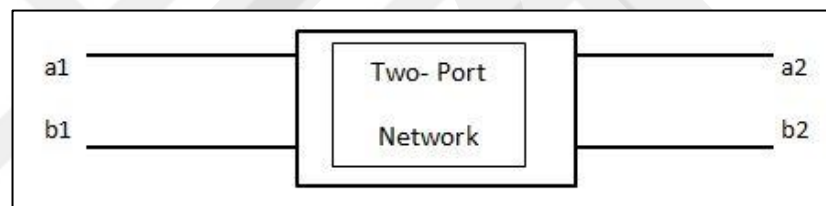

Figure 3 Incident and emerging waves

a_n : Incident wave

b_n : Emerging wave

Z_0 : Characteristic impedance

V_n^+ : Potential toward network

V_n^- : Potential outward network

The following equations define the wave numbers and S-parameters for two port network [2, 3, 4, 6] :

$$a_n = \frac{V_n^+}{\sqrt{Z_0}} \quad \text{and} \quad b_n = \frac{V_n^-}{\sqrt{Z_0}} \quad (1.4)$$

$$b_1 = S_{11}a_1 + S_{12}a_2 \quad \text{and} \quad b_2 = S_{21}a_1 + S_{22}a_2 \quad (1.5)$$

S_{11} parameter of an amplifier express input reflection coefficient [3] and its logarithmic magnitude defines input return loss. In other words, input return loss shows input impedance of the two port network and system impedance relation.

$$\text{input return loss} = |20 \log||S_{11}| \text{ in dB} \quad (1.6)$$

S_{22} parameter is similar with S_{11} and represents output reflection coefficient [3], logarithmic magnitude measures the output return loss. S_{22} parameter shows approximation output impedance of the network to system impedance.

$$\text{output return loss} = |20 \log||S_{22}| \quad (1.7)$$

Lower return losses provide higher performance for an amplifier owing to low loss of amplifier. Moreover S_{12} parameter (backward transmission coefficient) [3] express reverse gain and it is preferred very low values to obtain high S_{21} parameter, high gain.

1.3 Impedance Matching and Main Parameters

Impedance matching plays an important role to transfer maximum power from input port to output port. Source and load reflection coefficients are matched with respectively input and output network of active network so that, propagating wave power is absorbed by the load and high signal-to-noise (SNR) ratio is obtained [2, 3, 7]. Impedance matching especially broadband impedance matching configurations will be explained in detail in next chapters.

Matching network importance for gain is showed with integrating matching networks to active device at 1.6-2.4 GHz frequency band which is selected to illustration of matching circuits design. It is used that ATF54143 Avago Technologies transistor as

a model and it is unconditionally stable with stability circuits. Fig.4 shows the stability analysis graph of parameters of stability conditions.

Frequency	Input Impedance	Output Impedance
1.6 GHz	$38.626 - j35.298$	$69.649 - j35.562$
1.8 GHz	$35.498 - j31.922$	$66.969 - j33.837$
2 GHz	$32.941 - j28.452$	$64.840 - j32.043$
2.2 GHz	$30.741 - j25.044$	$63.064 - j33.348$
2.4 GHz	$29.068 - j21.930$	$61.634 - j28.683$

Table 1 Input and output impedances of unconditionally stable transistor at 1.6-2.4 GHz

Table 1 shows the input and output impedances of 1.6-2.4 GHz which is selected for illustration of impedance matching importance for gain. According to this table, input and output matching circuits are formed with AWR Microwave Office. Moreover Fig.4 represents input match operation on Smith Chart and Fig.5 represents output match operation on Smith Chart.

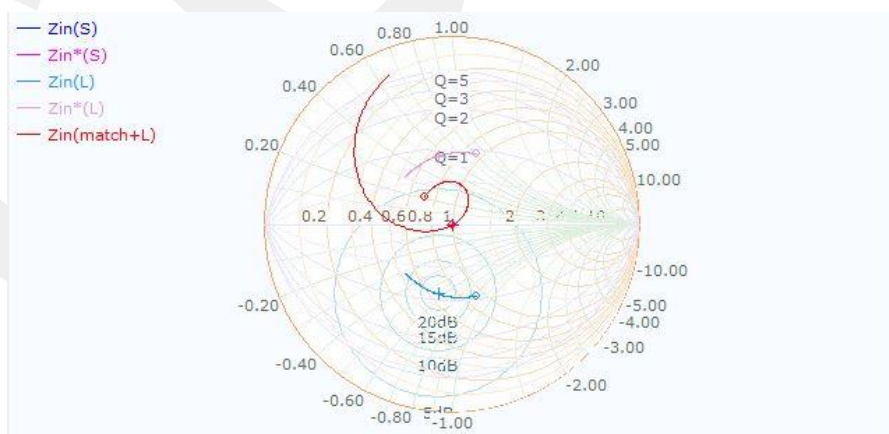

Figure 4 Input matching on Smith Chart

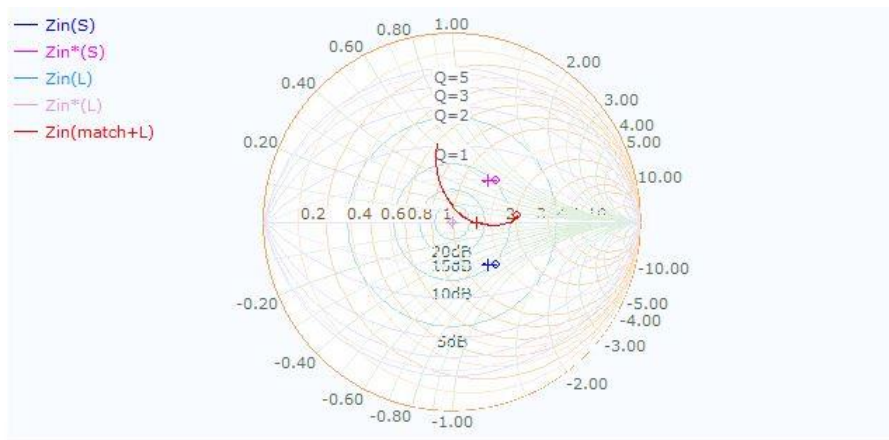

Figure 5 Output matching on Smith Chart

After matching operation for input and output ports of active device, matching circuits are formed as in Fig. 6.



Figure 6 Input and output matching networks (left-input, right-output)

These matching circuits which are designed with T-type low pass matching technique are integrated to active device as sub circuits so that WithImpedanceMatching schematic is designed. In Fig. 7, WithImpedanceMatching schematic and WithoutImpedanceMatching schematic are shown.

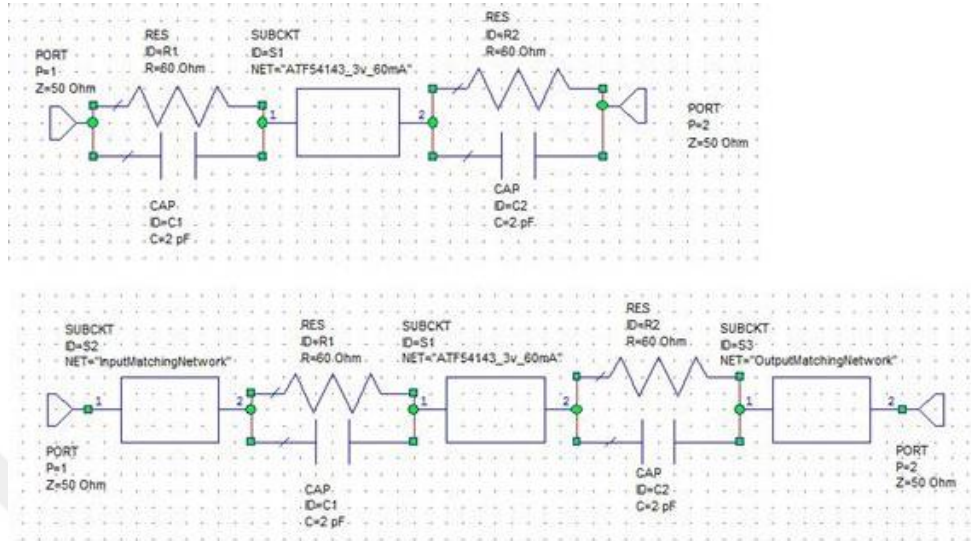

Figure 7 WithImpedanceMatching and WithoutImpedanceMatching circuit schematics

Transistor available gain which is calculated with reference to its S-parameters for its entire operating frequency band and results are expressed with WithoutImpedanceMatching line. Other side, WithImpedanceMatching line shows available gain for 1.6-2.4 GHz band. Therefore, unmatched circuits decrease gain of network. Fig.8 which is explicitly explained impedance matching network function.

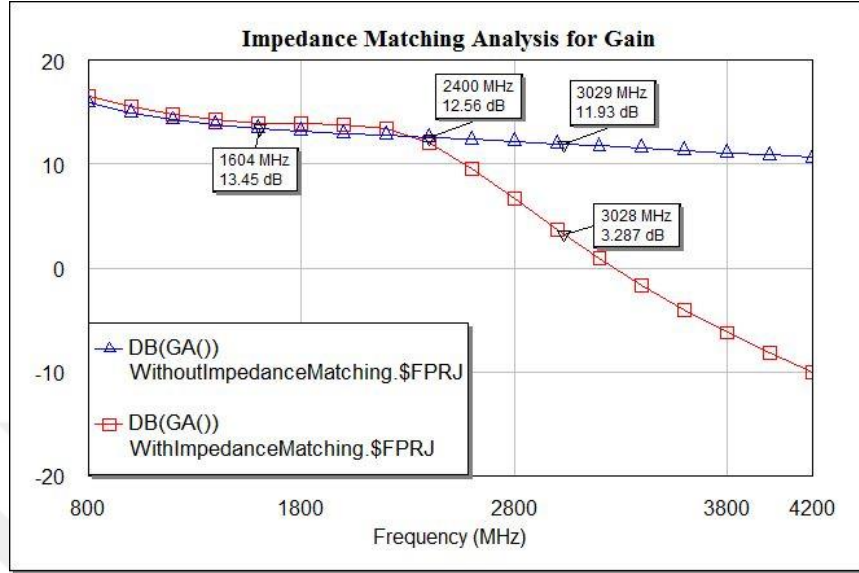

Figure 8 Comparison between matched and unmatched network

The following parameters and equations to design and analysis microwave transistor amplifier are defined in detail in literature [2, 3] :

Γ_{in} (gamma_in) and Γ_{out} (gamma_out) as shown in Fig.1 express respectively reflection coefficients measured from input port to device and from output port to device.

$$\Gamma_{in} = S_{11} + \frac{S_{12}S_{21}\Gamma_L}{1-S_{22}\Gamma_L} \quad \text{and} \quad \Gamma_{out} = S_{22} + \frac{S_{12}S_{21}\Gamma_S}{1-S_{11}\Gamma_S} \quad (1.8)$$

$$\Gamma_L = \frac{Z_L - Z_0}{Z_L + Z_0} \quad \text{and} \quad \Gamma_S = \frac{Z_S - Z_0}{Z_S + Z_0} \quad (1.9)$$

Z_0 is the characteristic impedance of the two port network. Source and load reflection coefficients which are found with solution of Eq.1.9 are also parameters of Eq.1.8.

G_T transducer power gain, G_P the power gain (also called operating power gain) and G_A are called as following equations:

$$G_T = \frac{P_L}{P_{AVS}} = \frac{\text{power delivered to the load}}{\text{power available from the source}} \quad (1.10)$$

$$G_P = \frac{P_L}{P_{IN}} = \frac{\text{power delivered to the load}}{\text{power input to the network}} \quad (1.11)$$

$$G_A = \frac{P_{AVN}}{P_{AVS}} = \frac{\text{power available from the network}}{\text{power available from the source}} \quad (1.12)$$

Moreover, one of the most important requirements is stability analysis to design without oscillations throughout operating frequency band [8, 9]. If Rollet's condition and auxiliary condition is provided, amplifier will be unconditionally stable [3, 9]. K and Δ parameters, also their test condition to ensure unconditional stability are defined as below equations [3, 9] :

$$K = \frac{1 - |S_{11}|^2 - |S_{22}|^2 + |\Delta|^2}{2|S_{12}S_{21}|} > 1 \quad (1.13)$$

$$|\Delta| = |S_{11}S_{22} - S_{12}S_{21}| < 1 \quad (1.14)$$

A single parameter μ has been defined in Ref. [8] for unconditionally stable two or more networks and its condition is followed as:

$$\mu = \frac{1 - |S_{11}|^2}{|S_{22} - \Delta S_{11}^*| + |S_{12}S_{21}|} > 1 \quad (1.15)$$

As a result, if $\mu > 1$, the transistor is unconditionally stable. In design process, μ will be investigated through whole frequency band for source and load.

1.4 Organization of the Thesis

This thesis is divided into five chapters. All studies include microwave transistor amplifier analysis and design techniques. Especially, broadband distributed amplifier technique is investigated and example designs are analyzed.

Chapter 1 consists of introduction with general explanation, microwave amplifier main parameters, impedance matching and design equations belong to common theory for microwave transistor amplifier.

Chapter 2 involves broadband design approaches and basically distributed amplifier theory and its equations.

In Chapter 3, distributed amplifier design requirements and its analytical analysis also, design process is investigated in detail.

In Chapter 4, conventional single stage distributed amplifier at 1-3 GHz frequency band and cascaded single stage distributed amplifier are designed and their simulation results are evaluated.

Chapter 5 is the conclusion part which involves comparisons between designed distributed amplifiers according to gain, noise figure and return losses according to S parameters.

CHAPTER 2

BROADBAND AMPLIFICATION

2.1 Overview of Broadband Amplifiers

Common design methods of broadband amplifiers to obtain more bandwidth are briefly mentioned in this chapter. Moreover, distributed amplification as proposed method is discussed. In literature, many works have done to increase bandwidth and gain in order to cover demand high data rate and capacity in different frequency bands for different applications and standards.

For 1-13 GHz bandwidth, Traveling-Wave Amplifier [10] approach was implemented with GaAs FET and 9 dB±1dB gain was obtained. Another study from literature [11] demonstrated four-cascaded single stage distributed amplifier (CSSDA) by using HJ-FET as an active device with internal characteristic impedance consideration and achieved 36.7±1 dB gain in 1-10 GHz bandwidth. Finally, one of the important configurations from the literature is cascaded reactively terminated single stage distributed amplifier (CRTSSDA) for 2-18 GHz operating frequency range. In this paper [12], a solution was investigated to improve gain performance of distributed amplifier configurations.

2.2 Methods of Broadband Amplifiers

According to Pozar [9], $|S_{21}|$ decreases with at the rate of 6 dB/octave so broadband matching networks require corresponding different S_{21} parameters versus operating frequency band. Fundamentally, gain-bandwidth amplifier design [3] comprises

some difficulties as a result of the fact that some common methods are improved to overcome complexities. They are listed as:

- **Compensating Matching (Lossy Matched):**

Compensating matching technique is also implied lossy matched in literature. To aim is compensating the variation of $|S_{21}|$ in inversely proportion to frequency. As the operating frequency increases the magnitude of S_{21} (gain performance) decreases by reason of transistor characterization [13].

It is mentioned in this paper [14], lossy matched amplifier is similar with L-C matched amplifier at high frequencies and C-R coupled amplifier at low frequencies. L-C components do not have effect at low frequencies in a similar manner; R-C coupling effect is negligible at high frequencies [14]. Another lossy matched circuit configuration includes resistances.

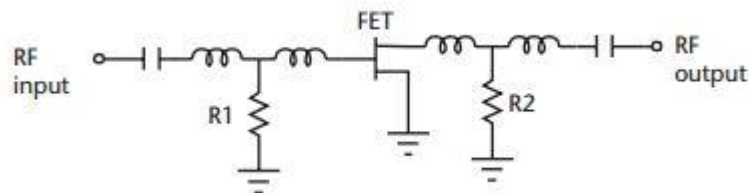

Figure 9 Lossy matched amplifier topology (given in [15])

Fig.9 represents a basic circuit diagram which uses R1 and R2 resistors respectively for input port and output port. These resistances provide gain-flatness over operating frequency thanks to high attenuation at low frequencies and low attenuation at high frequencies [15].

- **Balanced Amplification:**

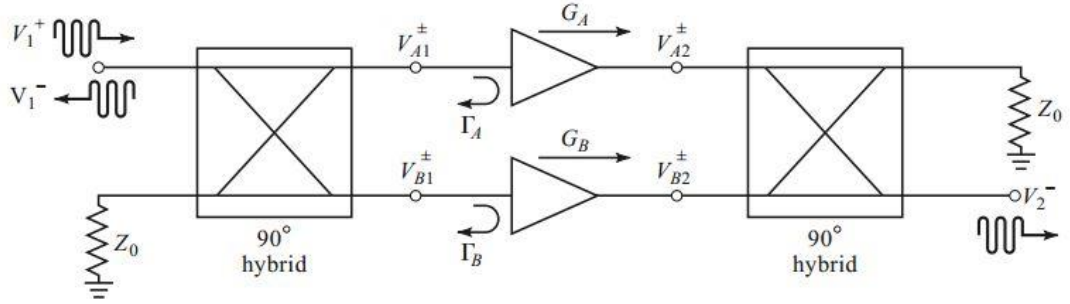

Figure 10 Balanced amplifier topology (given in [9])

The basic idea behind of this technique is that input and output reflections are prevented by way of two 90° couplers. However, bandwidth is limited about two octaves by the coupler because of decrease in power gain by about 6 dB/ octave [3, 9]. In Fig.10, basic balanced amplifier topology is given.

The coupler at the input divides incident signals into two equal amplitude parts with 90° phase difference. The second coupler which is at the output of the amplifier recombines the amplified signal. With an improved impedance matching, phasing properties of couplers prevent reflected signal at the input and output of the balanced amplifier [9]. Hence, in spite of its complexity and unimproved gain-bandwidth characteristic there are some beneficial features given in [9]: proper gain performance, noise figure and stability owing to successful impedance matching.

Shown in Fig.6, for ideal couplers voltages of incident signals can be expressed as

$$V_{A1}^+ = \frac{1}{\sqrt{2}}V_1^+ \quad \text{and} \quad V_{B1}^+ = \frac{-j}{\sqrt{2}}V_1^+ \quad (2.1)$$

The voltages at the output can be defined as V_2^- and found following equation.

$$V_2^- = \frac{-j}{\sqrt{2}}V_{A2}^+ + \frac{1}{\sqrt{2}}V_{B2}^+ = \frac{-j}{\sqrt{2}}G_A V_{A1}^+ + \frac{1}{\sqrt{2}}G_B V_{B1}^+ \quad (2.2)$$

Where G_A and G_B is the gain of amplifiers respectively A and B and output voltage can be written briefly as

$$V_2^- = \frac{-j}{2}V_1^+(G_A + G_B) \quad (2.3)$$

S_{21} extracted from equation (2.3) which represents the gain of whole balanced amplifier can be written as

$$S_{21} = \frac{V_2^-}{V_1^+} = \frac{-j}{2}(G_A + G_B) \quad (2.4)$$

When amplifiers are identical in other words $G_A = G_B$ and $\Gamma_A = \Gamma_B$ (reflection coefficients are equal) [9]. This is a special case and figures $S_{11} = 0$ so that perfectly matched couplers are obtained in balanced amplifier design [9].

- **Feedback Amplification :**

Niclas, et al. [16] is mentioned that parasitic elements of active devices limit the bandwidth of amplifier. Feedback amplifier is developed to minimize these effects on extension bandwidth [16] and this topology was proposed in this paper.

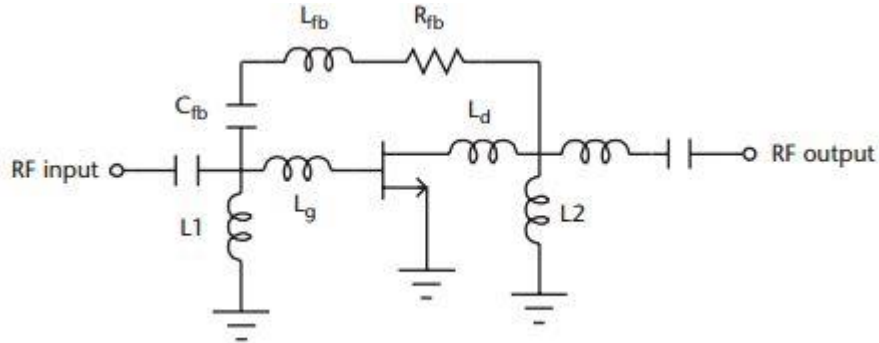

Figure 11 Feedback amplifier topology (given in [15])

L_{fb} , C_{fb} and R_{fb} are the elements of feedback topology which is shown in Fig. 11. L_{fb} can define the operating frequency with drain and gate lines inductance. Its adjustments provide flat gain while increasing frequency. Another component of feedback route is C_{fb} which eliminates DC biasing effects on gate and drain lines. Feedback resistance is obtained R_{fb} which decreases gain at lower frequencies and designates the gain and bandwidth of the amplifier [15]. Feedback resistor R_{fb} can also be used alone in hybrid topologies to obtain gain-flatness.

The last broadband amplification method is distributed amplification which is used in this thesis designed amplifier. It will be explained in next section.

2.3 Distributed Amplification

Thermionic valve circuit was described to obtain voltage amplification by Percival [17] and his invention is based on using an amplifying path to bypass cathode follower valve in wide frequencies. In other words, he described [17] that input circuit capacitance and resistance of the valve defines the bandwidth. Thereafter, Ginzton [18] named this new amplification technique (theory) as distributed amplification and defined basic principles of distributed amplification. The traveling-wave concept was followed in his design and a new technique was developed for

wide band amplifiers at both low frequencies and microwaves [18]. Fundamental idea of this configuration is that two artificial transmission lines are designed by absorbing tube capacitances [18]. Therefore, transmission lines overcome the challenge which capacitances of active device bound the bandwidth of amplifier.

In development process of distributed amplification techniques, BJTs and FETs are used for many studies in literature. Jutzi [19] designed 2 GHz bandwidth distributed amplifier with MESFETs and in this study characteristic impedances of lines are chosen as 50Ω . In this configuration, approximately 6 dB gain was obtained and noise figure was between 5 - 7 dB at nearly 2 GHz. Afterwards, a monolithic GaAs FET traveling-wave amplifier at 1-13 GHz operating frequency band was designed and manufactured [10]. Ayasli [10] showed that increase in active device (transistor) did not increase the gain also; gain performance got near zero with large number of stages on the contrary early conventional amplifiers theories. New insights have been provided to broadband microwave amplifier world with developed new transistors. Moreover, power added efficiency (PAE) and gain flatness have increased in distributed amplification with these new insights.

The basic configuration of conventional distributed amplifier with N identical FETs is shown in Fig. 12. At the same time, configuration in this figure works in a special case which is unilateral version ($C_{gd} = 0$) [9]. Their gate and drain poles are connected to separate terminated artificial transmission lines which have characteristic impedances respectively Z_g and Z_d [9]. Artificial transmission lines may be formed of both lumped elements and micro strip lines. Transmission lines absorb the input and output capacitances of transistor and the bandwidth of this configuration is determined by the transmission line.

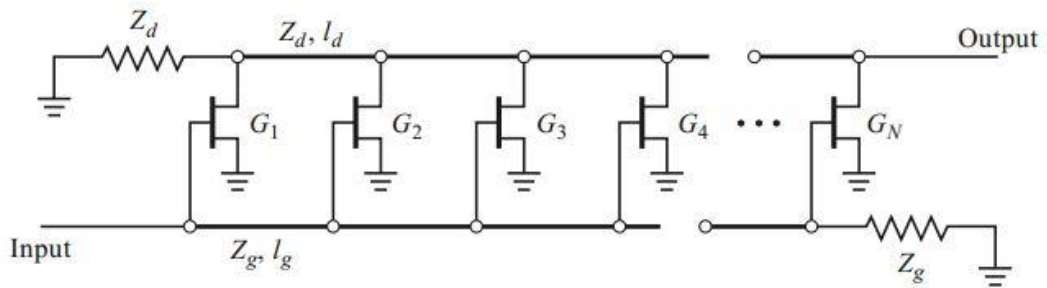

Figure 12 Basic diagram of N-stage distributed amplifier (given in [9])

DA equations and principles will be discussed in next chapter in detail. Moreover, using DA technique 1-3 GHz (L-S Band) will be designed with AWR microwave Office CAD tool and stages of design process will be explained. After that, simulation results and main parameters of the amplifier will be evaluated.

CHAPTER 3

ANALYSIS OF THE DISTRIBUTED AMPLIFIER

3.1 Principles of Distributed Amplifier

Distributed amplifier is known as one of the most common and well-established broadband amplifier techniques [20] owing to high wideband performance, low voltage standing wave ratio (VSWR) over operation frequency range, noise figure and low cost.

Cut off frequency is defined by inductance of artificial transmission lines and gate to source capacitor C_{gs} of the transistor [20]. If gate to source capacitor value is high, cut off frequency will be low.

The fundamental working principle of distributed amplifier is that intrinsic capacitances of transistor are absorbed with two identical inductive transmission lines. In Fig. 13, it is seen that these lines are parallel each other. R_g and R_d parameters are expressed the termination impedance of gate and drain lines, respectively.

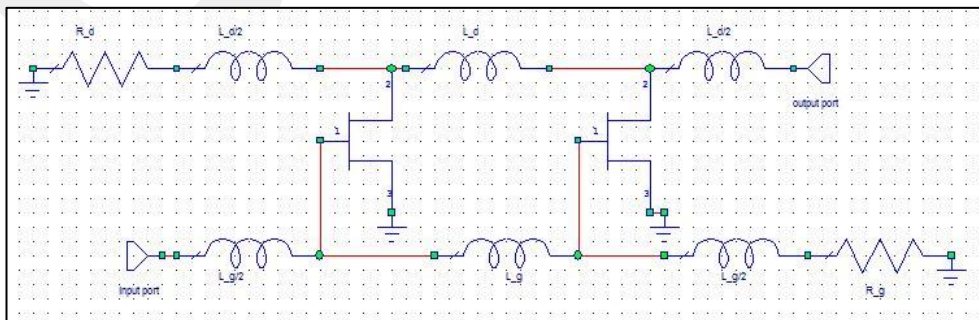

Figure 13 Simplified schematic of 2 – DA with lumped elements [21]

The basic concept of conventional distributed amplifier is paralleling number of ideally similar transistor with connected two artificial transmission lines. These lines have the constant characteristic impedances as Z_g for gate line and Z_d for drain line and they are matched with the characteristic impedance of whole circuit Z_0 . Their strategy is that the gate to source capacitance C_{gs} of the transistor regarded as input capacitance is a part of the transmission lines and cancelled with the inductive artificial lines. It is similar with for output capacitance. In shown Fig. 14, basic configuration of conventional distributed amplifier works as a RF input travelling from left to right and terminating with a resistance circuit.

Amplifying process in this configuration begins at first stage with a RF input going out from the gate of transistor and traveling from the left to right and at the end of line terminating in a resistance and biased circuit. Then, a portion of amplified signal at the drain of transistor wants to travel right and another portion of the signal wants to travel left. All other stages are similar with the first stage. It is considered in this working principle that transmission lines are adjusted signals at opposite direction cancelling each other at the interstage of the transistor. It is not perfectly matched yet reasonably close. Hence, backward waves are not considered.

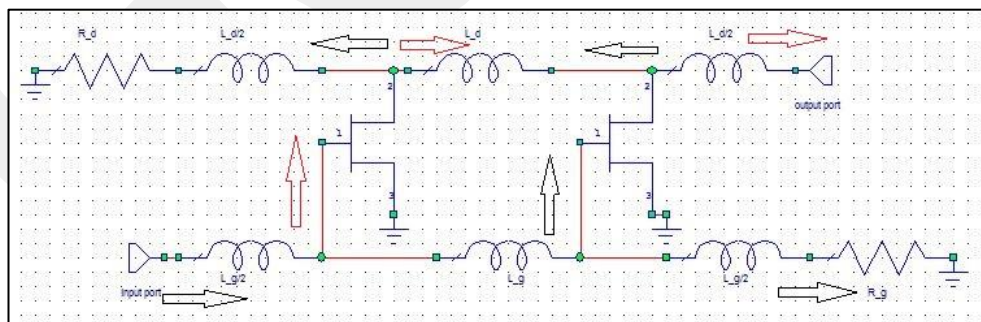

Figure 14 Basic concept of conventional distributed amplifier

3.2 Analytical Analysis of Distributed Amplifier

Pozar [9] analyzed N-stage conventional distributed amplifier theory analytically. Fig.15 shows equivalent circuit for unit stage of the gate line. Z_g is defined as characteristic impedance of the gate line and L_g expresses the whole gate line length, l_g means per unit length [9]. R_i is the input resistance of FET, according to Advanced Curtice-2 Die Model it is defined as gate to source resistance as well. Also, parasitic elements in this die model of ATF-54143 transistor are used in the thesis.

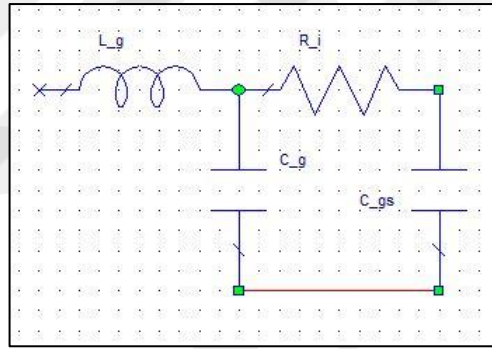

Figure 15 The equivalent circuit of a single unit cell of the gate line [9]

$$Z = j\omega L_g \quad (3.1)$$

$$Y = j\omega C_g + \frac{j\omega C_{gs} / l_g}{1 + j\omega R_i C_{gs}} \quad (3.2)$$

Impedance of the gate line and shunt admittance per unit length [9] is expressed with respectively equations (3.1) and (3.2).

Assuming loss neglected, characteristic impedance can be written as

$$Z_g = \sqrt{\frac{Z}{Y}} = \sqrt{\frac{L_g}{C_g + C_{gs}/l_g}} \quad (3.3)$$

When formulating of propagation constant, attenuation will be originated by resistive term by reason of attenuation.

$$\gamma_g = \alpha_g + j\beta_g = \sqrt{ZY} = \sqrt{j\omega L_g \left(j\omega C_g + \frac{\frac{j\omega C_{gs}}{l_g}}{1 + j\omega R_i C_{gs}} \right)} \quad (3.4)$$

If small loss is assumed, $\omega R_i C_{gs} \ll 1$ is obtained and above equation is arranged as

$$\begin{aligned} \gamma_g = \alpha_g + j\beta_g &\cong \sqrt{-\omega^2 L_g [C_g + C_{gs}(1 - j\omega R_i C_{gs})/l_g]} \\ &\cong \frac{\omega^2 R_i C_{gs}^2 Z_g}{2l_g} + j\omega \sqrt{L_g (C_g + C_{gs}/l_g)} \end{aligned} \quad (3.5)$$

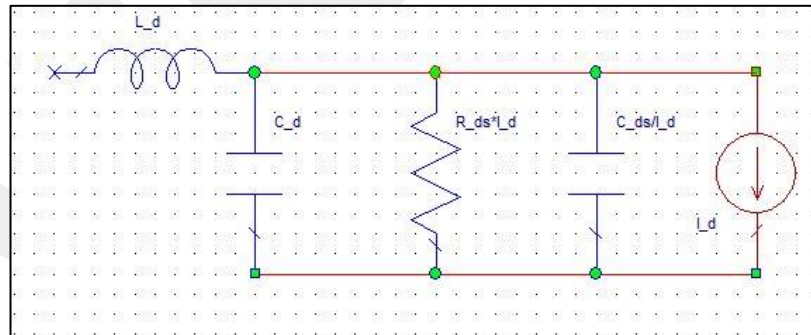

Figure 16 The equivalent circuit of a single unit cell of the drain line [9]

Fig.16 shows equivalent circuit for unit stage of the drain line which is similar with gate line, characteristic impedance of drain line and shunt admittance per unit length are calculated as

$$Z = j\omega L_d \quad (3.6)$$

$$Y = \frac{1}{R_{ds}l_d} + j\omega(C_d + C_{ds}/l_d) \quad (3.7)$$

$$Z_d = \sqrt{\frac{Z}{Y}} = \sqrt{\frac{L_d}{C_d + C_{ds}/d}} \quad (3.8)$$

Propagation constant of the drain line is expressed with some negligence as

$$\gamma_d = \alpha_d + j\beta_d = \sqrt{ZY} = \sqrt{j\omega L_d \left(\frac{1}{R_{ds}l_d} + j\omega(C_d + C_{ds}/l_d) \right)} \quad (3.9)$$

$$\cong \frac{Z_d}{2R_{ds}l_d} + j\omega\sqrt{L_d(C_d + C_{ds}/l_d)} \quad (3.10)$$

Phase differences are not considered in distributed amplification owing to $\beta_g l_g = \beta_d l_d$ condition [9, 10] and this is obtained thanks to equal transmission lines. It is assumed that drain and gate line impedances are approximately equal the characteristic impedance. Hence, it is written gain equation in a simple way.

$$G = \frac{P_{out}}{P_{in}} = \frac{g_m^2 Z_d Z_g (e^{-N\alpha_g l_g} - e^{-N\alpha_d l_d})^2}{4 (e^{-\alpha_g l_g} - e^{-\alpha_d l_d})^2} \quad (3.11)$$

Because of $Z_d = Z_g$ and, small divider part of equation (3.11) gain is written as

$$G = \frac{g_m^2 Z_d Z_g N^2}{4} \quad (3.12)$$

$$N_{opt} = \frac{\ln(a_g l_g / a_d l_d)}{a_g l_g - a_d l_d} \quad (3.13)$$

Number of stages depend on the losses in the amplifier gate and drain line, so when the number of transistors is in increase gain approaches to zero [9, 10]. Starting travel from the gate to drain input signal attenuated each line and amplified signal cannot come in the output at the last drain pole if the number of transistor approaches infinity [9, 10]. The most optimal number of transistors is calculated with equation (3.13).

3.3 About Transistors Used in Case Study

Avago Technologies ATF-54143 model transistor which has Low Noise Enhancement Mode Pseudomorphic High Electron Mobility Transistor (E-PHEMT) technology is used in the thesis for all analyses and designs. Operation frequency range of ATF-54143 is 450 MHz to 6 GHz. Common usage fields are low noise applications [22]. It is preferred since less noisy design is obtained.

It is biased with 3.6 V from drain and gate poles. Transistor operating conditions are chosen $V_{ds} = 3V$ and $I_{ds} = 60 mA$ for case studies. At 2 GHz frequency, 3V and 60 mA noise figure 0.5 dB, associated gain is 16.6 are stated in datasheet of ATF-54143 [22]. Also, advanced curtime-2 die model and scattering parameters according to chosen bias condition are presented at appendices section. Moreover, transistor C_{gs} gate to source capacitance value is 1.73 pF and C_{ds} drain to source capacitance value is 0.27 pF. These intrinsic capacitances of transistor is defined inductive artificial transmission line parameters according to cut off frequency in distributed amplifier design procedures.

3.4 Stability Analysis

Stability is one of the most important requirements for designing amplifier. It is analyzed to prevent low-frequency oscillations because of internal, external and thermal feedback [23]. Conditionally stable and unstable active devices have negative effects on amplifier such as gain performance, noise figure and efficiency. To overcome these problems, Rollet's condition and auxiliary condition is applied with using equations (1.11) and (1.12). In this design, stability analysis is done by help of CAD tool.

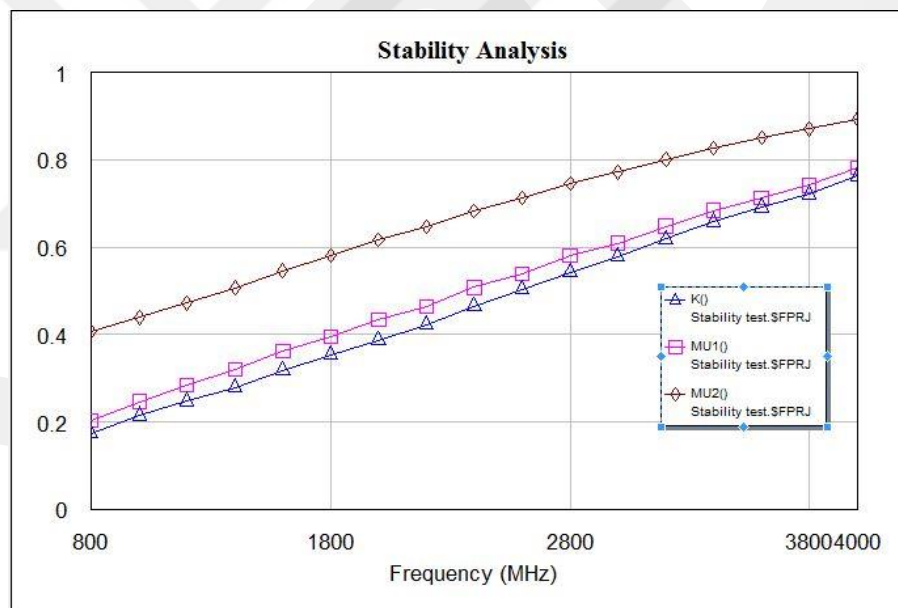

Figure 17 Stability analysis of ATF-54143 at operating frequency range for $V_{ds}=3V$ and $I_{ds}=60\text{ mA}$

Fig. 17 shows that transistor is not unconditionally stable at determined conditions and operating frequency of so stability circuit is added to provide unconditionally stability for the designed amplifier. This circuit generally comprises of a resistor and a capacitor like Fig. 18; so that electrical behavior of transistor is improved as unconditionally stable.

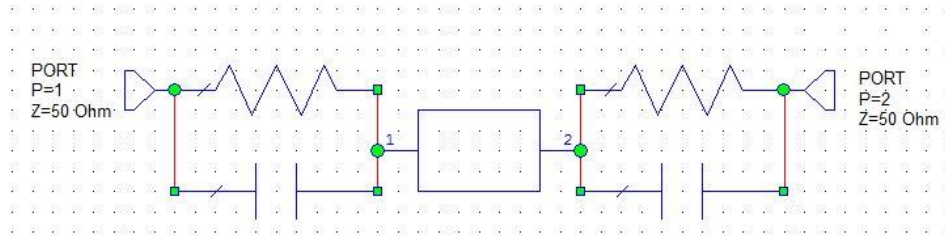

Figure 18 Stability circuit schematic

After the connection of stability circuit which is represented in Fig.18 to active device, unconditionally stability requirements are fulfilled. According to the results of Stability Analysis graph, stability circuit is designed and optimized. Stability Check graph is obtained with using 22 Ω resistors and 2 pF capacitors. All stability parameters are bigger than 1 so, transistor is unconditionally stable.

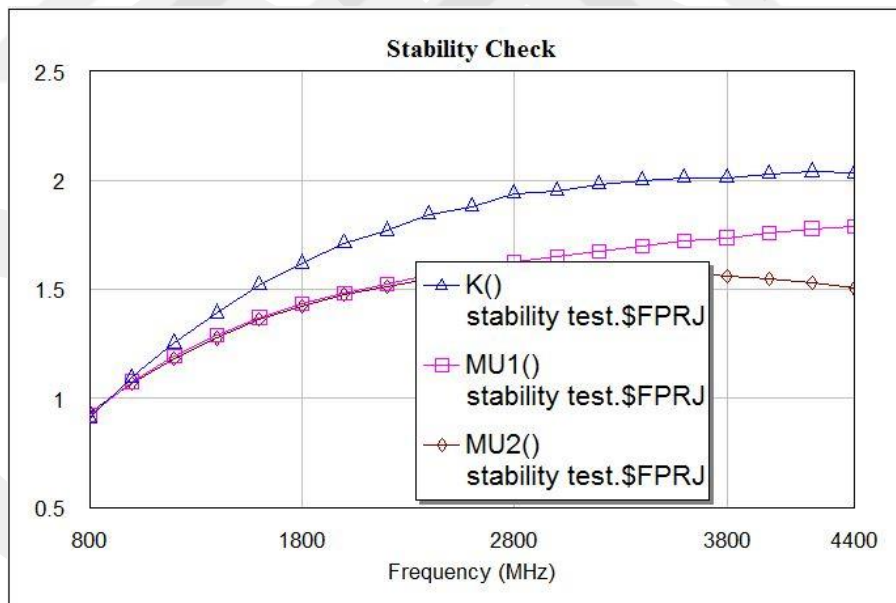

Figure 19 Stability analysis after the connecting stability circuit

Stability circuit is provided unconditionally stability at amplifier operating frequency range which is 1-3 GHz and as seen in Fig. 19.

3.5 Bias Circuit of Used Transistor

In the thesis, passive biased circuit is designed with 3.6V supply. $V_{ds}=3V$ and $I_{ds}=60$ mA biasing condition is made up. Fig. 16 shows bias circuit schematic of the design amplifier in case study. In this bias circuit, $V_{ds}=3V$ and $I_{ds}=62.4$ mA is measured from analyzing on AWR Microwave Office.

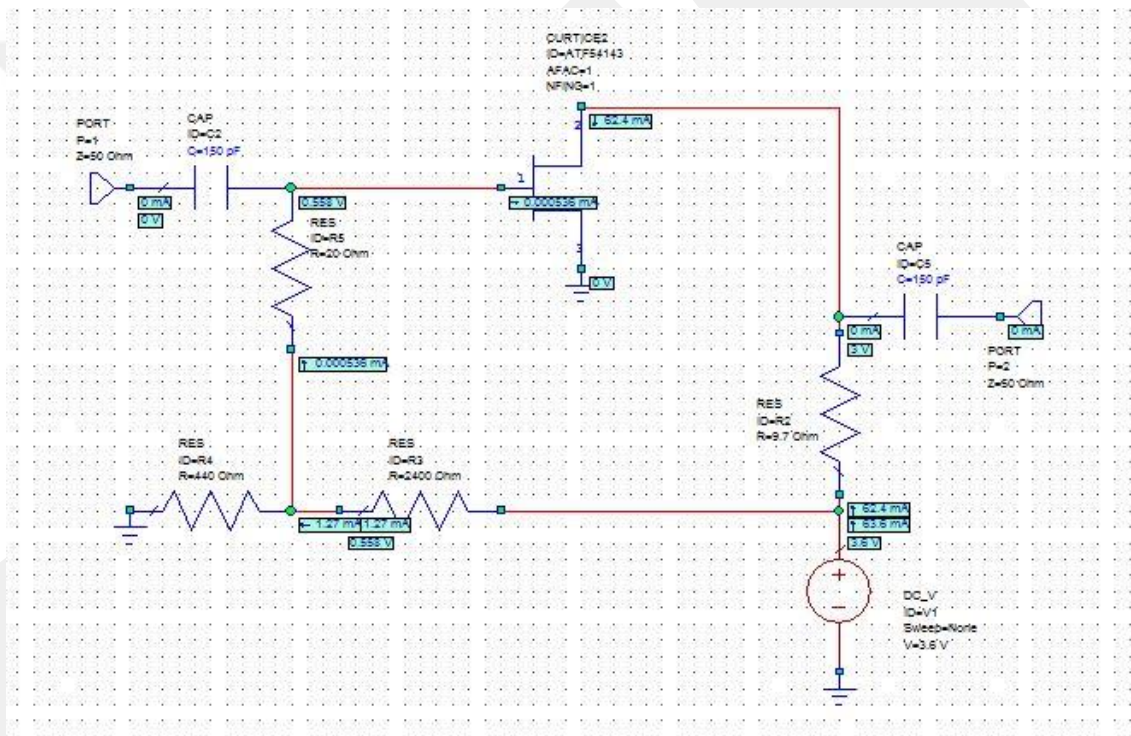

Figure 20 Bias circuit schematic

For microwave amplifiers, there are several configurations to design bias network and voltage divider bias technique is used to design bias circuit and simulation results are also given Fig.20. Moreover, ATF-54143 is defined with CURTICE2 Model and its die model parameters are given at APPENDIX A.

3.6 Input and Output Matching Circuits

Impedance matching is a way to transfer maximum power from the source to the load. Impedance matching network are designed by conjugate matching reflection coefficients of source and load with input and output reflection coefficients of the active device [3, 9] to obtain the maximum gain stable single stage transistor amplifier. To calculate these reflection coefficients for simultaneous conjugate match some formulas are defined as:

$$\Gamma_s = \frac{B_1 \pm \sqrt{B_1^2 - 4|C_1|^2}}{2C_1} \quad (3.14)$$

$$\Gamma_L = \frac{B_2 \pm \sqrt{B_2^2 - 4|C_2|^2}}{2C_2} \quad (3.15)$$

Above equations express reflection coefficient of source and load and variables used in (3.14) and (3.15) is found with following formulas.

$$B_1 = 1 + |S_{11}|^2 - |S_{22}|^2 - |\Delta|^2 \quad (3.16)$$

$$B_2 = 1 + |S_{22}|^2 - |S_{11}|^2 - |\Delta|^2 \quad (3.17)$$

$$C_1 = S_{11} - \Delta S_{22}^* \quad (3.18)$$

$$C_2 = S_{22} - \Delta S_{11}^* \quad (3.19)$$

Γ_{in} and Γ_{out} are input and output matched circuit reflection coefficients of the transistor. And they are equal conjugate of the source and load reflection coefficients as defined with below equations.

$$\Gamma_{in} = \Gamma_S^* \quad \text{and} \quad \Gamma_{out} = \Gamma_L^* \quad (3.20)$$

Conjugate matching approach is the optimum matching technique for narrowband single stage transistor amplifier to transfer maximum power from source to load. However, matching networks may not cover whole frequency band for broadband amplifiers. If the impedances are close to each other, center frequency can be chosen by using equation (3.21) and then matching circuit elements can be optimized to increase available gain of amplifier.

It is required that matching network covers whole bandwidth with minimum reflection coefficient [23], and this is a problem to solve. By Bode-Fano criterion, to approach optimum matching network requirements are defined [23]. According to that criterion, center frequency of lossless matching network versions [23] is calculated as:

$$f_0 = \sqrt{f_L f_H} \quad (3.21)$$

f_0 is the center frequency between high and low cut off frequencies. This equation is simplified from

$$w_0 = \sqrt{w_L w_H} \quad (3.22)$$

It is required that matching network covers whole bandwidth with minimum reflection coefficient [23], and this is a problem to solve. By Bode-Fano criterion, to approach optimum matching network requirements are defined [23].

In the thesis, matching networks are design with CAD tools with bandpass filtering and bandpass impedance matching methods. By using (3.21) and (3.22) center

frequency is calculated with 1 GHz low frequency and 3 GHz high frequency. As a result center frequency is found approximately 1.7 GHz. For 1-3 GHz frequency range center frequency is approximately 1.7 GHz yet, matching circuits are designed center frequency based on 2 GHz since gain performance is higher at low frequencies than at high frequencies because of transistor characteristic. Hence, center frequency is chosen closer to high cut off frequency.

Frequency	Input Impedance	Output Impedance
1 GHz	7.764 - j49.854	8.371 - j1.979
1.25 GHz	5.445 - j39.617	8.192 - j1.801
1.5 GHz	4.175 - j32.610	8.051 - j1.665
1.75 GHz	3.407 - j27.487	7.940 - j1.556
2 GHz	2.908 - j23.558	7.854 - j1.468
2.25 GHz	2.566 - j20.430	7.786 - j1.397
2.5 GHz	2.323 - j17.866	7.732 - j1.341
2.75 GHz	2.144 - j15.715	7.689 - j1.295
3 GHz	2.010 - j13.873	7.653 - j1.260

Table 2 Input and output impedances of biased circuit for impedance matching circuits

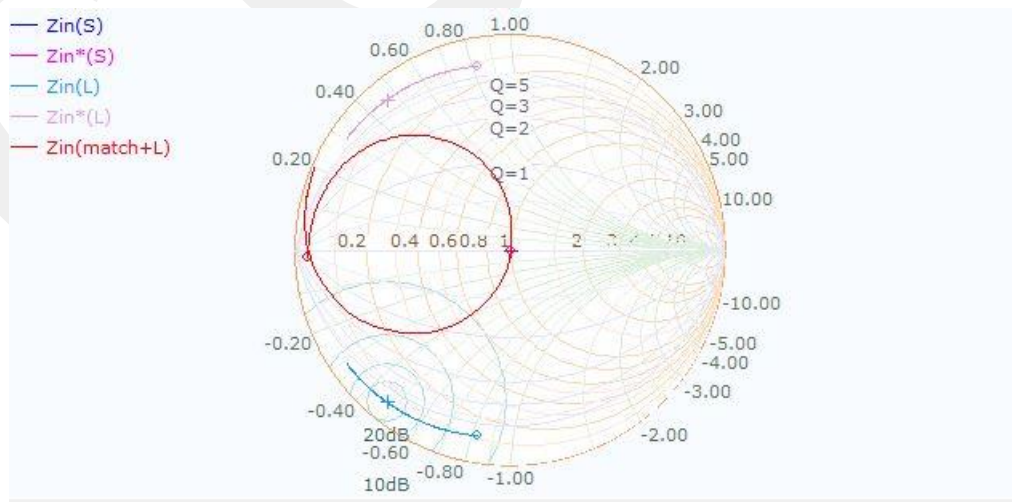

Figure 21 Input matching on Smith Chart

In Fig. 21 and Fig. 22 shows input and output matching studies on Smith Chart.

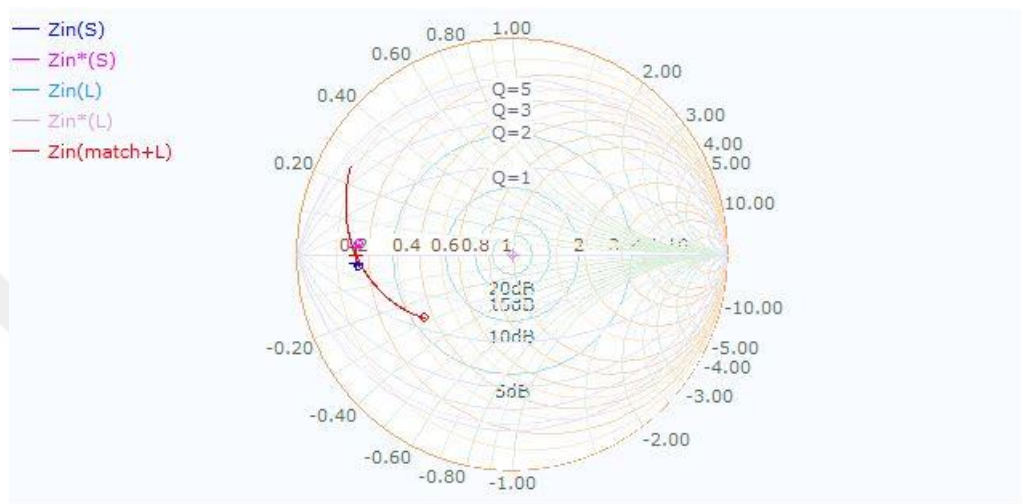

Figure 22 Output matching on Smith Chart

Fig. 23 represents input and output matching circuits for center frequency 2 GHz respectively. The left schematic shows the input matching circuit and the right schematic shows the output matching circuit.



Figure 23 Input and output impedance matching circuits (left -input matching, right -output matching)

CHAPTER 4

DESIGN OF DISTRIBUTED AMPLIFIER

4.1 Design and Simulation Results of Conventional Single Stage Distributed Amplifier

In previous chapter, it is mentioned that the significant point of the distributed amplification is absorbing internal parasitic capacitances at the transistor [25]. There are two artificial transmission lines are required to realize the main principle of distributed amplification. Also, input and output capacitances of the transistor with gate and drain transmission lines are matched to characteristic impedance with following equations.

$$f_c \cong \frac{1}{\pi\sqrt{LC}} \quad (3.23)$$

$$Z_0 = \sqrt{L/C} \quad (3.24)$$

When cut off frequency is defined, inductor value of the transmission line can be calculated by using equation (3.23). After that, according to characteristic impedance by using equation (3.24) capacitance value is found and T type or L type artificial line can be designed [25]. T type and L type transmission lines are designed for the gate in this single stage conventional distributed amplifier. Therefore, transistor is included as a part of 50 Ω system with inductive artificial transmission lines. Thanks to these principles of distributed amplification operation frequency band is increased for broadband amplifiers.

Calculations for Conventional SSDA:

DA configuration of ATF-54143 transmission line has 50 Ω characteristic impedance cut off frequency can be written as [23]

$$f_c = \frac{1}{\pi Z_0 C_{gs}} \quad (3.25)$$

According to principles of distributed amplification concept cut off frequency is determined 3 GHz and by using equation (3.23)

$$f_c \cong \frac{1}{\pi \sqrt{LC}} \cong 3 \text{ GHz} \cong 3 \times 10^9 \text{ Hz}$$

C represents C_{gs} (gate to source) parameter of transistor and its value is 1.73 pF.

$$3 \times 10^9 \cong \frac{1}{\pi \sqrt{L \times 1.73 \times 10^{-12}}}$$

$$9 \times 10^{18} \cong \frac{1}{\pi^2 \times L \times 1.73 \times 10^{-12}}$$

$$L = \frac{10^{-6}}{9 \times 1.73 \times \pi^2} = 6.50 \times 10^{-9} \text{ H}$$

Inductor value of artificial transmission lines is found 6.5 nH from calculations. After that, L/2 value is found as 3.25 nH.

Capacitance value which is used in T type and L type transmission lines is calculated to provide matching with system characteristic impedance as 50 Ω by following equation (3.24).

$$50 = \sqrt{6.5 \text{ nH}/C}$$

$$2500 = \frac{6.5 \times 10^{-9}}{C}$$

$$C = \frac{6.5 \times 10^{-11}}{25} = 2.6 \times 10^{-12}$$

Capacitance value of matching part is calculated as 2.6 pF.

Artificial transmission lines behavior is accepted like low pass filter characteristic [25] and found with calculation part. Their configuration is shown in Fig. 25.

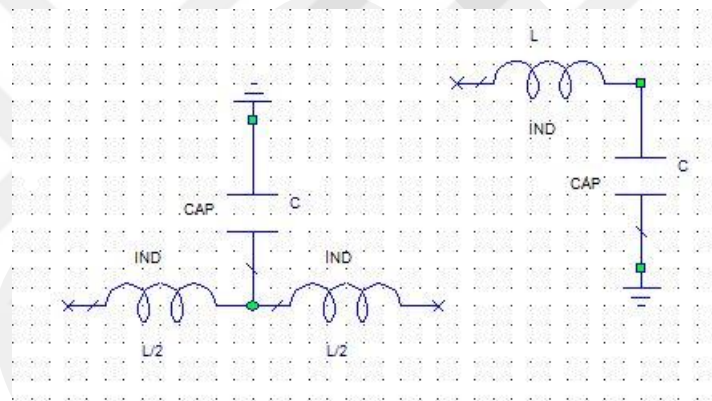

Figure 24 Basic schematics of T type and L type artificial transmission lines [25]

According to calculations and schematics in Fig. 24 gate and drain artificial transmission lines are designed. After that, gate line is terminated with resistor to provide decrease in gain at low frequencies. The reason is that gain performance decreases at high frequencies while increases at low frequencies because of transistor characteristic [25]. In distributed amplification, this technique is used to achieve gain flatness.

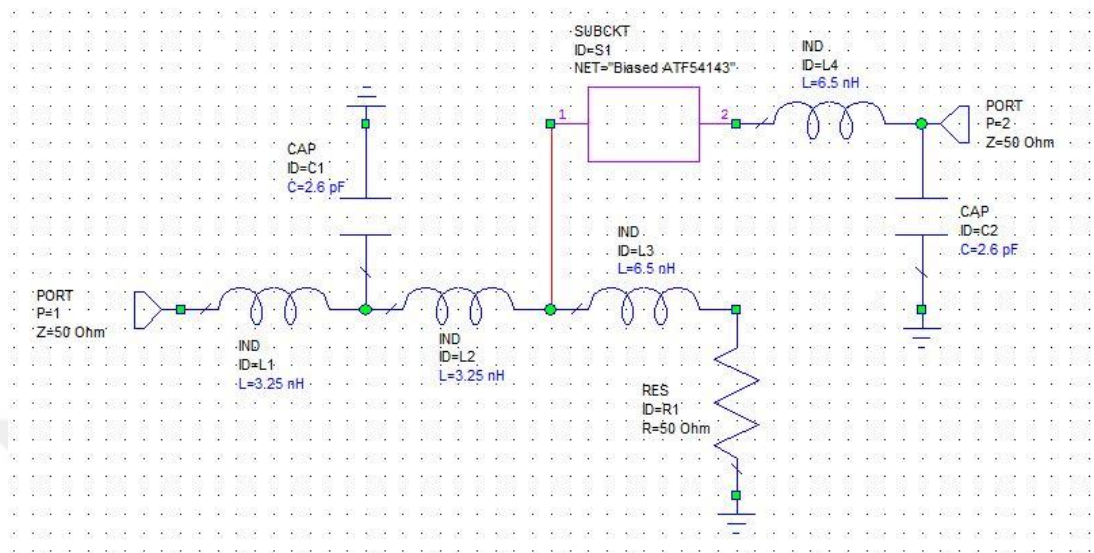

Figure 25 Conventional single stage distributed amplifier schematic

As seen in Fig. 25, gate and drain artificial transmission lines are integrated with biased active device according to results of calculations for conventional distributed amplifier. Also, gate artificial transmission line is terminated with resistance to decrease gain performance at low frequencies. Simulation of available gain is shown in Fig. 26. At design frequency range, gain is changeable between approximately 14.3 and almost 8.9 dB. At the end of operation frequency band available gain is dramatically decreased.

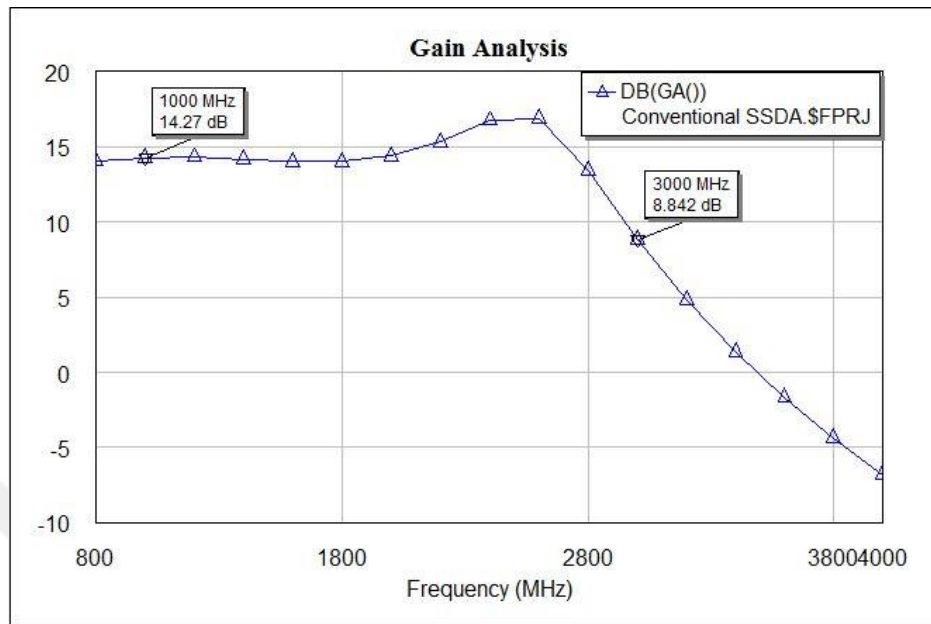

Figure 26 Available gain single stage distributed amplifier

Single stage distributed amplifier gain performance is affected from drawn equal transmission lines for gate and drain port of transistor and selected cut off frequency to obtain gain flatness at 1-3 GHz operation frequency band. Moreover, cut off frequency is selected as the end of frequency band 3 GHz and this leads to dramatic decrease in available gain so, in next section cut off frequency is moved to right to prevent dramatic decrease in gain at the end of frequencies.

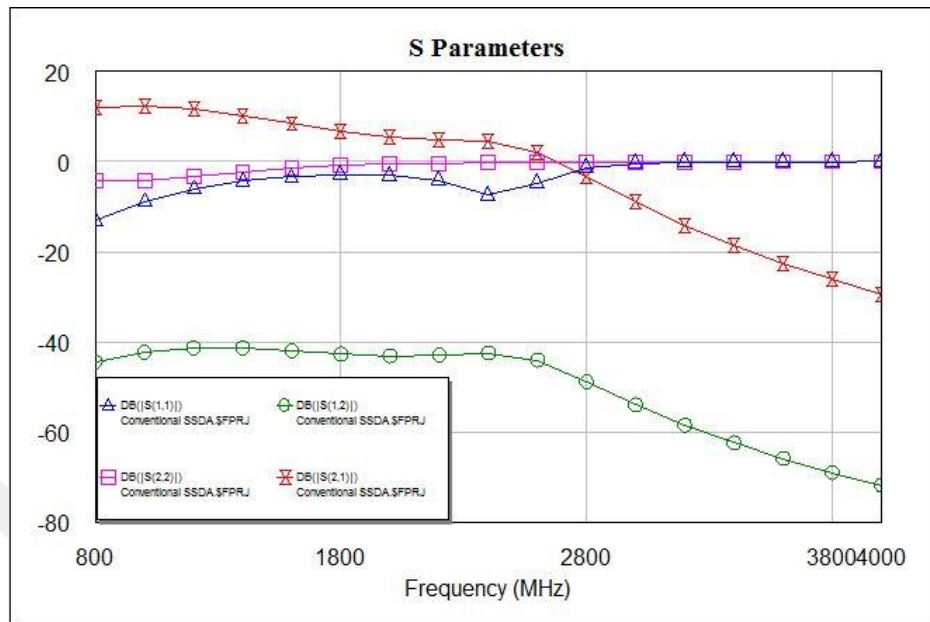

Figure 27 S parameters in logarithmic magnitude (in dB) of conventional SSDA

S parameters in logarithmic magnitude gives information about input return loss, output return loss and gain. In Fig. 27, S parameters simulation is shown. Input return loss value is almost -8.9 dB at the beginning of frequency band and approximately -0.5 dB at the end of the frequency band as seen in Fig. 27. If input and output return loss value is low, losses are low in amplifier. Output return loss line is starting from -4 dB at 1 GHz and it is in increase almost to -0.0.7 dB at 3GHz.

According to, gain performance simulations of drawn conventional single stage distributed amplifier schematic conjugate matched circuits are integrated to investigate gain performances. Impedance matching circuit consists of conjugate matched to input reflection coefficient of transistor as regards center frequency of bandwidth similar with narrowband amplification impedance matching technique. This analysis is followed for conventional distributed amplifier as a different point of view.

Frequency	Input Impedance	Output Impedance
1 GHz	7.764 - j49.854	8.371 - j1.979
1.5 GHz	4.175 - j32.610	8.051 - j1.665
2 GHz	2.908 - j23.558	7.854 - j1.468
2.5 GHz	2.323 - j17.866	7.732 - j1.341
3 GHz	2.010 - j13.873	7.653 - j1.260

Table 3 Input and output impedances of biased circuit at 1-3 GHz

In Fig. 28 and Fig. 29, input and output impedance matching studies on Smith Chart is shown respectively according to Table 3 and center frequency is calculated by using equation (3.21) and selected as 2 GHz. The reason is that gain performance is higher at low frequencies then at high frequencies so center frequency is closed to cut off frequency of the operation frequency band.

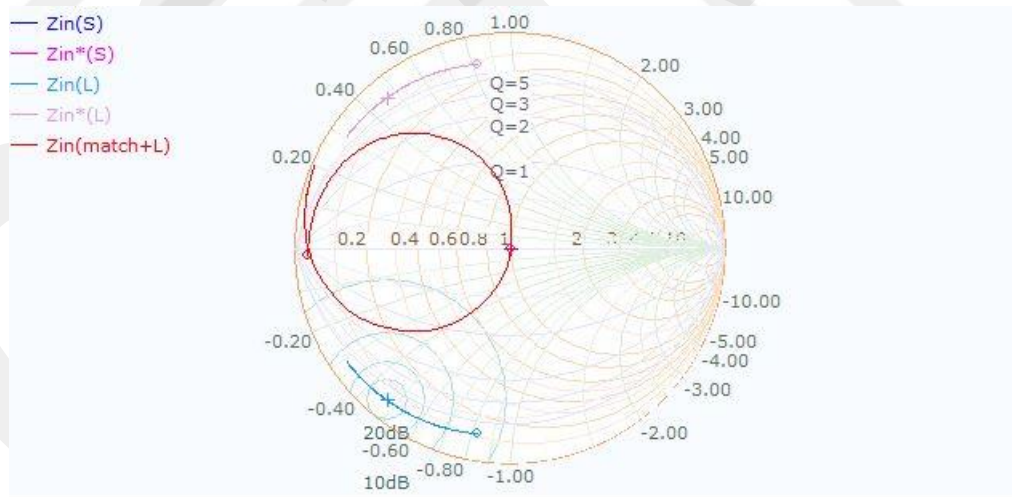

Figure 28 Input matching on Smith Chart

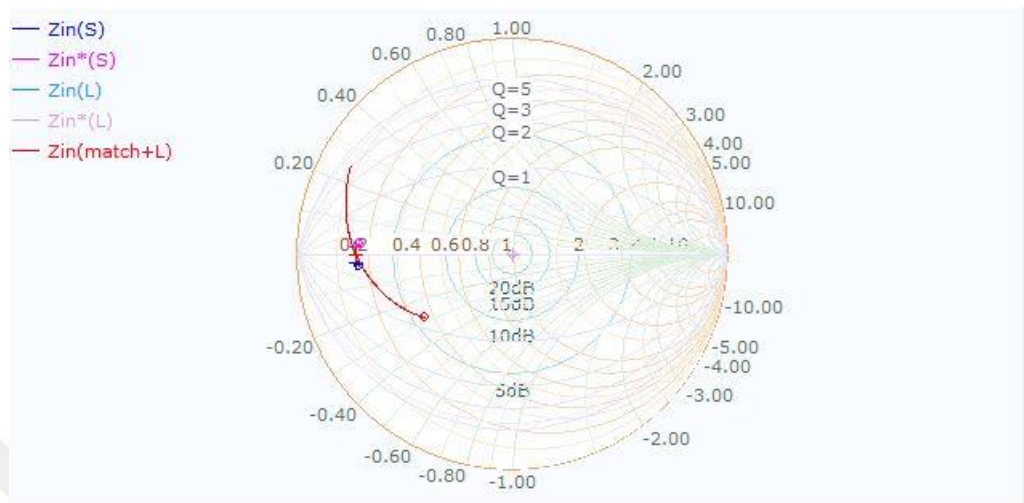

Figure 29 Output matching on Smith Chart

Fig. 30 represents input and output matching circuits which are integrated conventional single stage distributed amplifier to investigate impedance matching effects.



Figure 30 Input and output matching circuits of conventional SSDA

After drawing input and output matching circuits, they are integrated to biased ATF-54143 and conventional distributed amplification principles are followed. Impedance matched SSDA amplifier circuit is obtained and it is shown in Fig. 31.

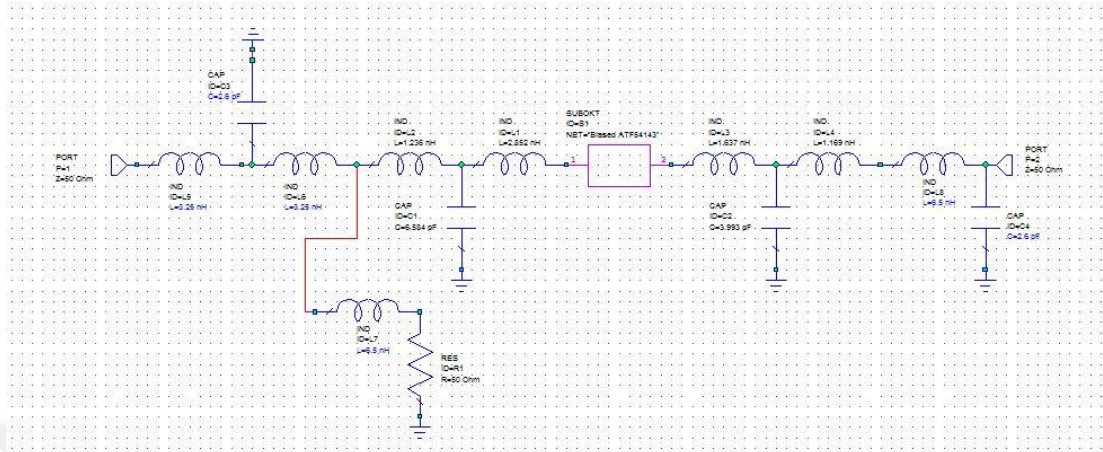

Figure 31 Schematic of impedance matched conventional SSDA

Thereafter, gain which is analyzed at 2.2 GHz frequency is dramatically in decrease. Impedance matched circuit provide high gain from near 1.5 GHz to approximately 2.2 GHz but flatness is so weak. Also, gain performance is so decreased at least -11 dB at the end of frequency band. Simultaneously conjugate impedance matching technique has negative effects of gain performance of distributed amplifier so, optimization studies are done on conventional single stage distributed amplifier by following only distributed amplification principles.

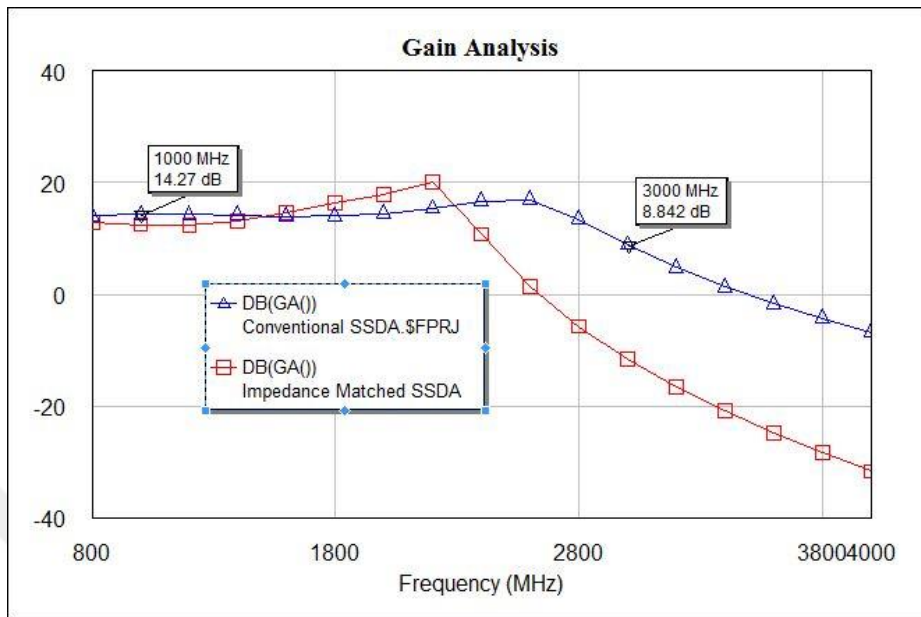

Figure 32 Available gains of SSDA and impedance matched SSDA

It is mentioned before section 3.4 Stability Analysis; stability of conventional SSDA is controlled and is observed in Fig. 33. K parameter is in Rollet's condition, and B1 represents auxiliary condition to analyze unconditional stability. Other parameters of stability analysis are MU1 and MU2 which represent μ tests for source and load ports respectively.

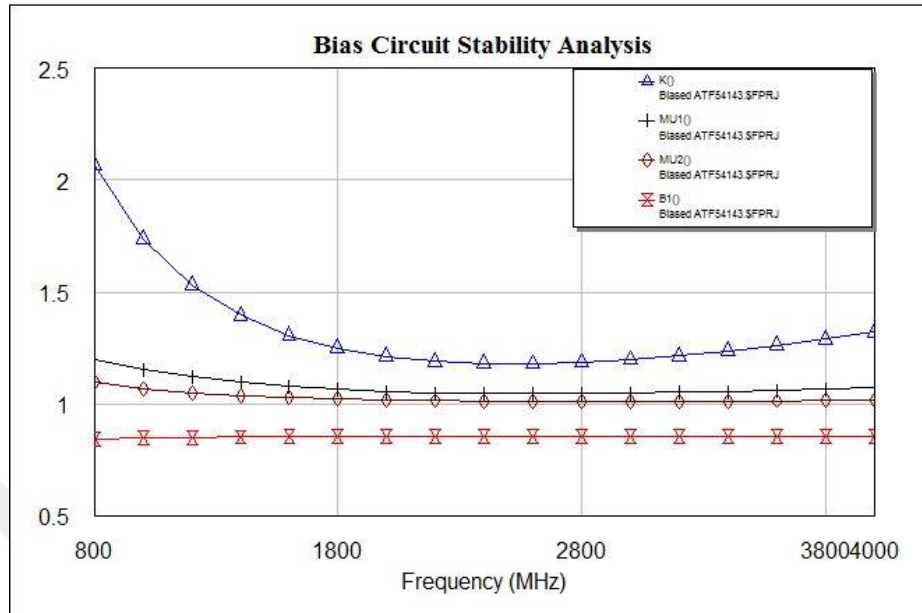

Figure 33 Stability control of conventional single stage distributed amplifier

In Fig. 25, amplifier is designed with reference to equal artificial lines, and so inductors for gate and drain lines are chosen same. However, drain to source C_{ds} capacitance is very low in comparison with gate to source capacitance so, inductor value changed for drain line. Cut off frequency is increased and moved to right of frequency band; because gain performance of the first one has dramatic decrease about 3 GHz.

4.2 Proposed Design of Single Stage Distributed Amplifier

As results of analysis single stage distributed amplifier design, optimization is applied to obtain fair flat gain performance for conventional distributed amplifier design at 1-3 GHz frequency band. Optimization process is begun with calculations for new cut off frequency. After that, according to drain to source capacitance drain artificial transmission line is drawn again so that not only equal but also identical artificial transmission line is drawn based on characteristic impedance 50Ω .

Calculations for Optimized SSDA:

According to principles of distributed amplification concept cut off frequency is determined 3 GHz and by using equation (3.23)

$$f_c \cong \frac{1}{\pi\sqrt{LC}} \cong 3.2 \text{ GHz} \cong 3.2 \times 10^9 \text{ Hz}$$

C represents C_{gs} (gate to source) parameter of transistor and its value is 1.73 pF.

$$3.2 \times 10^9 \cong \frac{1}{\pi\sqrt{L \times 1.73 \times 10^{-12}}}$$

$$10.24 \times 10^{18} \cong \frac{1}{\pi^2 \times L \times 1.73 \times 10^{-12}}$$

$$L = \frac{10^{-6}}{10.24 \times 1.73 \times \pi^2} \cong 5.72 \times 10^{-9} \text{ H}$$

Inductor value of artificial transmission line for gate line is found 5.72 nH from calculations. After that, L/2 value is found as 2.85 nH.

Capacitance value which is used in T type and L type transmission lines is calculated to provide matching with system characteristic impedance as 50 Ω by following equation (3.24).

$$50 = \sqrt{5.72 \text{ nH}/C}$$

$$2500 = \frac{5.72 \times 10^{-9}}{C}$$

$$C = \frac{5.72 \times 10^{-11}}{25} \cong 2.3 \times 10^{-12}$$

Capacitance value of gate line is calculated as 2.3 pF.

C represents C_{ds} (gate to source) parameter of transistor and its value is 0.27 pF.

$$f_c \cong \frac{1}{\pi\sqrt{LC}} \cong 3.2 \text{ GHz} \cong 3.2 \times 10^9 \text{ Hz}$$

$$3.2 \times 10^9 \cong \frac{1}{\pi\sqrt{L \times 0.27 \times 10^{-12}}}$$

$$10.24 \times 10^{18} \cong \frac{1}{\pi^2 \times L \times 0.27 \times 10^{-12}}$$

$$L = \frac{10^{-6}}{10.24 \times 0.27 \times \pi^2} \cong 36.64 \times 10^{-9} \text{ H}$$

Inductor value of artificial transmission line for drain line is found 36.64 nH from calculations. After that, L/2 value is found as 18.3 nH. Capacitance value which is used in T type and L type transmission lines is calculated to provide matching with system characteristic impedance as 50 Ω by following equation (3.24).

$$50 = \sqrt{36.64 \text{ nH}/C}$$

$$2500 = \frac{36.64 \times 10^{-9}}{C}$$

$$C = \frac{36.64 \times 10^{-11}}{25} \cong 0.146 \times 10^{-12}$$

Capacitance value of drain line is calculated as 0.146 pF.

According to calculations, conventional single stage distributed amplifier is optimized and it is shown in Fig. 34.

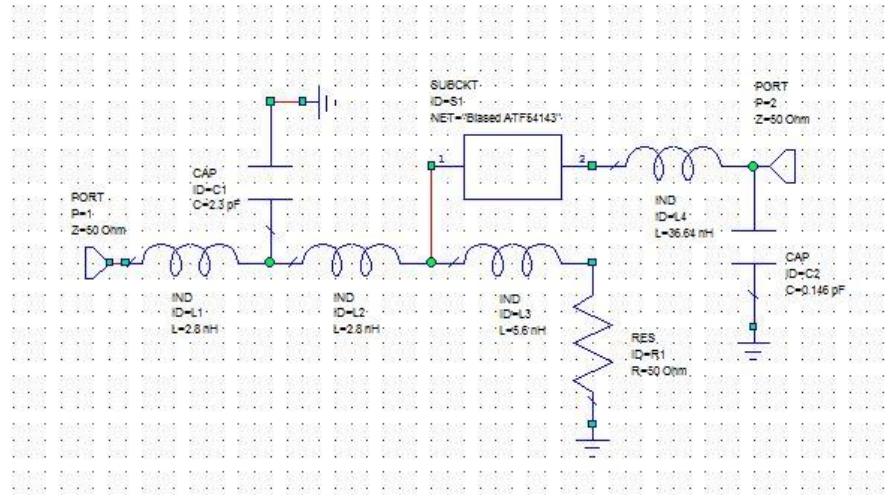

Figure 34 Optimized single stage distributed amplifier

Gain analysis of optimized single stage distributed amplifier is shown in Fig. 35. Available gain of optimized amplifier circuit is approximately 14 dB at the beginning of frequency band and almost 14.7 dB at the end of frequency band. Gain is increased in comparison with first amplifier and also flatness is obtained in the selected operation frequency band.

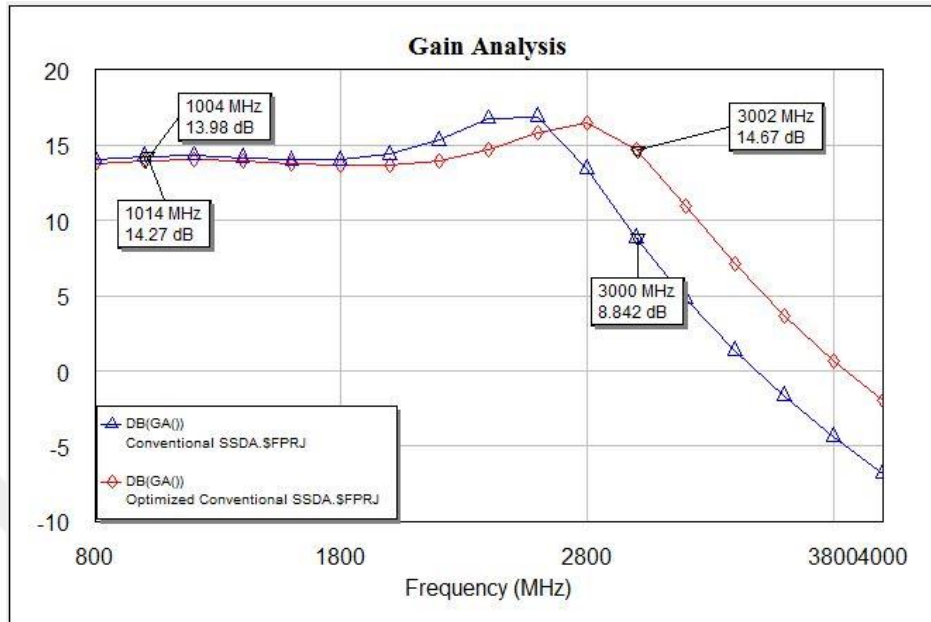

Figure 35 Gain performance of optimized SSSA and conventional SSSA amplifier designs

Fig. 35 shows gain values of optimized SSSA and as seen in graph above, gain is flat and increased to 13.7+1 dB for 1-3 GHz frequency band.

One of the important requirements is unconditional stability is provided in optimized design. Fig. 36 includes stability analysis of proposed distributed amplifier.

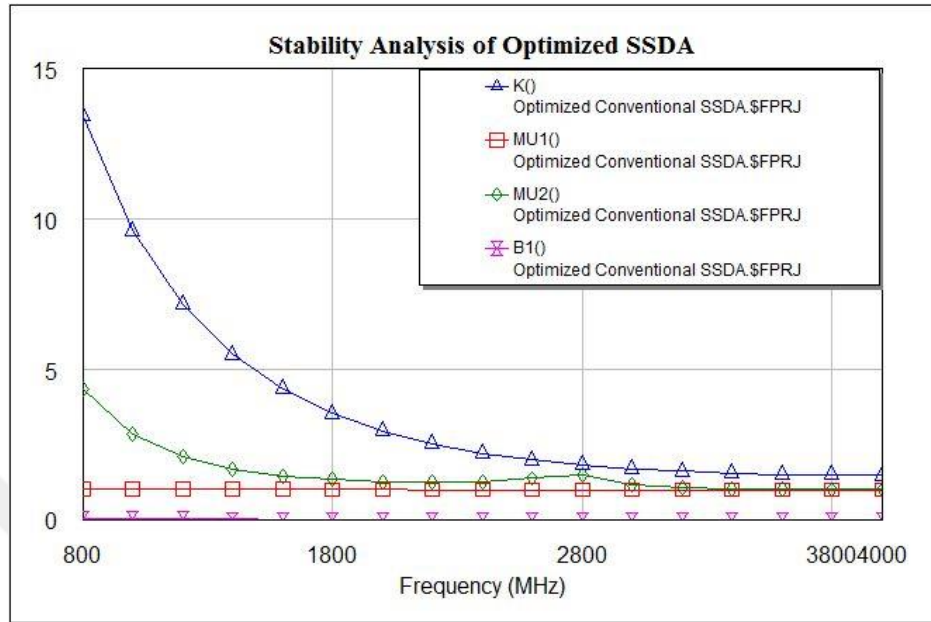

Figure 36 Stability Analysis of optimized single stage distributed amplifier

Parameters which are in Fig. 36 analyze unconditional stability for optimized amplifier circuit. K parameter is in Rollet's condition, and B1 represents auxiliary condition to analyze unconditional stability. Other parameters of stability analysis are MU1 and MU2 which represent μ tests for source and load ports respectively.

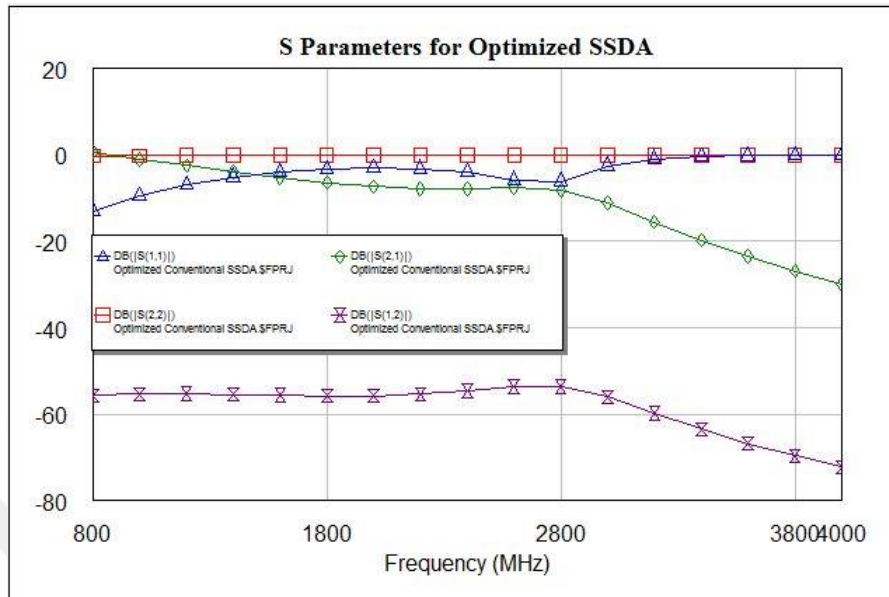

Figure 37 S parameters (in dB) of optimized single stage distributed amplifier

S parameters in logarithmic magnitude gives information about input return loss, output return loss and gain. In Fig. 28, S parameters simulation is shown. Input return loss value is -9.4 dB at the beginning of frequency band and approximately -2.5 dB at the end of the frequency band and minimum value is -9.4 dB near 1 GHz as seen in Fig. 28. If input and output return loss value is low, losses are low in amplifier. Output return loss line is starting from -0.14 dB at 1 GHz and it is in increase to -0.11 dB at 3GHz.

Available gain is measured by increasing the number of stages. As a result, as the stages increase, gain performance gets worse. When calculating optimum number of transistor, equation (3.5) is used and result equals to 24 because of drain line attenuation is bigger than the gate line attenuation.

4.3 2 – CASCADED Single Stage Distributed Amplifier

Cascaded Single Stage Distributed Amplifier (CSSDA) is based on conventional distributed amplifier or traveling wave amplifier theory. Input signal goes into transmission line and after amplified travel to the gate of second transistor. High gain and gain flatness in bandwidth can be obtained with different configurations of CSSDA.

Conventional distributed amplifier gain value is restricted because of optimum stages of transistors. Hence, to obtain high gain and solve conventional distributed amplifier configuration problems a new topology is developed as cascaded gain stages [27]. Series number of FETs are connected cascaded and their separate terminations of gate and drain line brings a new concept to broadband amplification world [20]. Internal characteristic impedance is used the inner stages termination. Other side, gate and drain stages are terminated with characteristic impedances of transmission lines [20]. Also, every stage of the amplifier behaves like a T-type amplifier [20].

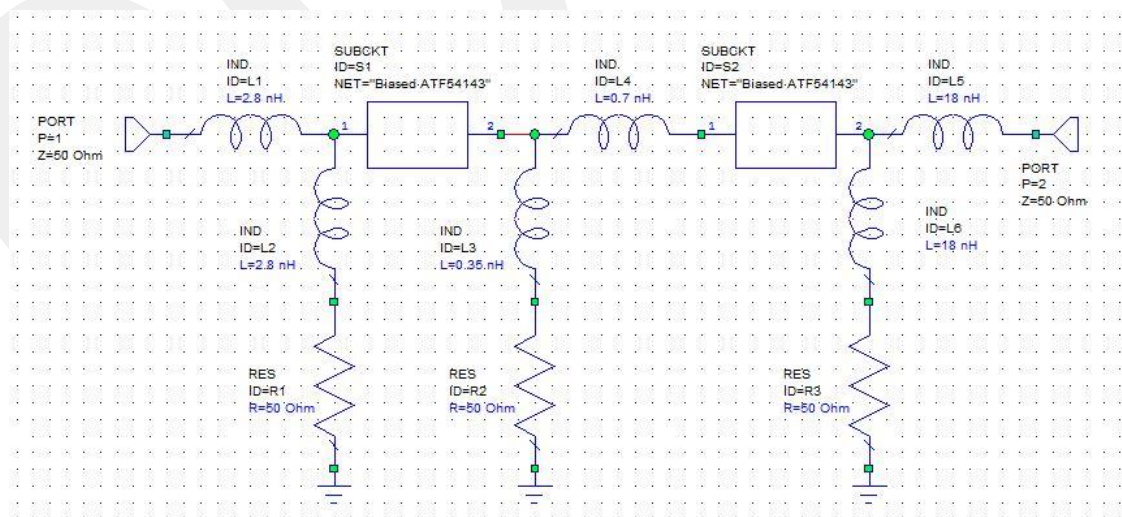

Figure 38 Designed 2-CSSDA schematic

CSSDA consists of two p-HEMT ATF-54143 in series with transmission lines which is terminated with system characteristic impedances of FETs. Also, another successful technique is reactive termination [24] which works as matching characteristic impedances of the gate and drain pole of the transistor [24]. In this circuit design calculations for optimized SSDA are used and components are determined according to results of these calculations. For interstage part, bandpass structure is followed to obtain flatness and to prevent dramatic decrease at the end of frequency range. L component is determined as 0.7 nH and L/2 component is calculated for 0.35. Capacitances are not integrated in order to absorb gate to source and drain to source capacitances. Therefore, 2-CSSDA schematic is drawn as seen in Fig. 38.

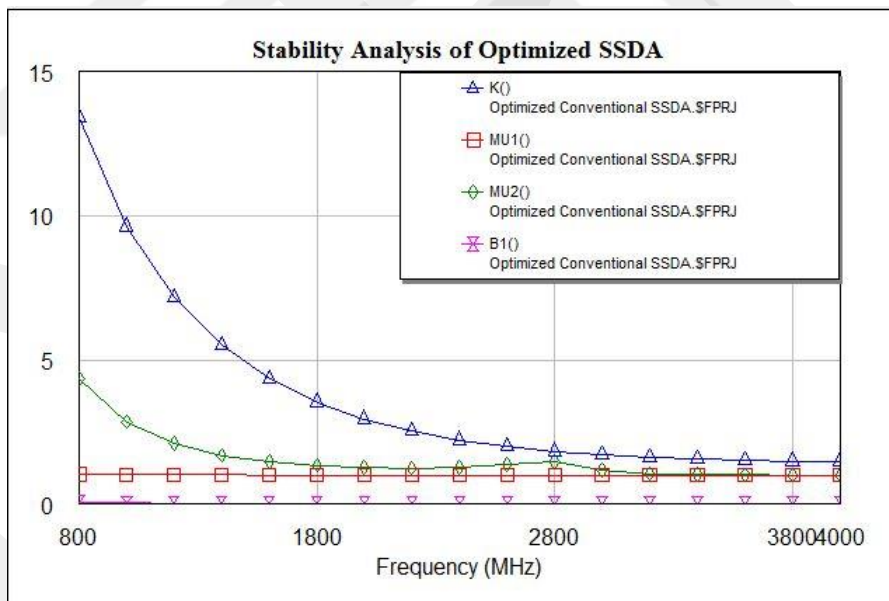

Figure 39 Stability analysis of 2-CSSDA

Unconditionally stability is provided in this configuration and Fig. 39 shows that stability condition parameters values versus frequency. These parameters are explained for conventional SSDA and optimized SSDA in section 4.1 and 4.2.

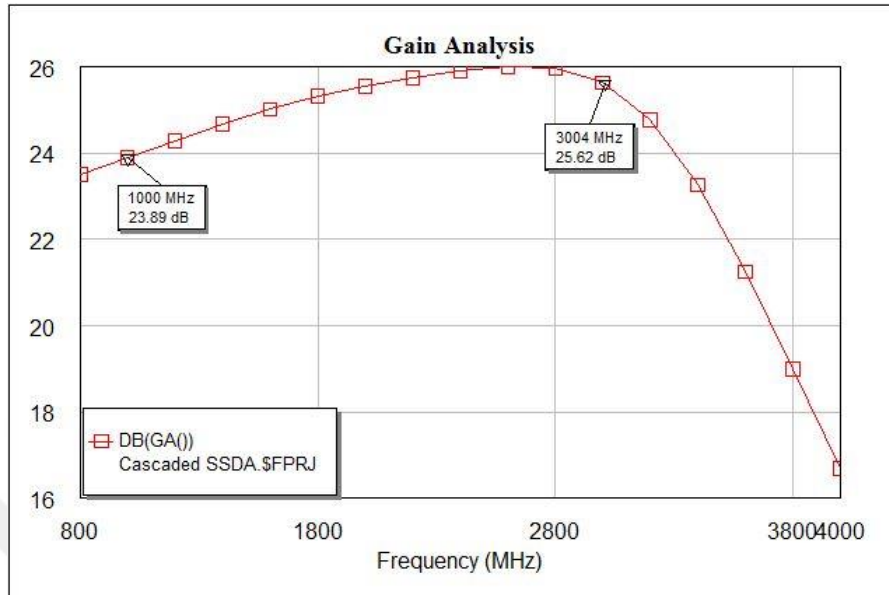

Figure 40 Gain performance of 2-Cascaded SSDA

As seen in Fig. 40, gain performance is better than conventional distributed amplifier. This design is based on conventional distributed amplifier concept and better results are obtained with low pass and bandpass structured cascaded distributed amplifier design. 2- Cascaded single stage distributed amplifier provides high gain in comparison with conventional SSDA. The minimum available gain is measured at the beginning of frequency band in other words near 1 GHz and gain is increased to 26 dB towards the end of frequency range.

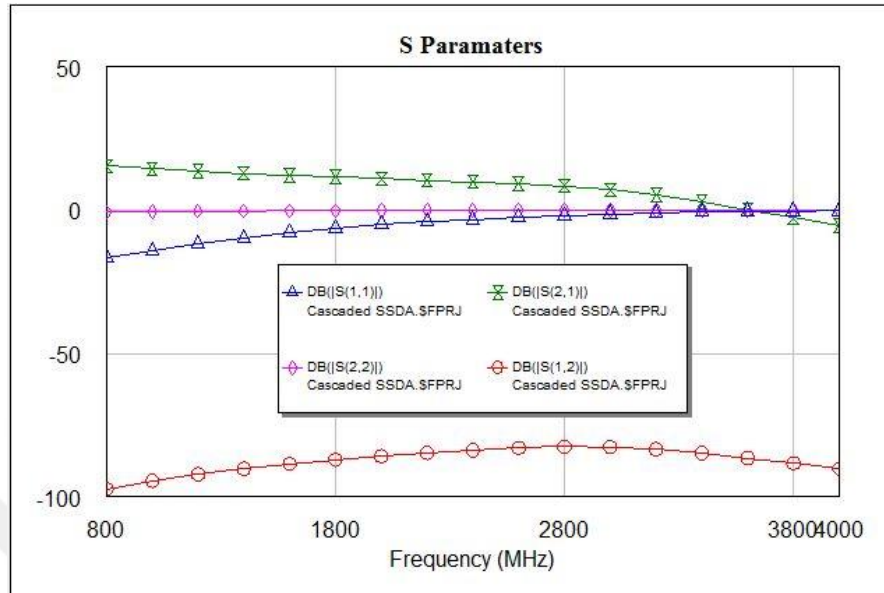

Figure 41 S Parameters of 2-Cascaded SSDA

S parameters represent electrical behavior of 2- Cascaded SSDA and their logarithmic magnitudes are shown in Fig. 41. As seen in Fig. 41, input return loss is approximately -14 dB at the beginning of band and increases almost -1.4 dB at the end of the band. Output return loss which starts from -0.5 dB and ends with -0.06 dB is like a line close 0 dB.

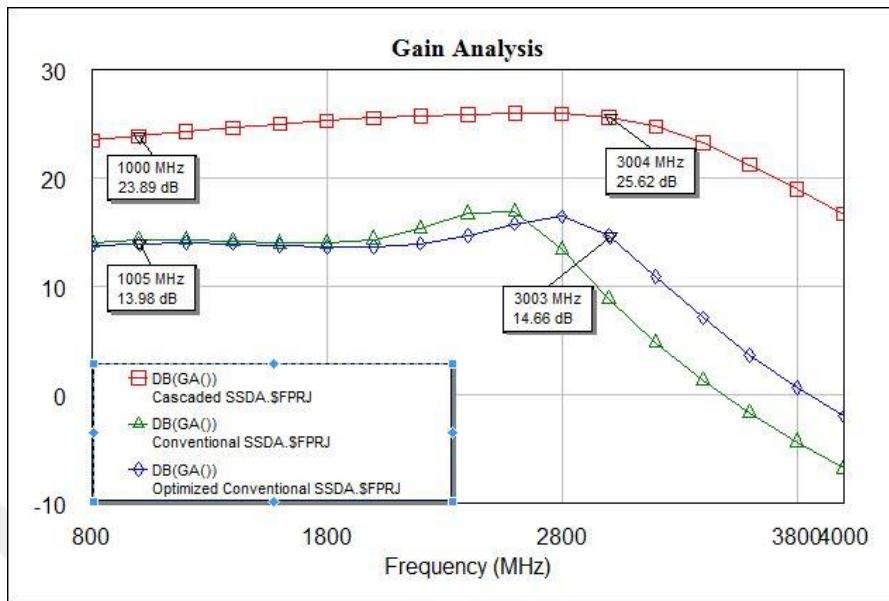

Figure 42 Gain analyses of 2-CSSDA and conventional SSDAs

.Fig. 42 shows gain analyses of all amplifier circuits studies in the thesis. Optimized SSSA provides covering flatness for selected whole frequency range after first SSSA design and 2-Cascaded SSSA achieves high flat gain in comparison with conventional configurations of distributed amplifiers in the thesis.

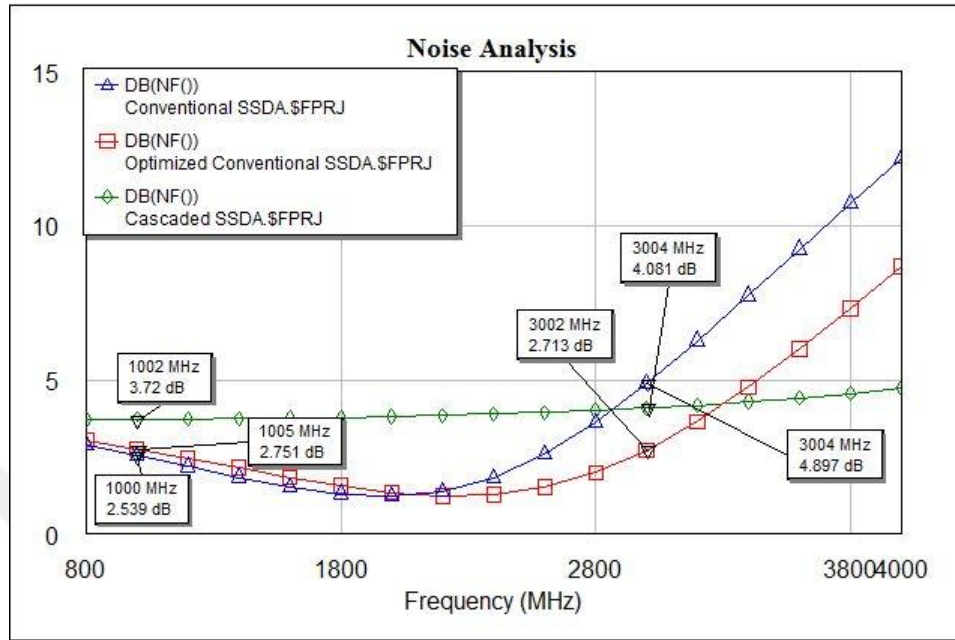

Figure 43 Noise figure comparison of conventional DAs and CSSDA

Fig. 43 represents noise figure of 2-CSSDA and conventional distributed amplifiers. In first designed distributed amplifier, noise figure is like a curve between almost 2.55 dB and 4.9 dB also the minimum noise figure is measured as 1.2 dB near 2 GHz. Other side, noise figure of optimized distributed amplifier is similar curve with first design yet noise figure is lower than 4.9 dB at the end of frequency range and it is approximately 2.7 dB. Optimization process can be accepted successful in terms of lower noise figure. Finally, noise figure 2-Cascaded distributed amplifier starts with 3.72 dB and goes to 4.08 dB.

In this chapter, conventional and cascaded single stage distributed amplifiers are designed, after circuits simulations results are evaluated. According to these evaluations, CSSDA has better specifications than conventional single stage distributed amplifier.

CHAPTER 5

CONCLUSION

In this thesis, classical microwave transistor amplifier main parameters, significant requirements are explained with their equations then they are followed design works of circuit schematics. Broadband amplifier topologies as compensating matching, balanced amplification and feedback amplification are discussed in brief. After that, distributed amplification is analyzed and designed with different point of view. Drawn circuit schematics of distributed amplifiers are simulated with AWR Microwave Office to obtain stability, s parameters, and gain, noise figure graphs. Studies in the thesis are limited with drawing circuit schematic of distributed amplifiers and simulations of these circuits according to stability, s parameters and gain, noise figure analyses. Therefore, theoretical procedures of distributed amplifier are followed and circuit schematics are designed with tuned values of circuit's components to obtain stability and gain flatness without implementations of distributed amplifier circuits.

First of all, conventional distributed amplifier is design at 1-3 GHz frequency range. According to, gate to source capacitance C_{gs} is 1.73 pF for ATF-54143. Cut off frequency is determined as 3 GHz by gate to source capacitance. Inductive artificial transmission lines are designed to absorb C_{gs} so that bandwidth is in increase. Simulation results show that single stage conventional distributed amplifier gain can be optimized. Before the optimization first design at 1-3 GHz, available gain is observed 14.27 dB and goes down approximately 8.8 dB at the end of frequency range. Interval of the bandwidth peak value is obtained as 16.8 dB at 2.5 GHz. Some lumped elements are arranged to match perfectly the transmission lines so gain performance is improved and band flatness slides to right (to high frequencies)

because of cut off frequency is changed to 3.2 GHz solve low gain performance at the end of frequency range (1-3 GHz). With conventional single stage distributed amplifier, noise figure is observed between 2.55 dB and 4.9 dB also the minimum noise figure is measured as 1.2 dB near 2 GHz.

After the optimization to obtain gain flatness at 1-3 GHz proposed distributed amplifier is designed according to 3.2 GHz cut off frequency. Lumped components of transmission lines are calculated to achieve flat gain performance. Hence, approximately 14+7 dB gain and at the beginning of frequency band 2.75 dB and at the end of the frequency band approximately 2.71 dB noise figure is measured with simulations. Minimum noise figure is observed approximately 1.23 dB near 2.2 GHz.

Moreover, impedance matching circuits also integrated to conventional single stage distributed amplifier and gain flatness is disappeared. Conjugate match technique does not cover whole bandwidth so better gain performance is not obtained in this configuration approach. However, T-type artificial transmission lines can provide low pass filtering towards the cut off frequency of the amplifier. Another way is designed transmission lines using bandpass filtering technique. This technique is not investigated in this thesis but design and analysis studies show that as a consequence.

In addition, an optimum stage of distributed amplifier is calculated and the result is found as 24 so after the first stage gain performance scales down. An optimum stage is determined according to characteristic of transistor and operation frequency. For this result, it is regarded a drawback for conventional distributed amplifier. Cascaded single stage distributed amplifier is studied to obtain high gain at broadband with arrange transmission lines terminated interstage characteristic impedance. From starting bandwidth, gain is almost 23.9 dB and towards to end of bandwidth gain is almost 25.62 dB. Peak value is almost 26 dB near 2.8 GHz. Noise figure

characterization is high in reference to conventional single stage distributed amplifier.

In conclusion, 2-CSSDA configuration with different termination techniques is preferred as a broadband amplifier design approach. In this study, this technique is more advantageous than conventional single stage distributed amplifier in terms of gain performance.

REFERENCES

1. **Liao S.Y., (1980)**, “*Microwave Devices and Circuits*”, Prentice Hall, New Jersey.
2. **Bahl I.J., (2009)**, “*Fundamentals of RF and Microwave Transistor Amplifiers*”, John Wiley, New Jersey.
3. **Gonzales G., (1984)**, “*Microwave Transistor Amplifier, Analysis and Design*”, Prentice Hall, New Jersey.
4. **Matthews E.W., (1955)**, “*The Use of Scattering Matrices in Microwave Circuits*”, IRE Transactions on Microwave Theory and Techniques. vol. 3, no. 3, pp.21-26.
5. **Obrzut J., (2013)**, “*General analysis of microwave network scattering parameters for characterization of thin film materials*”, Measurement. vol. 46, no. 8, pp. 2963-2970.
6. **Hunton J.K., (1960)**, “*Analysis of Microwave Measurement Techniques by means of signal flow graphs*”, IRE Transactions on Microwave Theory and Techniques. vol. 8, no.2, pp.206-212.
7. **Chung B.K., (2006)**, “*Variability analysis of impedance matching network*”, Microelectronics Journal. vol. 37, no. 11 ,pp. 1419-1423.
8. **Edwards M.L., (1992)**, “*A New Criterion for Linear 2-Port Stability Using a Single Geometrically Derived Parameter*”, IEEE Transactions on Microwave Theory and Techniques. Vol. 40, no.12, pp.2303-2311.

9. **Pozar D.M., (2012)**, *“Microwave Engineering”*, John Wiley & Sons.
10. Ayasli Y., Mozzi R.L. Vorhaus J.L., Reynolds L.D., Pucel R.A., (1982), *“A Monolithic GaAs 1-13-GHz Traveling-Wave Amplifier”*, IRE Transactions on Microwave Theory and Techniques. vol. 30, no. 7, pp.976-981.
11. **Benyamin B., Berwick M., (2000)**, *“The gain advantages of four cascaded single stage distributed amplifier configurations”*, 2000 IEEE MTT-S International Microwave Symposium Digest (Cat. No.00CH37017), vol. 3, pp.1325-1328.
12. **Virdee A.S., Virdee B.S., (1999)**, *“2-18 GHz ultra-broadband amplifier design using a cascaded reactively terminated single stage distributed concept”*, Electronic Letters. vol. 35, no. 24, pp.2122-2123.
13. **Niclas K.B., (1984)**, *“Reflective Match, Lossy Match, Feedback and Distributed Amplifiers: A Comparison of Multi-Octave Performance Characteristics”*, 1984 IEEE MTT-S International Microwave Digest. pp.215-217.
14. **Inoue Y., Sato M., Ohki T., Makiyama K., Takahashi T., Shigematsu H., Hirose T., (2005)**, *“A 90-GHz InP-HEMT Lossy Match Amplifier With a 20-dB Gain Using a Broadband Matching Technique”*, IEEE Journal of Solid-State Circuits. vol. 40. no. 10, pp.2098-2103.
15. **Virdee B.S, Virdee A.S., Banyamin B.Y., (2004)**, *“Broadband Microwave Amplifiers”*, Artech House, Boston.
16. **Niclas K.B., Wilser W.T., Gold R.B., Hitchens W.R., (1980)**, *“The Matched Feedback Amplifier: Ultrawide-Band Microwave Amplification with GaAs MESFET’s”*, IRE Transactions on Microwave Theory and Techniques. vol. MIT-28, no. 4, pp.285-294.
17. **Percival W.S., (1937)** *“Improvement in and Relating to Thermionic Valve Circuits”*, British Patent No 460562
18. **Ginzton E.L., Hewlett W.R., Jasberg J.H., Noe J.D., (1948)**, *“Distributed Amplification”*, IRE Proceedings. vol. 36. no. 8, pp. 956-969.
19. **Jutzi, W., (1969)**, *“A MESFET distributed amplifier with 2 GHz bandwidth”*, Proceedings of the IEEE. vol. 57. no. 6, pp.1995-1996.

20. **Benyamin B., Berwick M., (2000)**, “*Analysis of the Performance of Four-Cascaded Single-Stage Distributed Amplifiers*”, IEEE Transactions on Microwave Theory and Techniques. vol. 48, no. 12, pp.26657-26663.
21. **Paoloni C., D’Agostino S., (1995)**, “*An Approach to Distributed Amplifier Based on a Design-Oriented FET Model*”, IEEE Transactions on Microwave Theory and Techniques. vol. 43, no. 2, pp.272-277.
22. Avago Technologies ATF-54143 Low Noise Enhancement Mode Pseudomorphic HEMT Datasheet.
23. **Kumar N., Grebennikov A., (2015)**, “*Distributed Power Amplifiers for RF and Microwave Communications*”, Artech House. Boston.
24. **Virdee A.S., Virdee B.S., (2001)**, “*A novel high efficiency multioctave amplifier using cascaded reactively terminated single-stage distributed amplifiers for EW System Applications*”, 2001 IEEE MTT-S International Microwave Symposium Digest (Cat. No.01CH37157). vol. 1, pp.519-522.
25. **Sayginer M., Yazgi M., Kuntman H.H., Virdee B.S., (2011)**, “*1-8 GHz high efficiency single stage travelling wave power amplifier*”, 2011 7 th International Conference on Electrical and Electronics Engineering (ELECO). pp. II-85 - II-88.
26. **Virdee B.S, Virdee A.S., Banyamin B.Y., (2004)**, “*Bandwidth and Efficiency Improvements in Cascaded Single-Stage Distributed Amplifier*”, 2002 32 nd European Microwave Conference. pp. 1-4.
27. **Minnis B.J., (1994)**, “*The travelling wave matching technique for cascable MMIC Amplifiers*”, IEEE Transactions on Microwave Theory and Techniques. vol. 42, no. 4, pp.690-692.

APPENDIX A
DIE MODEL OF ATF-54143

ATF-54143 Die Model

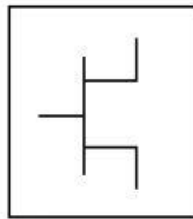

Advanced_Curtice2_Model

MESFETM1

NFET=yes

PFET=no

Vto=0.3

Beta=0.9

Lambda=82e-3

Alpha=13

Tau=

Tnom=16.85

Idstc=

Ucrit=-0.72

Vgexp=1.91

Gamds=1e-4

Vtotc=

Betatce=

Rgs=0.25 Ohm

Rf=

Gscap=2

Cgs=1.73 pF

Cgd=0.255 pF

Gdcap=2

Fc=0.65

Rgd=0.25 Ohm

Rd=1.0125 Ohm

Rg=1.0 Ohm

Rs=0.3375 Ohm

Ld=

Lg=0.18 nH

Ls=

Cds=0.27 pF

Rc=250 Ohm

Crf=0.1 F

Gsfwd=

Gsrev=

Gdfwd=

Gdrev=

R1=

R2=

Vbi=0.8

Vbr=

Vjr=

Is=

Ir=

Imax=

Xti=

Eg=

N=

Fnc=1 MHz

R=0.08

P=0.2

C=0.1

Taumdl=no

wVgfw=

wBvgs=

wBvgd=

wBvds=

wldsmax=

wPmax=

AllParams=

APPENDIX B

TOUCHSTONE FILE OF ATF-54143 FOR $V_{ds}=3V$, $I_{ds}=60mA$

```
!ATF-54143
!s-parameters at Vds=3V, Id=60mA. Last updated 17/05/01 AR.
# GHZ S MA R 50

.100 .989 -18.9 27.664 167.6 .009 80.0 .541 -14.0
.200 .944 -36.2 26.327 155.8 .017 71.3 .519 -27.2
.300 .914 -53.5 24.304 145.4 .024 63.8 .482 -38.9
.400 .875 -67.8 22.237 136.4 .029 57.8 .448 -49.1
.500 .809 -80.8 20.047 128.0 .033 52.4 .395 -58.8
.600 .778 -92.0 18.250 121.4 .036 48.7 .365 -66.1
.700 .748 -101.8 16.615 115.6 .039 45.7 .335 -73.3
.800 .723 -110.2 15.204 110.7 .041 43.6 .312 -79.0
.900 .706 -117.9 14.006 106.2 .043 41.8 .291 -83.8
1.000 .687 -124.4 12.940 102.2 .045 40.4 .272 -88.5
1.100 .675 -130.1 12.022 98.5 .047 39.5 .256 -92.4
1.200 .664 -136.0 11.218 95.1 .049 38.2 .242 -96.1
1.300 .655 -141.1 10.514 91.9 .050 37.4 .229 -99.5
1.400 .647 -145.5 9.903 88.9 .052 36.7 .218 -102.3
1.500 .640 -149.8 9.335 86.1 .053 36.1 .207 -105.2
1.600 .633 -154.1 8.841 83.4 .055 35.5 .198 -107.5
1.700 .629 -157.8 8.401 80.7 .057 35.0 .189 -110.3
1.800 .623 -161.4 8.005 78.2 .058 34.4 .180 -112.4
1.900 .621 -164.9 7.643 75.6 .060 33.8 .173 -114.7
2.000 .615 -168.3 7.308 73.3 .062 33.3 .165 -117.0
2.100 .611 -171.5 7.009 70.9 .063 32.7 .158 -119.3
2.200 .610 -175.0 6.748 68.5 .065 32.1 .151 -121.8
2.300 .607 -177.8 6.467 66.3 .067 31.5 .143 -124.4
2.400 .604 179.2 6.227 64.0 .068 30.8 .137 -126.7
2.500 .602 176.2 6.010 61.8 .070 30.1 .131 -129.7
2.600 .602 173.4 5.804 59.6 .072 29.4 .125 -132.1
2.700 .600 170.6 5.614 57.4 .073 28.7 .121 -135.3
```

2.800	.599	167.7	5.430	55.2	.075	27.9	.115	-138.6
2.900	.600	165.0	5.258	53.1	.076	27.2	.111	-142.3
3.000	.601	162.3	5.098	51.0	.078	26.5	.106	-146.5
3.100	.599	159.6	4.948	48.9	.080	25.6	.102	-150.4
3.200	.600	157.2	4.800	46.9	.081	24.8	.099	-154.9
3.300	.602	154.6	4.671	44.9	.083	24.1	.096	-159.6
3.400	.603	151.9	4.543	42.8	.085	23.1	.095	-164.4
3.500	.608	149.6	4.419	40.8	.086	22.2	.094	-170.1
3.600	.608	147.1	4.304	38.8	.088	21.3	.093	-175.4
3.700	.613	144.4	4.192	36.7	.090	20.2	.094	179.8
3.800	.617	141.9	4.089	34.8	.091	19.1	.094	174.5
3.900	.618	139.5	3.989	32.8	.093	18.1	.096	170.1
4.000	.621	137.1	3.896	30.8	.094	17.1	.099	165.2
4.100	.624	135.1	3.799	28.9	.095	16.1	.102	160.6
4.200	.627	132.9	3.712	27.0	.097	15.1	.106	156.5
4.300	.633	130.6	3.628	25.0	.098	14.1	.110	152.5
4.400	.637	128.3	3.545	23.1	.099	13.2	.115	149.2
4.500	.642	126.1	3.466	21.2	.101	12.1	.119	145.4
4.600	.645	123.6	3.392	19.2	.102	11.0	.124	142.6
4.700	.650	121.2	3.319	17.3	.103	9.9	.129	139.6
4.800	.652	119.6	3.250	15.4	.105	8.9	.134	136.5
4.900	.652	117.4	3.181	13.5	.106	7.9	.138	134.4
5.000	.656	115.5	3.114	11.7	.107	6.8	.142	131.5
5.100	.659	113.9	3.049	10.0	.108	5.8	.146	129.3
5.200	.663	112.1	2.988	8.1	.109	4.9	.150	127.1
5.300	.668	110.2	2.927	6.3	.111	3.9	.153	125.2
5.400	.673	108.2	2.871	4.5	.112	2.8	.157	123.6
5.500	.673	106.2	2.818	2.7	.113	1.7	.161	122.0
5.600	.678	103.7	2.766	.7	.114	.5	.164	120.4
5.700	.680	102.1	2.712	-1.0	.115	-.6	.168	118.6
5.800	.677	100.7	2.665	-2.7	.116	-1.5	.171	116.7
5.900	.681	99.0	2.617	-4.4	.118	-2.6	.173	115.2
6.000	.685	97.2	2.577	-6.4	.119	-3.9	.175	112.4